



SHOP DRAWING REVIEW

Project Name: Victoria Park Arena

Project No. CA-WSP-221-05263-00

Date 2025-02-11

Received:

Shop Drawing: Title: Dampers, GRDs, VAV
Revision: 00
Submission No.: 21-01

This review by consultant is for sole purpose of ascertaining conformance with general design concept. This review does not mean that consultant approves detail design inherent in shop drawings, responsibility for which remains with contractor, and such review does not relieve contractor of responsibility for errors or omissions in shop drawings or of contractor’s responsibility for meeting all requirements of contract documents. Be responsible for dimensions to be confirmed and correlated at job site, for information that pertains solely to fabrication process or to techniques of construction and installation, and for coordination of the work of subtrades.

<input type="checkbox"/> Reviewed	Mechanical Review Required <input checked="" type="checkbox"/>	Electrical Review Required <input checked="" type="checkbox"/>
<input type="checkbox"/> Reviewed as Noted	Reviewed by: Jerry Nweisser	Reviewed by: Brad Li
<input checked="" type="checkbox"/> Revise & Resubmit	Review Date: 2025-02-11	Review Date: 2025-02-11
Item	Comments	
1.	Consult Mechanical submittal displays the wrong project name. please update to correct.	
2.	Contractor to confirm with architect the colour and finish of all diffusers.	
3.	Contractor to ensure that diffuser adapter are of the same material as the diffusers.	
4.	There are multiple references requiring the mechanical contractor to confirm the mounting of mechanical equipment, counterbalance arrangements, and other related details. The mechanical contractor is to highlight their selections accordingly.	
	Elec review comments below (review as noted):	
5	Install the combined fire and smoke dampers by connecting to the smoke detectors as per relevant codes and standards requirements, with the sequence of operation to be set up and programmed by coordination with damper manufacturer and fire alarm system manufacturer. Provide additional associated materials and devices as needed to suit the installation and requirements.	

End of Review

<input type="checkbox"/> REVIEWED	BY Jerry Nweisser
<input type="checkbox"/> REVIEWED AS NOTED	DIVISION Buildings - Sustainability
<input checked="" type="checkbox"/> REVISE & RESUBMIT	DATE 2/11/2025
	SUBMITTAL# 21-01
	PROJECT CA-WSP-221-05263-00
<p>THE REVIEW OF THIS DRAWING DOES NOT IN ANY WAY RELIEVE THE VENDOR OR CONTRACTOR OF RESPONSIBILITY FOR ITS ACCURACY OR FOR COMPLIANCE WITH THE CONTRACT DOCUMENTS.</p>	

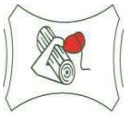

RAFAT

8850 GEORGE BOLTON PARKWAY, CALEDON, ONTARIO L7E 2Y4

Shop Drawings Transmittal No:	23 30 00-01R0
--	---------------

Project Name:	Construction of Victoria Park Arena and Brampton Sports Hall of Fame	Project No.	NRFP2024-232
		DATE:	30 Jan 2025
		Submittal Required Return Date:	13 Feb 2025
Submittal No:	21		

Title:	SD-Dampers, GRDs, VAV
---------------	-----------------------

To:	Mark Falkenburger
------------	-------------------

Checked by:	Abdullah Hissamuddin	To Be Reviewed By the Following Consultants	Architecture49 & WSP
--------------------	-----------------------------	--	----------------------

Submitted for:	Review and Approval
-----------------------	---------------------

Consultants Response	
-----------------------------	--



SUBMITTAL REVIEW
 For general compliance with the design concept and contract documents. Subcontractor is solely responsible for jobsite correlation and correctness of all ratings, sizings, type, style, dimensions, finish, quantities and satisfactory fitting to other work and equipment. This review does not change the intent of the contract document.



54 Audia Court, Unit 2
Concord, ON L4K 3N5
(905)-738-1400

Submittal 24-280-004

PROJECT NAME	PROJECT ADDRESS	DATE SUBMITTED
VICTORIA PARK ARENA	24-280 20 Victoria Crescent, Brampton, ON L6T 1E4	Feb 4, 2025

TO	FROM
Abdullah Hissamuddin	INZAMAN KHAN
COMPANY	COMPANY
RAFAT GENERAL CONTRACTOR INC.	Consult Mechanical Inc.
EMAIL	EMAIL
abdullah.hissam@rafat.ca	inzaman@consultmechanical.com
ADDRESS	ADDRESS
8850 GEORGE BOLTON PKWY BOLTON, ON L7E 2Y4	54 Audia Court, Unit 2 Concord, ON L4K 3N5

Title

GRDs (23 30 00), Dampers(23 30 00) & VAVs(23 36 00)

Description

Tags: BDD / CFSD / FD / GRD / LV / MD / VAV

Package Items

SPEC	SUBSECTION	ITEM	TYPE
------	------------	------	------



Submittal # 85090

APPROVAL REQUIRED

Project 22104386-MECH-1- Brampton Victoria Park Arena
Leader Nevin Wong
Job Site Brampton Victoria Park Arena
Submission Date 2025-01-29
Sold To CONSULT MECH
Submitted By Lindsay Grahame

Contacts

Role	Customer	Contact	Our Rep
General Contractor	Rafat General Contracing Inc		
Mechanical Contractor	Con-Sult Mechanical Inc.*	Mohammed Ali Khan Lodhi	Nevin Wong
Mechanical Contractor	Con-Sult Mechanical Inc.*	Paul Leddy	Nevin Wong
Designer	WSP MMM Group		Alex Forsea

Deliverables

Track #	289036		
Tag	A, B, C, D, E, F, G		
Description	Grds		
Manufacturer	Metalaire		
Production Lead Time	6 - 8 weeks		
Revision #	0		

Notes:

Contractor to confirm size, quantities, and mounting type prior to ordering.

Lead times are estimated and subject to change on short notice

Attention:

- 1) HTS will provide equipment in accordance with the attached shop drawings.
- 2) Upon approved submittal and customer release, HTS will release equipment to fabrication per the published lead times. Any storage fees associated with project schedule changes will be the responsibility of the purchaser.
- 3) HTS can provide freight and logistics to the purchaser as an added benefit of doing business with HTS. When freight is received by the purchaser, any noticeable damage must be recorded. Otherwise, HTS is not responsible for subsequent damage claims.

Approval Stamps

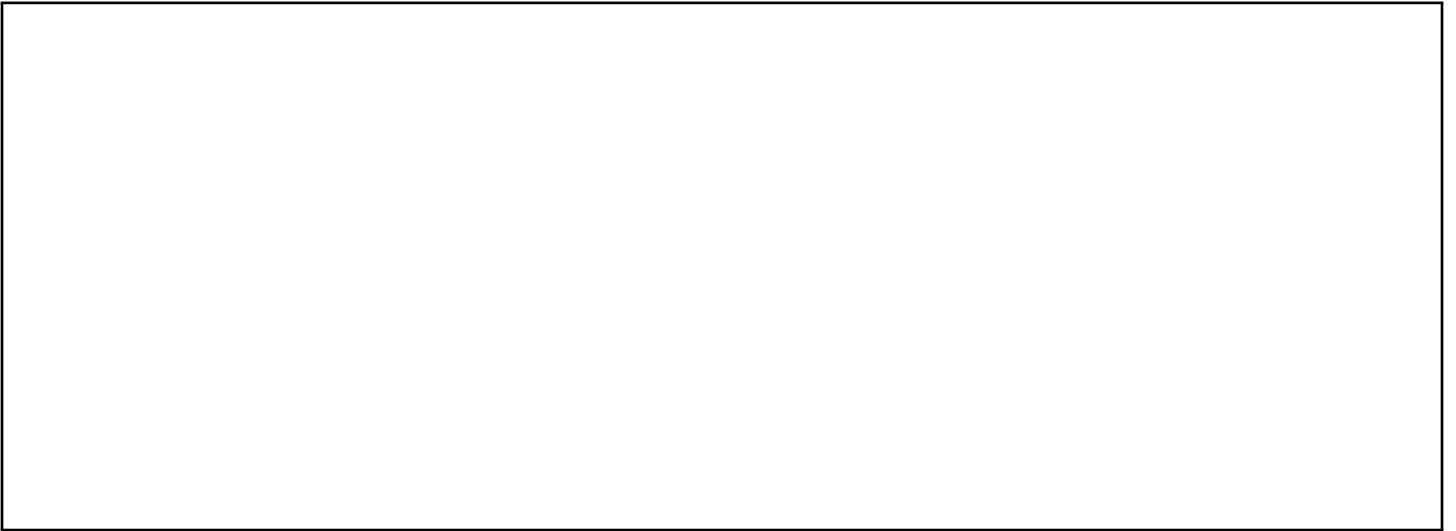
A large, empty rectangular box with a thin black border, intended for placing approval stamps. The box is currently blank.

Specifications & Schedule

2.29 GRILLES AND DIFFUSERS

- .1 Grilles and diffusers of type, size, capacity, finish, and arrangement as shown on drawings and in accordance with drawing schedule, each equipped with all required mounting and connection accessories to suit mounting location and application.

GRILLES AND DIFFUSER SCHEDULE									
UNIT TAG	BASIS OF DESIGN				TYPE	VOLUME CONTROL	MATERIAL	FINISH	APPLICATION
	MANUFACTURER	MODEL	INLET SIZE (mm)	SIZE (mm x mm)					
A	PRICE	SPD	REFER TO FLOOR PLAN	600 x 600	CEILING SUPPLY DIFFUSER	YES	STEEL	MATCH ARCH.	
B	PRICE	510	REFER TO FLOOR PLAN		LOUVERED SUPPLY GRILLE - DOUBLE DEFFLECTION	YES	STEEL	MATCH ARCH.	
C	PRICE	635	REFER TO FLOOR PLAN		LOUVERED RETURN/EXHAUST GRILLE	YES	ALUMINIUM	MATCH ARCH.	
D	PRICE	RCDA	REFER TO FLOOR PLAN		ROUND CONE DIFFUSER - FULLY ADJUSTABLE	YES	STEEL	MATCH ARCH.	
E	PRICE	96	REFER TO FLOOR PLAN		HEAVY DUTY RETURN GRILLE	-	STEEL	MATCH ARCH.	
F	PRICE	ATGH	REFER TO FLOOR PLAN		HEAVY DUTY SIGHT-PROOF DOOR GRILLE	-	ALUMINIUM	MATCH ARCH.	TO BE WITH FIRE DAMPER WHERE INDICATED ON DRAWING
G	PRICE	CF	1" TWO SLOTS, 8" INLET, 60" LENGTH		SUPPLY SLOT DIFFUSER C/W ENGINEERED PLENUM BOX	YES	ALUMINIUM	MATCH ARCH.	TO BE COORDINATED WITH CEILING SUPPLIER

GENERAL NOTES:

- All diffusers and grilles shall suit the ceiling construction, coordinate with architectural ceiling plan. diffusers in drywall ceiling to be c/w adaptor frame to accommodate installation, diffuser adaptor frame shall be of the same material as the diffuser.
- All dampers shall be of the same material as the diffuser or grille unless otherwise noted.
- Grille and diffuser colour to be approved by architect. where diffuser plenums are exposed, contractor to paint plenum to suit architect;

Grilles

Registers

Diffusers

METALAIRE

Submittal: 5750 Square Ceiling Diffusers Square Plaque Face Diffuser

Model:

5750-6 Square Plaque Face Diffuser - Round Neck - T-Bar Lay-In

Please see plaster frame drawing for surface mount application.

Note: For surface mount installations use of plaster frame is recommended

5750-6 - T-Bar Lay-In

Face View

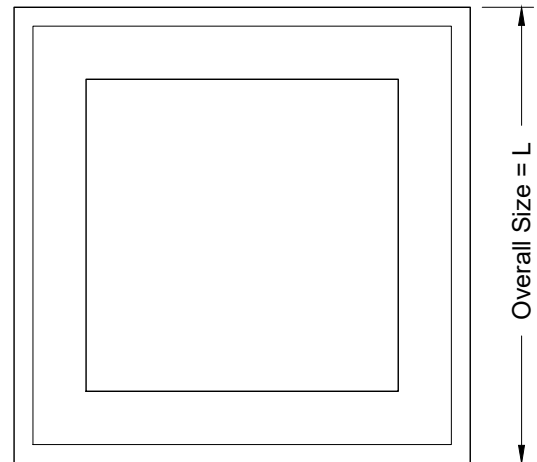
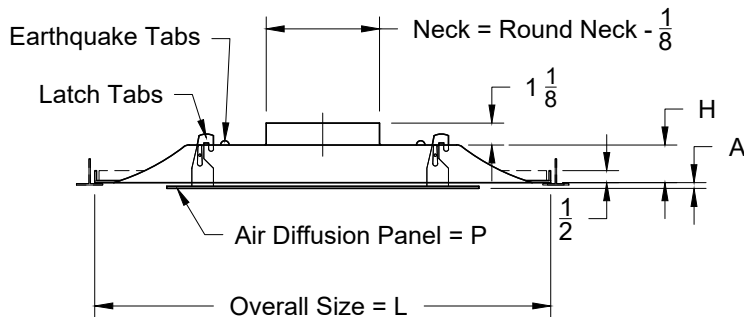

12X12 Face

Module Size	L	P	H	A
24 x 24	23 3/4	18 x 18	2 1/2	1/8
12 x 12	11 5/8	9 x 9	1	1/2

1. Available Finishes

Standard Finish:
01 White

2. Available Accessories

- RSD - Radial Shutter Damper
- TBPF - T-Bar Plaster Frame

3. Available Options

4. Construction Details

- Available Sizes Only as Listed
- Available Neck Sizes as Listed: 6, 8, 10, 12, 14 and 15
- Materials: Available in Steel, Aluminum and Aluminized Steel
- Consult Software for Available Border Types

All Dimensions $\pm 1/16"$

METALAIRE

Submittal: TBPf GRD Accessories T-Bar Plaster Frame, Aluminum

Model: **TBPf** T-Bar Plaster Frame

TBPf - T-Bar Lay-In

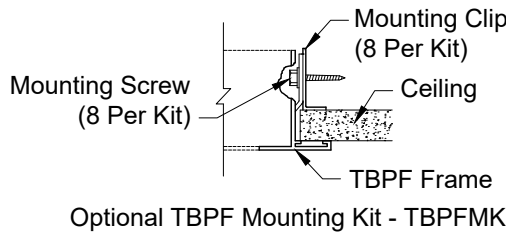
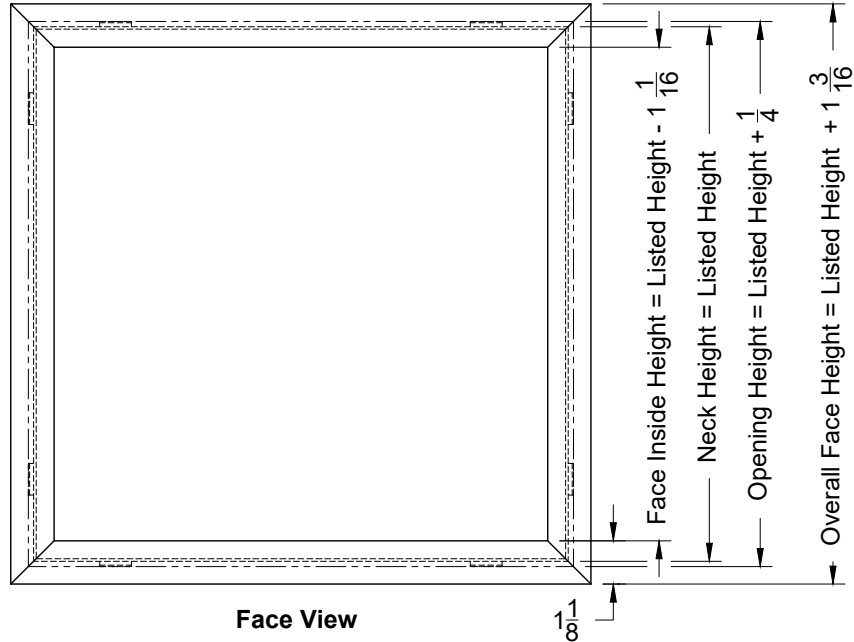
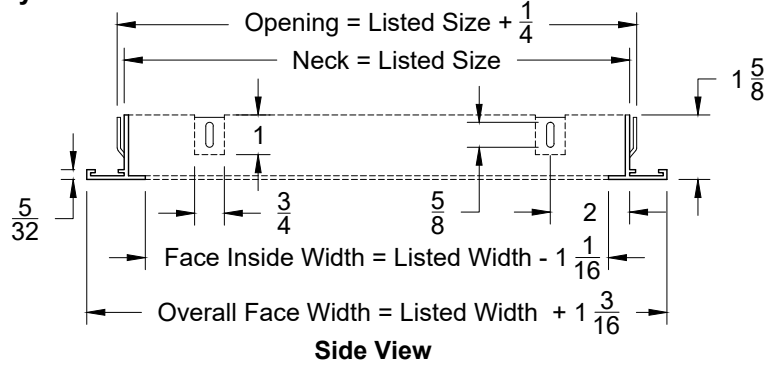

Listed Size
12 x 12
24 x 12
20 x 20
24 x 24
36 x 24
36 x 36
48 x 24
48 x 48

1. Available Finishes	2. Available Accessories	3. Available Options	4. Construction Details
Standard Finish: 01 White			<ul style="list-style-type: none"> Aluminum Construction Only Available in Listed Sizes

All Dimensions $\pm 1/16"$

SERIES 5750 PERFORMANCE DATA MODEL 5750

Listed Size	Neck Size	fpm Vn	400	500	600	700	800	900	1000	1200	1400	1600
		Pv	0.01	0.016	0.022	0.031	0.04	0.05	0.062	0.09	0.122	0.249
12 x 12	6	CFM	80	100	120	135	155	175	195	235	275	315
		Ps	.009	.014	.021	.024	.032	.041	.051	.075	.104	.137
		Pt	.019	.030	.043	.054	.072	.092	.114	.165	.226	.297
		Throw*	3-4-7	3-5-7	4-6-8	4-6-9	5-6-9	6-7-10	6-7-10	6-8-11	7-9-12	8-9-13
		Throw	3-4-7	4-5-7	4-6-8	5-6-9	5-7-9	6-7-10	6-7-10	7-8-11	7-9-12	8-9-13
		NC	<15	<15	<15	16	18	21	23	27	31	34
	8	CFM	140	175	210	245	280	315	350	420	490	560
		Ps	.017	.027	.039	.053	.069	.087	.108	.155	.212	.276
		Pt	.027	.043	.061	.083	.109	.138	.170	.245	.334	.436
		Throw*	3-5-9	4-7-10	5-8-11	6-8-11	7-9-12	8-9-13	8-10-14	9-11-15	9-11-16	10-12-17
		Throw	4-6-9	5-7-10	6-8-11	7-8-12	7-9-13	8-9-13	8-10-14	9-11-15	10-12-17	10-13-18
		NC	<15	<15	17	20	22	25	27	31	34	37
24 x 24	6	CFM	80	100	120	135	155	175	195	235	275	315
		Ps	.003	.004	.006	.006	.008	.011	.014	.021	.029	.039
		Pt	.013	.020	.029	.036	.048	.061	.076	.110	.151	.198
		Throw*	0-1-4	1-2-6	1-2-7	1-3-8	2-4-8	2-5-9	3-5-9	4-7-10	5-8-11	6-9-12
		Throw	1-2-5	1-3-6	2-4-7	2-4-8	3-5-9	4-5-9	4-6-10	5-7-11	6-8-12	6-9-13
		NC	<15	<15	<15	<15	15	18	21	26	31	35
	8	CFM	140	175	210	245	280	315	350	420	490	560
		Ps	.007	.012	.017	.023	.030	.038	.047	.067	.091	.119
		Pt	.017	.027	.039	.053	.070	.088	.109	.157	.213	.279
		Throw*	1-1-6	1-2-7	1-3-9	2-4-10	3-6-11	3-7-12	4-7-13	6-9-14	7-10-15	8-11-16
		Throw	1-2-6	2-4-8	2-5-10	3-6-11	4-6-12	5-7-13	5-8-13	6-10-14	7-11-16	9-12-17
		NC	<15	<15	<15	17	21	25	28	34	39	42
	10	CFM	220	275	325	380	435	490	545	655	765	875
		Ps	.016	.025	.034	.047	.061	.078	.096	.139	.190	.249
		Pt	.026	.040	.056	.077	.101	.128	.159	.229	.313	.409
		Throw*	1-2-7	1-3-9	2-4-11	2-5-13	3-7-14	4-8-15	5-9-16	7-11-17	9-13-19	10-14-20
		Throw	1-3-8	2-5-10	3-6-12	4-7-14	5-8-15	6-9-16	7-10-17	8-12-18	9-14-20	11-15-21
		NC	<15	15	15	21	26	30	33	37	41	43

SERIES 5750 PERFORMANCE DATA MODEL 5750

Listed Size	Neck Size	fpm Vn	400	500	600	700	800	900	1000	1200	1400	1600
		Pv	0.01	0.016	0.022	0.031	0.04	0.05	0.062	0.09	0.122	0.249
24 x 24	12	CFM	315	395	470	550	630	705	785	940	1100	1255
		Ps	.027	.042	.059	.081	.107	.133	.165	.236	.324	.422
		Pt	.037	.058	.082	.112	.146	.183	.227	.326	.446	.581
		Throw*	1-2-9	1-3-11	2-5-13	3-7-15	4-9-17	5-10-18	6-11-19	8-13-21	10-15-23	12-17-24
		Throw	2-4-10	2-6-12	4-7-14	5-8-17	6-10-18	7-11-19	8-12-20	10-14-22	11-17-23	13-18-25
		NC	<15	<15	17	22	27	30	33	38	42	45
	14	CFM	430	535	640	750	855	960	1070	1285	1495	1710
		Ps	.031	.049	.069	.095	.124	.156	.194	.280	.378	.495
		Pt	.041	.064	.092	.126	.164	.206	.256	.370	.501	.655
		Throw*	1-3-10	2-4-13	2-6-15	3-8-18	4-10-20	6-12-21	7-13-22	10-15-24	12-18-26	14-20-28
		Throw	2-4-11	3-6-14	4-8-17	6-10-19	7-11-21	8-13-22	9-14-23	11-17-25	13-19-27	15-21-29
		NC	<15	<15	20	25	30	33	36	40	43	46
	15	CFM	490	615	735	860	980	1105	1225	1475	1720	1965
		Ps	.038	.060	.086	.117	.152	.194	.238	.345	.469	.613
		Pt	.048	.076	.108	.148	.192	.244	.300	.435	.592	.772
		Throw*	1-3-11	2-4-14	3-6-16	4-8-19	5-11-21	6-12-23	7-14-24	11-17-26	13-19-28	15-21-30
		Throw	2-4-12	3-7-15	4-9-18	6-10-21	8-12-22	9-13-24	10-15-25	12-18-27	14-21-29	16-22-31
		NC	<15	<15	20	27	32	35	37	41	44	47

PERFORMANCE NOTES FOR SERIES 5750

All data is tested in accordance with ANSI/ASHRAE 70-2006.

DEFINITION OF UNITS

CFM Cubic Feet per Minute (air)

fpm Velocity of air stream in Feet per Minute

Pv Velocity pressure (inches of water column)

Pt Total pressure (inches of water column)

Ps Static pressure = Pt-Pv (inches of water column)

Throw* Non-isothermal horizontal throw (supply air temperature 15°F colder than average room temperature); values are for 150, 100 and 50fpm velocities

Throw Isothermal throw (supply air temperature the same as average room temperature); values are for 150, 100 and 50fpm velocities

NC Noise criterion, sound pressure level NC ratings are based on sound power level (Lw) re: 10⁻¹² watts minus a 10dB room attenuation in all octave bands

Vn Neck Velocity

METALAIRE

Submittal: H4004S

Supply Grille
Double Deflection, Steel

Model: **H4004S-1** Horizontal Front Blades - Flush Surface Mount

H4004S-1 - Flush Surface Mount

Face View

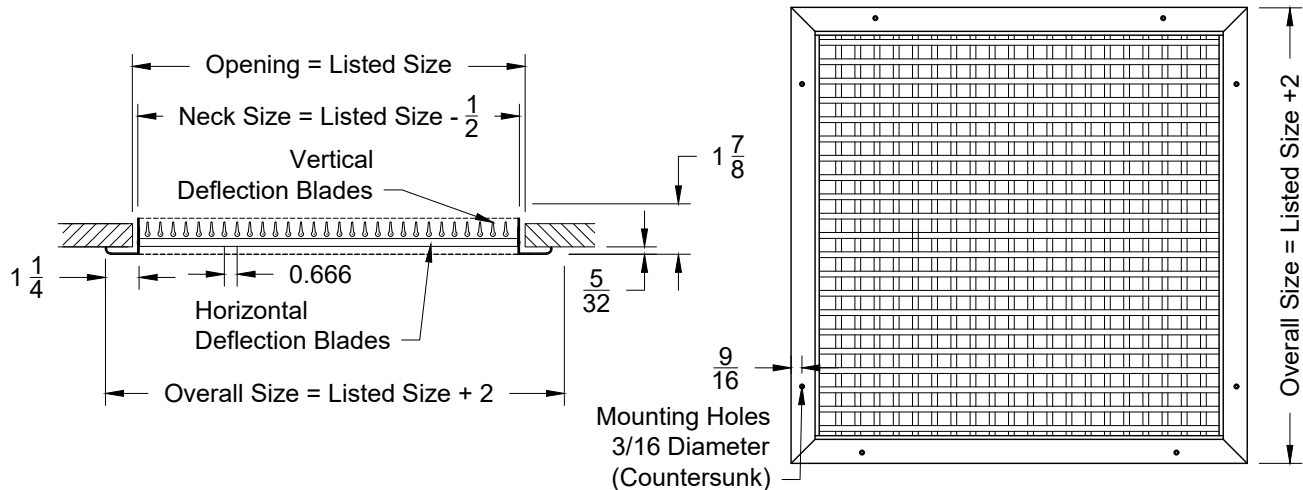

Note: This product complies with NFPA 90A-18 standard 4.3.7.3.2 and 4.3.8.3.2 and is constructed with openings through which a 1/2" sphere can not pass.

1. Available Finishes	2. Available Accessories	3. Available Options	4. Construction Details
Standard Finish: 01 White	OBD - Steel Opposed Blade Damper		<ul style="list-style-type: none"> • Odd/Fractional Sizes Available • Oversized Units made in multiple sections • Largest single section is 48x48 • Mullion strips provided for joining units in field
			All Dimensions ±1/16"

SERIES 4000 PERFORMANCE DATA

MODELS H/V4002, H/V4004, H/V4002M, H/V4002S, H/V4004S, H/V4002SM

Size		Nk Vel	200	300	400	500	600	700	800	1000
		Pt	.007	.015	.027	.042	.061	.083	.108	.169
06x04	Ac ft ²	CFM	24	36	48	60	72	84	96	120
	0.17	NC	-	-	-	-	-	-	11	18
	Throw		2-4-8	4-6-11	5-8-13	7-10-14	8-11-16	9-12-17	10-13-18	12-14-20
06x06	Ac ft ²	CFM	38	57	76	95	114	133	152	190
	0.25	NC	-	-	-	-	-	10	13	20
	Throw		4-8-17	7-12-21	10-15-24	12-17-26	14-20-28	15-21-30	17-23-32	19-24-34
08x08 10x06 12x05	Ac ft ²	CFM	73	110	146	183	219	256	292	365
	0.42	NC	-	-	-	-	11	13	16	22
	Throw		3-6-14	6-10-19	9-14-22	11-17-25	14-19-27	16-21-29	18-22-31	20-25-35
12x06	Ac ft ²	CFM	82	123	164	205	246	287	328	410
	0.50	NC	-	-	-	11	11	13	16	23
	Throw		3-7-15	7-11-20	10-15-24	12-18-26	15-20-29	17-22-31	19-24-33	21-26-37
10x08 14x6	Ac ft ²	CFM	93	140	186	233	279	326	372	465
	0.56	NC	-	-	-	10	12	14	17	23
	Throw		3-7-16	7-12-22	10-16-25	13-19-28	16-22-31	18-23-33	20-25-35	23-28-40
10x10 12x08 16x06	Ac ft ²	CFM	118	172	238	297	357	414	478	592
	0.69	NC	-	-	-	11	13	15	18	24
	Throw		4-8-18	8-13-25	12-18-28	15-22-32	18-25-35	20-27-37	23-28-40	26-32-45
14x08 18x06	Ac ft ²	CFM	134	201	267	335	394	468	534	661
	0.67	NC	-	-	-	11	13	15	18	25
	Throw		4-9-19	9-14-26	13-20-30	16-23-34	19-26-37	23-29-41	25-30-42	27-34-47
12x10 20x06	Ac ft ²	CFM	145	218	290	363	435	509	582	729
	0.83	NC	-	-	10	11	13	16	18	25
	Throw		4-9-19	9-15-27	13-19-31	16-24-35	19-27-38	23-29-41	26-31-44	29-35-49
16x08 22x06	Ac ft ²	CFM	153	230	306	383	459	536	612	765
	0.89	NC	-	-	10	12	14	16	19	25
	Throw		4-9-20	9-15-28	13-20-32	17-25-36	20-28-39	23-30-43	26-32-46	29-36-51
14x10 28x05	Ac ft ²	CFM	170	255	340	425	510	595	680	850
	0.85	NC	-	-	10	12	14	16	19	26
	Throw		4-10-21	10-16-29	14-21-34	18-26-38	21-29-42	25-32-45	28-34-48	31-38-54
12x12 24x06 18x08	Ac ft ²	CFM	176	263	351	439	527	615	701	878
	0.88	NC	-	-	10	12	14	16	19	26
	Throw		8-19-38	14-25-46	21-31-51	25-37-56	29-43-60	33-46-64	37-48-68	41-51-72
30x06 18x10	Ac ft ²	CFM	213	320	426	533	640	746	853	1066
	1.07	NC	-	10	11	13	15	17	20	27
	Throw		5-11-24	11-18-33	16-24-38	20-29-42	24-33-46	27-36-50	31-38-54	35-42-60

CONTINUED

SERIES 4000 PERFORMANCE DATA

MODELS H/V4002, H/V4004, H/V4002M, H/V4002S, H/V4004S, H/V4002SM

Size		Nk Vel	200	300	400	500	600	700	800	1000
		Pt	.007	.015	.027	.042	.061	.083	.108	.169
14x14	Ac ft ²	CFM	244	366	488	610	732	853	975	1219
	1.22	NC	-	10	12	13	15	18	21	27
	Throw		5-12-25	12-19-35	17-25-41	21-31-45	25-35-50	29-38-54	33-41-57	37-45-64
36x06 18x12	Ac ft ²	CFM	257	366	514	643	771	900	1028	1285
	1.29	NC	10	11	12	14	16	18	21	28
	Throw		5-12-26	12-19-36	17-26-42	22-32-47	26-36-51	30-39-55	34-42-59	38-47-66
22x10	Ac ft ²	CFM	273	410	546	683	819	956	1092	1385
	1.37	NC	10	11	12	14	16	18	21	28
	Throw		6-12-27	12-20-37	18-27-43	22-33-48	27-37-53	31-40-57	35-43-61	39-48-68
30x08 24x10	Ac ft ²	CFM	295	442	589	736	884	1031	1178	1472
	1.48	NC	10	11	13	14	16	19	21	28
	Throw		6-13-28	13-21-39	18-28-45	23-35-50	28-39-55	32-42-59	36-45-63	41-50-71
16x16	Ac ft ²	CFM	323	485	646	808	969	1131	1292	1615
	1.62	NC	11	12	13	15	17	19	22	28
	Throw		6-14-29	14-22-40	19-29-47	24-36-52	29-40-57	34-44-62	38-47-66	43-52-74

PERFORMANCE NOTES FOR SERIES 4000

All data is tested in accordance with ANSI/ASHRAE 70-2006.

DEFINITION OF UNITS

CFM Air volume is cubic feet per minute

Nk Vel Neck Velocity is the airstream velocity in the duct just before it reaches the supply outlet; measured in feet per minute

fpm Velocity of air stream in Feet per Minute

Throw Throw distance in feet are for terminal velocities of 150 fpm, 100 fpm and 50 fpm respectively

NC Noise criterion, sound pressure level NC ratings are based on sound power level (Lw) re: 10⁻¹² watts minus a 10dB room attenuation in all octave bands

Pt Total pressures in inches of water

Ac Actual Core Free Area in square feet

SERIES 4000 PERFORMANCE DATA

MODELS H/V4002, H/V4004, H/V4002M, H/V4002S, H/V4004S, H/V4002SM

Size		Nk Vel	200	300	400	500	600	700	800	1000
		Pt	.007	.015	.027	.042	.061	.083	.108	.169
24x12 36x08 48x06	Ac ft ²	CFM	364	546	727	909	1090	1272	1453	1816
	1.82	NC	11	12	13	15	17	20	22	29
	Throw			6-13-30	14-23-43	20-31-50	26-38-55	31-43-61	36-46-66	40-50-70
18x18	Ac ft ²	CFM	414	621	87	1034	1240	1447	1653	2066
	2.07	NC	12	13	14	16	18	20	23	29
	Throw			7-15-33	15-25-46	22-33-53	27-41-59	33-46-65	38-49-70	43-53-75
30x12 36x10	Ac ft ²	CFM	456	685	914	1142	1371	1600	1829	2386
	2.28	NC	12	13	14	16	18	20	23	30
	Throw			7-16-34	16-26-48	23-34-56	29-43-62	34-48-68	40-52-74	45-56-79
20x20	Ac ft ²	CFM	515	772	1030	1287	1545	1802	2059	2574
	2.59	NC	13	14	15	17	19	21	24	30
	Throw			8-17-37	17-27-51	24-37-59	30-46-66	37-51-72	43-55-78	48-59-83
24x18 36x12	Ac ft ²	CFM	550	826	1101	1377	1653	1928	2204	2755
	2.75	NC	13	14	15	17	19	21	24	31
	Throw			8-18-38	18-28-53	25-38-61	32-47-68	38-53-75	44-57-81	50-61-86
22x22 24x20 48x10	Ac ft ²	CFM	626	940	1254	1567	1881	2195	2509	3136
	3.13	NC	13	14	16	17	19	22	25	31
	Throw			8-19-40	19-30-56	27-40-65	34-50-73	40-56-80	47-61-86	53-65-92
24x24 36x16 48x12	Ac ft ²	CFM	750	116	1501	1877	2252	2628	3003	3754
	3.75	NC	14	15	16	18	20	23	25	32
	Throw			9-21-44	21-33-62	29-44-71	37-55-80	44-62-87	52-67-94	58-71-101
30x24 36x20	Ac ft ²	CFM	946	1297	1848	1999	2350	2701	3052	3754
	4.73	NC	15	16	17	19	21	23	26	33
	Throw			10-23-50	19-34-66	29-43-75	35-52-82	41-62-89	47-68-96	53-72-102
28x28	Ac ft ²	CFM	1030	1546	2061	2577	3093	3608	4124	5155
	5.15	NC	16	17	18	19	21	24	27	33
	Throw			11-24-52	24-39-72	34-52-83	43-65-93	52-72-102	60-78-110	68-83-118
36x24 48x18	Ac ft ²	CFM	1140	1709	2278	2846	3415	3984	4553	5690
	5.70	NC	16	17	18	20	22	24	27	34
	Throw			11-25-54	25-41-76	36-54-88	45-68-98	54-76-107	63-82-116	72-88-124
30x30	Ac ft ²	CFM	1190	1784	2378	2971	3565	4159	4753	5940
	5.95	NC	16	17	18	20	22	24	27	34
	Throw			12-26-56	26-42-78	37-56-90	46-69-100	56-78-110	65-84-119	73-90-127

CONTINUED

SERIES 4000 PERFORMANCE DATA

MODELS H/V4002, H/V4004, H/V4002M, H/V4002S, H/V4004S, H/V4002SM

Size		Nk Vel	200	300	400	500	600	700	800	1000
		Pt	.007	.015	.027	.042	.061	.083	.108	.169
32x30	Ac ft ²	CFM	1270	1905	2540	3175	3810	4445	5080	6350
	6.35	NC	17	18	19	21	23	25	28	34
	Throw		12-27-57	27-43-80	38-57-93	48-72-104	57-80-113	67-87-123	76-93-131	85-104-147
36x28 42x24	Ac ft ²	CFM	1330	1996	2663	3329	3995	4661	5328	6660
	6.65	NC	17	18	19	21	23	25	28	34
	Throw		12-27-59	27-44-82	39-59-95	49-73-106	59-82-116	69-89-126	77-95-134	87-106-150
36x30	Ac ft ²	CFM	1430	2146	2863	3579	4295	5011	5728	7160
	7.15	NC	17	18	19	21	23	25	28	35
	Throw		13-28-61	28-46-85	41-61-98	51-76-110	61-85-120	71-92-130	80-98-139	90-110-156
36x32 48x24	Ac ft ²	CFM	1525	2288	3051	3814	4578	5341	6104	7630
	7.63	NC	17	18	19	21	23	26	28	35
34x34	Throw		13-29-63	29-47-88	42-63-102	52-79-114	63-88-124	73-95-134	83-102-144	93-114-161
36x36	Ac ft ²	CFM	1730	2593	3455	4318	5180	6043	6905	8630
	8.65	NC	18	19	20	22	24	26	29	35
	Throw		14-31-67	31-50-94	45-67-108	56-84-121	67-94-132	78-101-143	88-108-153	99-121-171

PERFORMANCE NOTES FOR SERIES 4000

All data is tested in accordance with ANSI/ASHRAE 70-2006.

DEFINITION OF UNITS

CFM Air volume is cubic feet per minute

Nk Vel Neck Velocity is the airstream velocity in the duct just before it reaches the supply outlet; measured in feet per minute

fpm Velocity of air stream in Feet per Minute

Throw Throw distance in feet are for terminal velocities of 150 fpm, 100 fpm and 50 fpm respectively

NC Noise criterion, sound pressure level NC ratings are based on sound power level (Lw) re: 10⁻¹² watts minus a 10dB room attenuation in all octave bands

Pt Total pressures in inches of water

Ac Actual Core Free Area in square feet

SERIES 4000 PERFORMANCE DATA

MODELS H/V4002, H/V4004, H/V4002M, H/V4002S, H/V4004S, H/V4002SM

Size		Nk Vel	100	200	300	400	500	600	700	800
		Pt	.002	.007	.015	.027	.042	.061	.083	.108
42x36	Ac ft ²	CFM	1010	2020	3030	4040	5050	6060	7070	8080
	10.10	NC	15	18	19	21	22	24	27	29
	Throw			4-8-34	15-34-72	34-54-101	48-72-117	60-91-131	72-101-143	85-109-155
40x40	Ac ft ²	CFM	1070	2140	3210	4280	5350	6420	7490	8560
	10.70	NC	15	19	20	21	23	25	27	30
	Throw			4-9-35	15-35-75	35-56-104	50-75-120	62-93-134	75-104-147	87-113-159
48x36	Ac ft ²	CFM	1160	2316	3473	4629	5785	6941	8098	9254
	11.60	NC	15	19	20	21	23	25	27	30
	Throw			4-9-36	16-36-78	36-58-108	52-78-125	65-97-140	78-108-153	90-117-165
42x42	Ac ft ²	CFM	1180	2363	3545	4728	5910	7093	8275	9458
	11.80	NC	15	19	20	21	23	25	27	30
	Throw			4-9-37	16-37-78	37-59-109	52-78-126	65-98-141	78-109-155	91-118-167
44x44	Ac ft ²	CFM	1300	2599	3898	5196	6495	7794	9093	10391
	13.00	NC	16	20	21	22	24	26	28	31
	Throw			4-10-38	17-38-82	38-62-115	55-82-133	68-103-148	82-115-162	96-124-175
48x42	Ac ft ²	CFM	1360	2713	4065	5418	6770	8123	9475	10828
	13.60	NC	16	20	21	22	24	26	28	31
	Throw			4-10-40	17-39-84	39-63-117	56-84-135	70-105-151	84-117-166	98-127-179
46x46	Ac ft ²	CFM	1420	2843	4265	5688	7110	8533	9955	11378
	14.20	NC	16	20	21	22	24	26	28	31
	Throw			4-10-40	18-40-86	40-64-120	57-86-139	72-107-155	86-120-170	100-130-183
48x48	Ac ft ²	CFM	1550	3101	4653	6204	7755	9306	10858	12409
	15.50	NC	17	20	21	22	24	26	29	32
	Throw			5-10-42	19-42-90	42-67-125	60-90-145	75-112-162	90-125-177	105-135-192

PERFORMANCE NOTES FOR SERIES 4000

All data is tested in accordance with ANSI/ASHRAE 70-2006.

DEFINITION OF UNITS

CFM Air volume is cubic feet per minute

Nk Vel Neck Velocity is the airstream velocity in the duct just before it reaches the supply outlet; measured in feet per minute

fpm Velocity of air stream in Feet per Minute

Throw Throw distance in feet are for terminal velocities of 150 fpm, 100 fpm and 50 fpm respectively

NC Noise criterion, sound pressure level NC ratings are based on sound power level (Lw) re: 10⁻¹² watts minus a 10dB room attenuation in all octave bands

Pt Total pressures in inches of water

Ac Actual Core Free Area in square feet

METALAIRE

Submittal:RH Return and Exhaust Grilles 45° Fixed Blade, Roll-Formed Aluminum

Model: **RH-1** 45° Fixed Blade - Flush Surface Mount

RH-1 - Flush Surface Mount

Face View

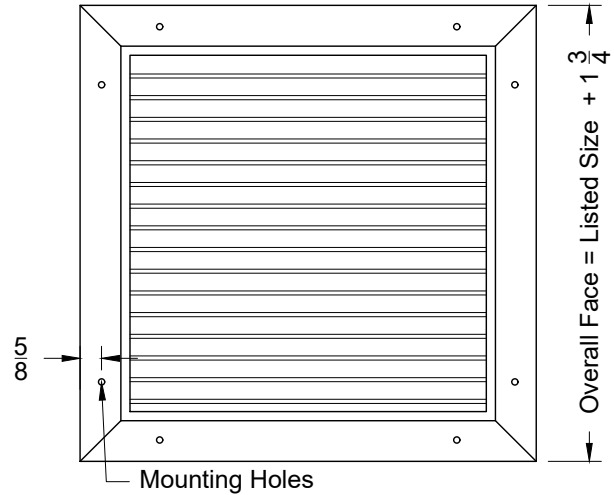
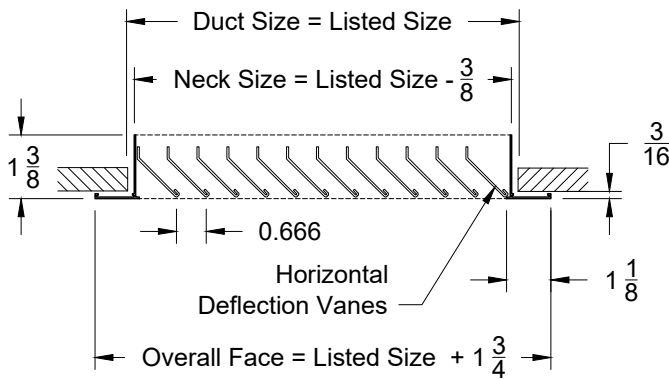

Note: This product complies with NFPA 90A-18 standard 4.3.7.3.2 and 4.3.8.3.2 and is constructed with openings through which a 1/2" sphere can not pass.

1. Available Finishes	2. Available Accessories	3. Available Options	4. Construction Details
Standard Finish: 01 White	OBDA - Aluminum OBD		<ul style="list-style-type: none"> • Odd/Fractional Sizes Available for additional charge • Oversized Units made in multiple sections • Largest single section is 48x48 • Mullion strips provided for joining units in field • Available in MRI-compatible aluminum construction <p style="text-align: right;">All Dimensions ±1/16"</p>

SERIES RH PERFORMANCE DATA

MODELS RH, RHP, RHE, SRH, RH-H, RHE-H, SRH-H

Size	Duct Area ft ²	Nk Vel	200	300	400	500	600	700	800	900	1000
		Ps	-.005	-.011	-.020	-.031	-.045	-.061	-.080	-.101	-.125
06x06	.25	CFM	50	75	100	125	150	175	200	225	250
		NC	-	-	14	17	20	22	25	27	29
08x06	.33	CFM	67	100	133	167	200	233	267	300	333
		NC	-	11	15	18	21	24	26	29	31
10x06	.42	CFM	83	125	167	208	250	292	333	375	417
		NC	-	12	16	19	22	25	27	29	32
08x08	.44	CFM	89	133	178	222	267	311	356	400	444
		NC	-	12	16	19	22	25	27	29	32
12x06	.50	CFM	100	150	200	250	300	350	400	450	500
		NC	-	13	17	20	23	25	28	30	32
16x06 12x08	.67	CFM	133	200	267	333	400	467	533	600	667
		NC	-	14	18	21	24	27	29	32	34
10x10	.69	CFM	139	208	278	347	417	486	556	625	694
		NC	10	14	18	21	24	27	29	32	34
12x10 20x06	.83	CFM	167	250	333	417	500	583	667	750	833
		NC	10	15	19	22	25	28	30	32	35
24x06 12x12	1.00	CFM	200	300	400	500	600	700	800	900	1000
		NC	11	16	20	23	26	28	31	33	35
14x12	1.16	CFM	233	250	467	583	7800	817	933	1050	1167
		NC	12	16	20	24	26	29	32	34	36
18x10 30x06	1.25	CFM	250	375	500	625	750	875	1000	1125	1250
		NC	12	17	21	24	27	29	32	34	36
14x14	1.36	CFM	272	408	544	681	817	953	1089	1225	1361
		NC	13	17	21	24	27	30	32	35	37
18x12 36x06	1.50	CFM	300	450	600	750	900	1050	1200	1350	1500
		NC	13	189	21	25	28	30	33	35	37
24x10 30x08	1.67	CFM	333	500	667	833	1000	1167	1333	1500	1667
		NC	13	18	22	25	28	31	33	34	38
18x14 42x06	1.75	CFM	350	525	700	875	1050	1225	1400	1575	1750
		NC	14	18	22	25	28	31	33	36	38
18x16 24x12	2.00	CFM	400	600	800	1000	1200	1400	1600	1800	2000
		NC	14	19	23	26	29	32	34	36	38
18x18	2.25	CFM	450	675	900	1125	1350	1575	1800	2025	2250
		NC	15	19	23	26	29	32	34	37	39

CONTINUED

SERIES RH PERFORMANCE DATA

MODELS RH, RHP, RHE, SRH, RH-H, SRH-H

Size	Duct Area ft ²	Nk Vel	200	300	400	500	600	700	800	900	1000
		Ps	-0.005	-0.011	-0.020	-0.031	-0.045	-0.061	-0.080	-0.101	-0.125
30x12	2.50	CFM	500	750	1000	1250	1500	1750	2000	2250	2500
		NC	15	20	24	27	30	32	35	37	39
20x20	2.78	CFM	556	833	1111	1389	1667	1944	2222	2500	2778
		NC	16	20	24	27	30	33	35	38	40
24x18 36x12	3.00	CFM	600	900	1200	1500	1800	2100	2400	2700	3000
		NC	16	21	24	28	31	33	36	38	40
22x22	3.36	CFM	672	1008	1344	1681	2017	2353	2689	3025	3361
		NC	17	21	25	28	31	34	36	39	41
36x14 42x12	3.50	CFM	700	1050	1400	1750	2100	2450	2800	3150	3500
		NC	17	21	25	28	31	34	36	39	41

PERFORMANCE NOTES FOR SERIES RH, RHP, RHE, SRH, RH-H, SRH-H

All data is tested in accordance with ANSI/ASHRAE 70-2006.

DEFINITION OF UNITS

CFM Cubic Feet per Minute (air)

Velocity Velocity of air stream in Feet per Minute

Ps Static pressure = Pt-Pv (inches of water column)

NC Noise criterion, Sound pressure level. NC ratings are based on sound power level (lw)
RE: 10⁻¹² watts minus a 10dB room attenuation in all octave bands.

Nk Vel Neck velocity of air stream in Feet Per Minute

CONTINUED

SERIES RH PERFORMANCE DATA

MODELS RH, RHP, RHE, SRH, RH-H, SRH-H

Size	Duct Area ft ²	Nk Vel	200	300	400	500	600	700	800	900	1000
		Ps	-0.09	-0.20	-0.36	-0.56	-0.81	-1.10	-1.43	-1.81	-2.23
24x22	3.67	CFM	733	1100	1467	1833	2200	2567	2933	3300	3667
		NC	17	21	25	29	31	34	37	39	41
30x18	3.75	CFM	750	1125	1500	1875	2250	2625	3000	3375	3750
		NC	17	22	25	29	32	34	37	39	41
48x12 24x24	4.00	CFM	800	1200	1600	2000	2400	2800	3200	3600	4000
		NC	17	22	26	29	32	35	37	39	41
30x20	4.17	CFM	833	1250	1667	2083	2500	2917	3333	3750	4167
		NC	17	22	26	29	32	35	37	39	42
36x18	4.50	CFM	900	1350	1800	2250	2700	3150	3600	4050	4500
		NC	18	22	26	29	32	35	37	40	42
36x20 30x24	5.00	CFM	1000	1500	2000	2500	3000	3500	4000	4500	5000
		NC	18	23	27	30	33	35	38	40	42
42x18	5.25	CFM	1050	1575	2100	2625	3150	3675	4200	4725	5250
		NC	18	23	27	30	33	36	38	40	43
28x28	5.44	CFM	1089	1633	2178	2722	3267	3811	4356	4900	5444
		NC	19	23	27	30	33	36	38	41	43
36x22	5.50	CFM	1100	1650	2200	2750	3300	3850	4400	4950	5500
		NC	19	23	27	30	33	36	38	41	43
48x18 36x24	6.00	CFM	1200	1800	2400	3000	3600	4200	4800	5400	6000
		NC	19	24	27	31	34	36	39	41	43
48x24 36x32	8.00	CFM	1600	2400	3200	4000	4800	5600	6400	7200	8000
		NC	20	25	29	32	35	38	40	42	44
40x36 48x30	10.00	CFM	2000	3000	4000	5000	6000	7000	8000	9000	10000
		NC	21	26	30	33	36	38	41	43	45
38x38	10.03	CFM	2006	3008	4011	5014	6017	7019	8022	9025	10028
		NC	21	26	30	33	36	39	41	43	45
42x36	10.50	CFM	2100	3150	4200	5250	6300	7350	8400	9450	10500
		NC	21	26	30	33	36	39	41	43	46
46x34	10.86	CFM	2172	3258	4344	5431	6517	7603	8689	9775	10861
		NC	22	26	30	33	36	39	41	44	46
42x38	11.08	CFM	2217	3325	4433	5542	6650	7758	8867	9975	11083
		NC	22	26	30	33	36	39	41	44	46
40x40	11.11	CFM	2222	3333	4444	5556	6667	7778	8889	10000	11111
		NC	22	26	30	33	36	39	41	44	46

CONTINUED

SERIES RH PERFORMANCE DATA

MODELS RH, RHP, RHE, SRH, RH-H, SRH-H

Size	Duct Area ft ²	Nk Vel	200	300	400	500	600	700	800	900	1000
		Ps	-0.09	-0.20	-0.36	-0.56	-0.81	-1.10	-1.43	-1.81	-2.23
48x36	12.00	CFM	2400	3600	4800	6000	7200	8400	9600	1080	12000
		NC	22	27	30	34	37	39	42	44	46
42x42	12.25	CFM	2450	3675	4900	6125	7350	8575	9800	11025	12250
		NC	22	27	30	34	37	39	42	44	46
44x44	13.44	CFM	2689	4033	5378	6722	8067	9411	10756	12100	13444
		NC	23	27	31	34	37	40	42	45	47
46x46	14.69	CFM	2939	4408	5878	7347	8817	10286	11756	13225	14694
		NC	23	27	31	35	37	40	43	45	47
48x48	16.00	CFM	3200	4800	6400	8000	9600	11200	12800	14400	16000
		NC	23	28	32	35	38	41	43	45	47

PERFORMANCE NOTES FOR SERIES RH, RHP, RHE, SRH, RH-H, SRH-H

All data is tested in accordance with ANSI/ASHRAE 70-2006.

DEFINITION OF UNITS

CFM Cubic Feet per Minute (air)

Velocity Velocity of air stream in Feet per Minute

Ps Static pressure = $P_t - P_v$ (inches of water column)

NC Noise criterion, Sound pressure level. NC ratings are based on sound power level (lw)
RE: 10^{-12} watts minus a 10dB room attenuation in all octave bands.

Nk Vel Neck velocity of air stream in Feet Per Minute

METALAIRE

Model: 3000-1 4 Cone - Adjustable - Flush Surface Mount

3000-1 - Flush Surface Mount

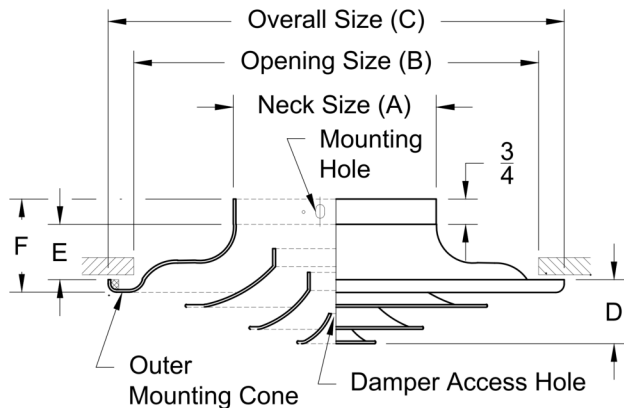

Neck	A	B	C	D	E	F
6	5 7/8	12	13 7/8	2 1/4	1 3/4	3
8	7 7/8	16	18 5/8	2 5/8	2	3 5/8
10	9 7/8	20	22 1/8	3	2 5/8	3 3/4
12	11 7/8	24	27	3 1/2	4 3/8	5
14	13 7/8	28	31 1/4	4 1/4	4 7/16	5 5/8
16	15 7/8	32	36 1/2	4 3/4	4 1/2	6 1/8
18	17 7/8	36	41 3/8	5	4 5/8	6 3/4
20	19 7/8	40	42 1/4	5 3/8	5 1/2	7 1/2
24	23 7/8	40	44 1/4	5 3/8	5 1/2	7 1/2

D = (Full Open) Horizontal Air Pattern

1. Available Finishes

Standard Finish:
 01 White

2. Available Accessories

D3 - Aluminum Radial Opposed Blade
 Damper

3. Available Options

Safety Chain

4. Construction Details

- Available Sizes Only as Listed

All Dimensions ±1/16"

SERIES 3000 PERFORMANCE DATA MODEL 3000

Neck Size	fpm Neck Vel	400	500	600	700	800	900	1000	1200	1400	1600
	Pv	0.01	0.016	0.023	0.031	0.04	0.051	0.063	0.09	0.122	0.16
	Ps Horiz.	0.011	0.018	0.026	0.035	0.046	0.059	0.072	0.105	0.145	0.19
	Ps Vert.	0.019	0.03	0.043	0.058	0.075	0.096	0.115	0.17	0.225	0.3
6	CFM	80	100	110	140	160	180	200	240	280	320
	Throw	1-3	2-4	2-5	3-6	3-7	3-8	4-8	4-9	5-10	6-12
	NC	-	-	-	20	24	27	36	36	39	44
8	CFM	140	175	210	245	280	315	350	420	490	560
	Throw	2-4	2-5	3-6	3-7	4-8	4-10	5-11	5-13	6-14	7-16
	NC	-	-	-	20	24	27	31	36	39	44
10	CFM	220	270	330	380	435	490	545	655	765	870
	Throw	2-5	3-6	3-7	4-8	5-10	6-11	6-12	7-14	8-18	9-21
	NC	-	-	-	21	25	28	32	37	40	45
12	CFM	315	390	470	550	630	710	785	940	1100	1260
	Throw	3-7	3-8	4-10	5-11	6-13	7-15	8-17	9-19	10-21	12-25
	NC	-	-	20	22	26	29	33	38	41	46
14	CFM	425	535	640	750	855	965	1070	1285	1500	1710
	Throw	3-8	4-9	5-11	6-13	7-16	8-18	9-20	11-13	13-26	15-30
	NC	-	-	20	23	27	31	34	40	43	48
16	CFM	560	700	840	980	1120	1260	1400	1680	1960	2240
	Throw	4-9	5-10	5-13	6-15	7-17	9-21	10-23	12-27	14-30	16-35
	NC	-	-	21	24	28	33	36	41	44	49
18	CFM	710	885	1060	1240	1420	1595	1770	2120	2480	2830
	Throw	4-10	5-12	6-15	7-17	9-21	11-23	13-26	15-31	16-34	18-38
	NC	-	-	21	25	29	34	37	42	45	51
20	CFM	875	1090	1310	1525	1745	1965	2180	2620	3060	3490
	Throw	4-11	6-14	7-16	8-19	9-23	17-23	13-28	15-33	18-38	20-42
	NC	-	20	22	26	30	36	39	44	47	53
24	CFM	1255	1570	1885	2200	2510	2825	3140	3770	4395	5025
	Throw	12-24	13-26	14-28	15-30	16-33	17-35	18-37	20-40	23-45	25-50
	NC	22	26	28	31	35	38	41	47	51	55

CEILING
DIFFUSERS

ROUND
CEILING DIFFUSERS

3000

PERFORMANCE NOTES FOR SERIES 3000

All data is tested in accordance with ANSI/ASHRAE 70-2006.

DEFINITION OF UNITS

- 1 Tabulated radial throw in feet is based on a 9' ceiling height, ambient supply air, MAX Throw @ Vt = 75fpm, MIN Throw @ Vt = 150fpm, and the diffuser inner cones in down position for 360° horizontal air distribution pattern.
- 2 For vertical down protection air pattern with cooling supply air temperature 20° below room temperature and diffuser inner cones in up position: multiply the tabulated radial throw values by a factor of 0.80 to obtain vertical down projection distances at MIN and MAX (Vt) terminal velocities.
- 3 For vertical down projection air pattern with heating supply air temperatures 20° above room temperature and diffuser inner cones in up position: multiply the tabulated radial throw values by a factor of 0.60 to obtain vertical down projection distances at MIN and MAX (Vt) terminal velocities.
- 4 Velocity Pressure (Pv) and Static Pressure (Ps) are in inches of water.
- 5 Series 3000 Diffusers are tested in accordance with ASHRAE 70-2006. Sound data are calculated in accordance with International Standard ISO 3741 comparison method. The NC values are based on a room absorption of 10dB for sound power level (lw) re: 10⁻¹² watts - symbol indicates NC less than 20.
- 6 All data is applicable for exposed for exposed duct mounting or ceiling installation.

METALAIRE

Submittal: 4500S
 Return and Exhaust Grilles
 38° Deflection Steel Gym Grille

Model:

4538S-1 38° Deflection Horizontal Fixed Blades - Flush Surface Mount

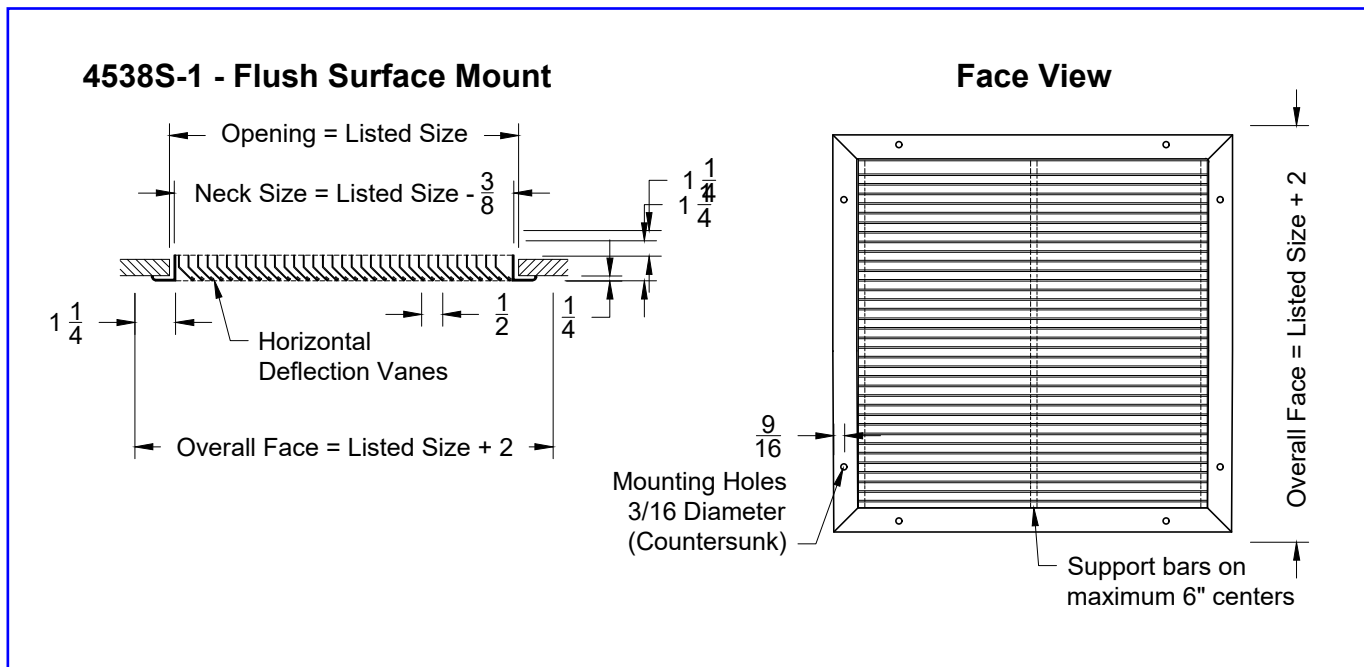

Note: This product complies with NFPA 90A-18 standard 4.3.7.3.2 and 4.3.8.3.2 and is constructed with openings through which a 1/2" sphere can not pass.

1. Available Finishes	2. Available Accessories	3. Available Options	4. Construction Details
Standard Finish: 01 White			Oversized Units made in multiple sections Largest single section is 48x48 Mullion strips provided for joining units in field All Dimensions ±1/16"

SERIES 4500 PERFORMANCE DATA

MODEL 4500/4538

Size	Duct Area ft ²	Nk Vel	300	400	500	600	700	800	900	1000	1200
		Ps	-.012	-.022	-.034	-.049	-.067	-.087	-.110	-.136	-.196
06x06	.25	CFM	63	84	105	126	147	168	189	210	252
		NC	-	-	-	-	20	22	27	28	32
08x06	.33	CFM	86	115	143	172	201	229	258	286	344
		NC	-	-	-	-	21	23	28	29	33
08x08	.44	CFM	117	156	195	234	273	313	352	391	469
		NC	-	-	-	-	26	25	30	31	35
12x06	.50	CFM	132	176	220	264	307	351	395	439	527
		NC	-	-	-	-	23	25	30	31	35
16x06 12x08	.67	CFM	180	240	299	359	419	479	539	599	719
		NC	-	-	-	21	25	27	32	33	37
12x10	.83	CFM	228	303	379	455	531	607	683	759	910
		NC	-	-	-	22	26	28	33	34	38
24x06 12x12	1.00	CFM	276	367	459	551	643	735	827	918	1102
		NC	-	-	-	22	26	28	33	34	38
14x12	1.16	CFM	323	431	539	647	755	863	970	1078	1294
		NC	-	-	20	23	27	29	34	35	39
14x14	1.36	CFM	380	506	633	759	886	1013	1139	1139	1524
		NC	-	-	21	24	28	30	35	36	40
18x18	2.25	CFM	638	851	1063	1276	1489	1701	1914	2127	2552
		NC	-	21	23	26	30	32	37	38	42
24x12 18x16	2.00	CFM	563	751	938	1126	1314	1501	1689	1877	2252
		NC	-	20	22	25	29	31	36	37	41
24x18	3.00	CFM	857	1142	1428	1714	1999	2285	2570	2856	3427
		NC	-	22	24	27	31	33	38	39	43
48x12 24x24	4.00	CFM	1151	1534	1918	2301	2685	3068	3452	3835	4602
		NC	21	24	26	29	33	35	40	41	45
30x20	4.17	CFM	1198	1598	1997	2397	2797	3196	3595	3995	4794
		NC	21	24	26	29	33	35	40	41	45
36x20 30x24	5.00	CFM	1444	1926	2407	2889	3370	3851	4333	4814	5777
		NC	22	25	27	30	34	36	41	42	46
36x22	5.50	CFM	1590	2120	2650	3180	3710	4240	4770	5300	6360
		NC	22	25	27	30	34	36	41	42	46
48x18 36x24	6.00	CFM	1738	2317	2897	3476	4055	4635	5214	5793	6952
		NC	22	25	27	30	34	36	41	42	46
48x24 36x32	8.00	CFM	2326	3101	3876	4651	5426	6201	6977	7752	9302
		NC	24	27	29	32	36	38	43	44	48
48x30 42x34	10.00	CFM	2919	3892	4865	5839	6812	7785	8758	9731	11677
		NC	25	28	30	33	37	39	44	45	49

CONTINUED

SERIES 4500 PERFORMANCE DATA MODEL 4500/4538

Size	Duct Area ft ²	Nk Vel	300	400	500	600	700	800	900	1000	1200
		Ps	-0.12	-0.22	-0.34	-0.49	-0.67	-0.87	-1.10	-1.36	-1.96
48x36	12.00	CFM	3513	4684	5855	7026	8197	9368	10539	11710	14052
		NC	25	28	30	33	37	39	44	45	49
48x40	13.33	CFM	3909	5212	6515	7818	9121	10424	11727	13030	15635
		NC	26	29	31	24	28	40	45	46	50
48x48	16.00	CFM	4701	6267	7837	9401	10968	12535	14102	15668	18802
		NC	27	30	32	35	39	41	46	47	51

PERFORMANCE NOTES FOR SERIES 4500

All data is tested in accordance with ANSI/ASHRAE 70-2006.

DEFINITION OF UNITS

CFM Cubic Feet per Minute (air)

Nk Vel Neck Velocity of air stream in Feet per Minute

Ps Negative Static pressure (inches of water column)

NC Noise criterion, Sound pressure level. NC ratings are based on sound power level (Lw)
RE: 10⁻¹² watts minus a 10dB room attenuation in all octave bands.

METALAIRE

Submittal: DGDF Door / Transfer Grille Double Flange Frame, Extruded Aluminum

Model: **DGDF** Double Flange Frame - Surface Mount

DGDF - Surface Mount

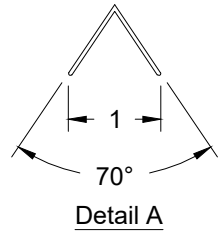
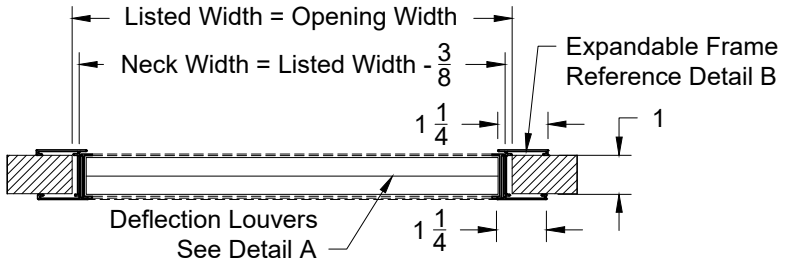

Available Sizes		
	Min	Max
Width (Neck 1)	6	48
Height (Neck 2)	4	36

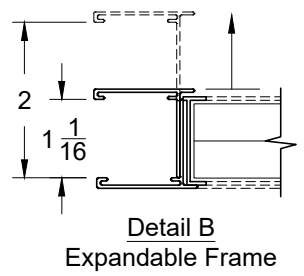
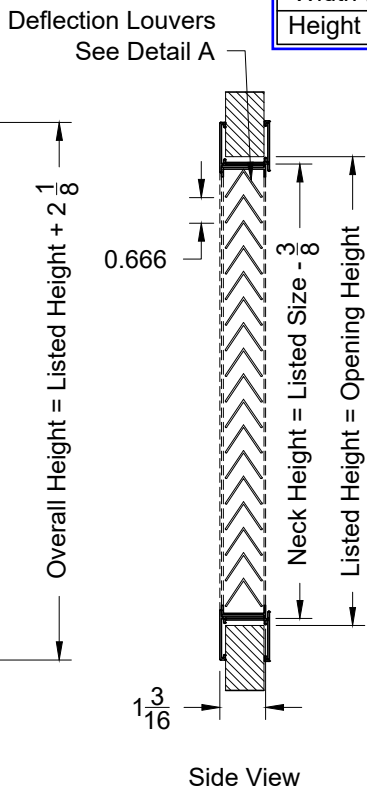
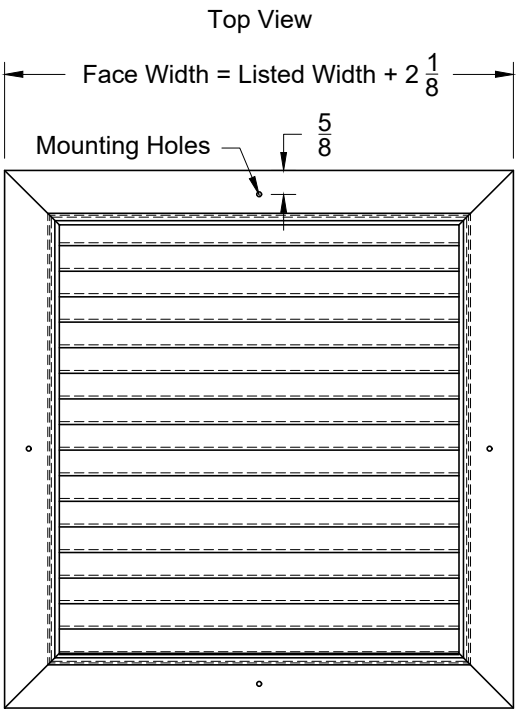

1. Available Finishes	2. Available Accessories	3. Available Options	4. Construction Details
Standard Finish: 01 White			<ul style="list-style-type: none"> Extruded Aluminum Construction Expandable frame fits doors with a minimum width of 1" maximum of 1-3/4"

All Dimensions ±1/16"

METALAIRE

Submittal: DGDF-FRS

Door / Transfer Fire Rated Grille
Double Flange Frame, C.R. Steel

Model: **DGDF-FRS** * Double Flange Frame - Surface Mount

DGDF-FRS - Surface Mount

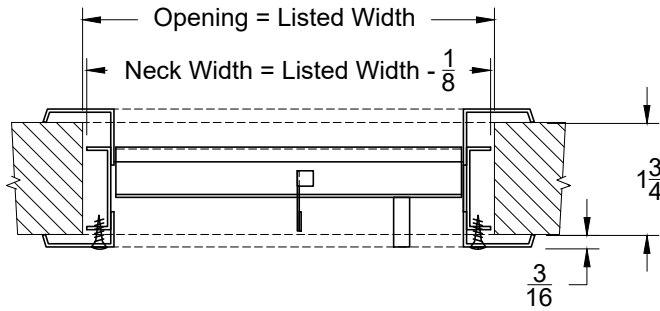

Top View

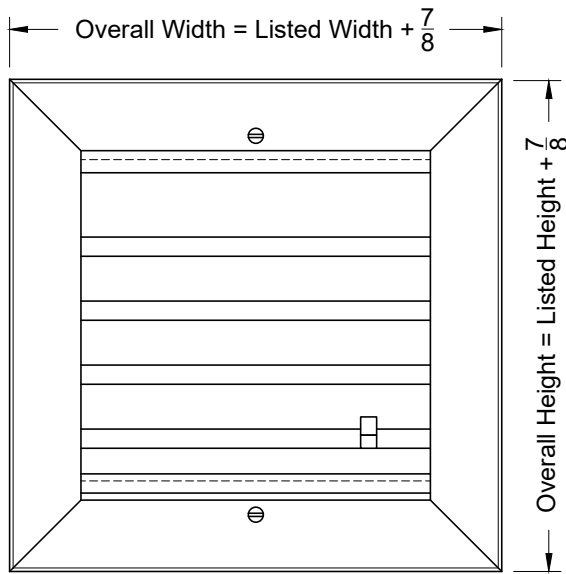

Face View

Please note maximum size for fire rated door grilles.
Qty1 - M301W - Water heater room
Qty1 - M301E - Janitor Room

Available Sizes		
	Min	Max
Width (Neck 1)	10	24
Height (Neck 2)	6	24

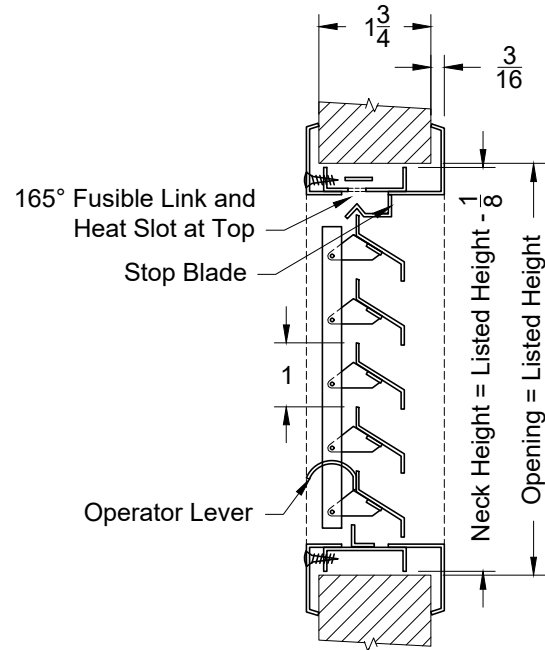

Side View

1. Available Finishes	2. Available Accessories	3. Available Options	4. Construction Details
Standard Finish: Dark Bronze Enamel			<ul style="list-style-type: none"> Material: 16ga C.R. Steel Free Area: 45% Fits 1 3/4in Doors 165° Fusible linke (90min Fire Rated) Fractional Sizes not available Mitered Corners Secured With Reinforcing Clips <p>*UL listed model 1900</p> <p>All Dimensions $\pm 1/16$"</p>

SERIES DG PERFORMANCE DATA

MODELS DGSF, DGDF

Size	Velocity	200	300	400	500	600	700	800	900	1000
	Ps	.024	.055	.097	.151	.218	.297	.388	.491	.606
6 x 6	CFM	50	75	100	125	150	175	200	225	250
	NC	<15	19	23	26	29	32	34	37	39
8 x 6	CFM	67	100	133	167	200	233	267	300	333
	NC	16	20	24	27	30	33	36	38	40
8 x 8	CFM	89	133	178	222	267	311	356	400	444
	NC	17	22	25	29	32	34	37	39	42
10 x 6	CFM	83	125	167	208	250	292	333	375	417
	NC	17	21	25	28	31	34	37	39	41
10 x 8	CFM	111	167	222	278	333	389	444	500	556
	NC	18	23	26	30	32	35	38	40	43
10 x 10	CFM	139	208	278	347	417	486	556	625	694
	NC	19	24	27	30	33	36	39	41	44
12 x 10	CFM	1678	250	333	417	500	583	667	750	833
	NC	20	24	28	31	34	37	40	42	44
12 x 12	CFM	200	300	400	500	600	700	800	900	1000
	NC	21	25	29	32	35	38	40	43	45
14 x 12	CFM	233	350	467	583	700	817	933	1050	1167
	NC	21	26	29	33	36	38	41	43	46
14 x 14	CFM	272	408	544	681	817	953	1089	1225	1361
	NC	22	26	30	33	36	39	42	44	46
16 x 12	CFM	267	400	533	667	800	933	1067	1200	1333
	NC	22	26	30	33	36	39	42	44	46
16 x 16	CFM	356	533	711	889	1067	1244	1422	1600	1778
	NC	23	28	31	35	38	40	43	45	48
18 x 12	CFM	300	450	600	750	900	1050	1200	1350	1500
	NC	23	27	31	34	37	40	42	45	47
18 x 18	CFM	450	675	900	1125	1350	1575	1800	2025	2250
	NC	24	29	32	36	39	41	44	46	49
20 x 12	CFM	333	500	667	833	1000	1167	1333	1500	1667
	NC	23	27	31	34	37	40	43	45	47
20 x 20	CFM	556	833	1111	1389	1667	1944	2222	2500	2778
	NC	25	30	33	36	39	42	45	47	50
24 x 12	CFM	400	600	800	1000	1200	1400	1600	1800	2000
	NC	24	28	32	35	38	41	43	46	48
24 x 18	CFM	600	900	1200	1500	1800	2100	2400	2700	3000
	NC	26	30	34	37	40	43	45	48	50
24 x 24	CFM	800	1200	1600	2000	2400	2800	3200	3600	4000
	NC	27	31	35	38	41	44	46	49	51
30 x 12	CFM	500	750	1000	1250	1500	1750	2000	2250	2500
	NC	25	29	33	36	39	42	44	47	49
30 x 20	CFM	833	1250	1667	2083	2500	2917	3333	3750	4167
	NC	27	31	35	38	41	44	47	49	51
30 x 24	CFM	1000	1500	2000	2500	3000	3500	4000	4500	5000
	NC	28	32	36	39	42	45	47	50	52
30 x 30	CFM	1250	1875	2500	3125	3750	4375	5000	5625	6250
	NC	29	33	37	40	43	46	48	51	53
	Throw	N/A	N/A	N/A	N/A	N/A	N/A	N/A	N/A	N/A

PERFORMANCE NOTES FOR SERIES DG

All data is tested in accordance with ANSI/ASHRAE 70-2006.

DEFINITION OF UNITS

Ps Static pressure = $P_t - P_v$ (inches of water column)

NC Noise criterion, sound pressure level NC ratings are based on sound power level (L_w) re: 10^{-12} watts minus a 10dB room attenuation in all octave bands

Throw Non-isothermal horizontal throw (supply air temperature 15°F colder than average room temperature); values are for 150, 100 and 50fpm velocities

Velocity fpm (Feet per Minute)

CFM Cubic Feet per Minute (Air)

METALAIRE

Submittal: AFLC-AA Architectural Formations Linear Diffusers Exposed Face

Model: **AFLC-AA** Concealed Mounting - Border A & Border A - Exposed Face

AFLC-AA - Exposed Face

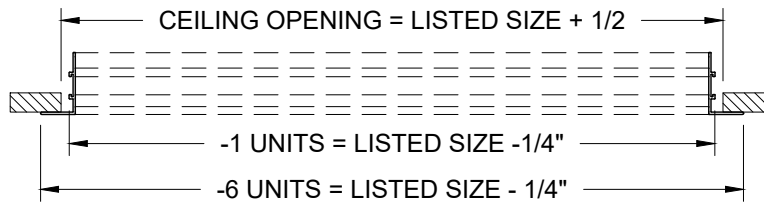
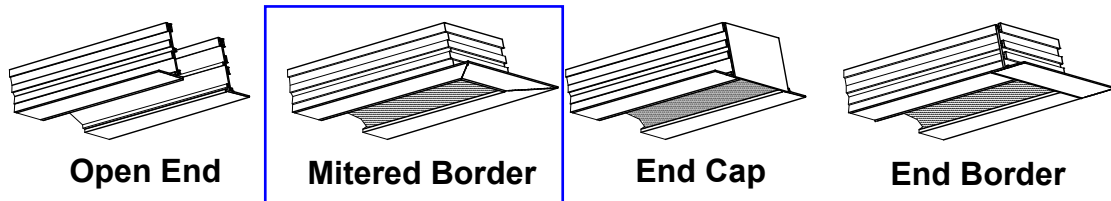
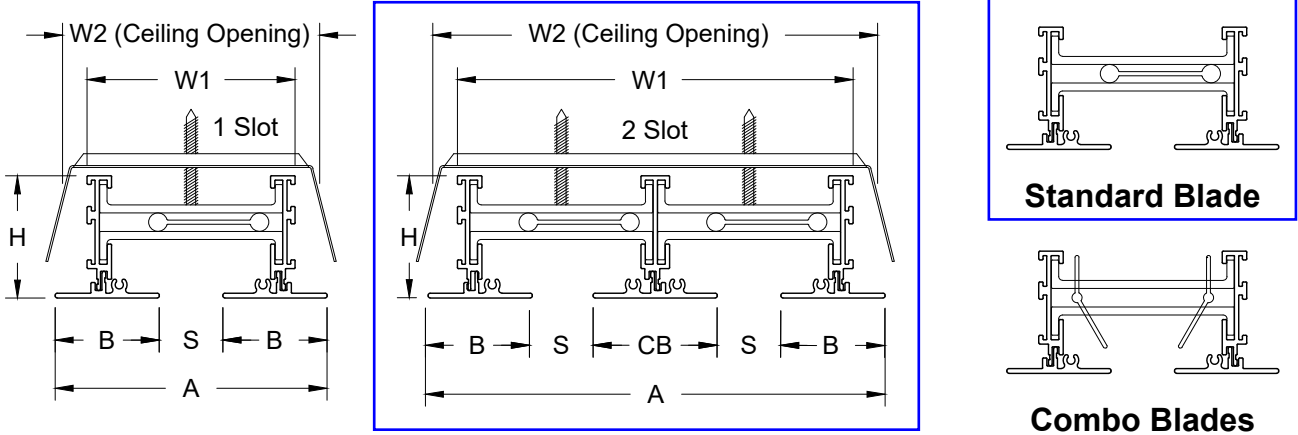

Model	S Slot Width	Face Width		Neck Width				B Border Width	CB Border Width	H Height
		1 Slot	2 Slot	1 Slot	1 Slot	2 Slot	2 Slot			
AFLC-10	1	4 1/4	7 3/16	3 1/4	4	6 3/16	6 15/16	1 5/8	1 15/16	2
AFLC-15	1 1/2	4 3/4	8 3/16	3 3/4	4 1/2	7 3/16	7 15/16	1 5/8	1 15/16	2
AFLC-20	2	5 1/4	9 3/16	4 1/4	5	8 3/16	8 15/16	1 5/8	1 15/16	2
AFLC-25	2 1/2	6 3/4	12 3/16	5 3/4	6 1/2	11 3/16	11 15/16	2 1/8	2 15/16	2 1/2
AFLC-30	3	7 1/4	13 3/16	6 1/4	7	12 3/16	12 15/16	2 1/8	2 15/16	2 1/2

1. Available Finishes	2. Available Accessories	3. Available Options	4. Construction Details
Standard Finish: 20 - White Face and Black Interior		1EC - (1) End Cap 2EC - (2) End Caps 1EB - (1) End Border 2EB - (2) End Borders OO - Open / Open MM - Mitered / Mitered MO - Mitered / Open	<ul style="list-style-type: none"> Material: Extruded Aluminum C - Combo Pattern Controller S - Standard Pattern Controller Standard Single Section size: (12" minimum - 72" maximum) Lengths larger than 72" made in multiple sections

All Dimensions ±1/16"

METALAIRE

Submittal: UP-AFLC-10

Architectural Formations
Linear Diffuser Plenum with Concealed Mounting

Model: **UP-AFLC-10** Linear Diffuser Plenum with Concealed Mounting - 1" Slot - Non Insulated

UP-AFLC-10 - 1" Slot - Non Insulated

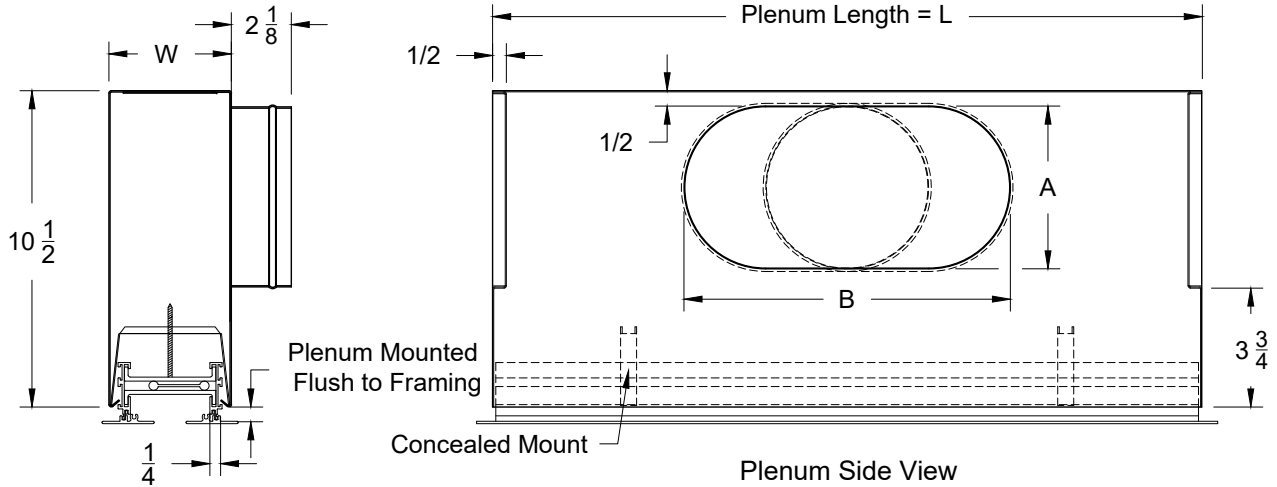

Plenum (Installed) End View

Plenum Side View

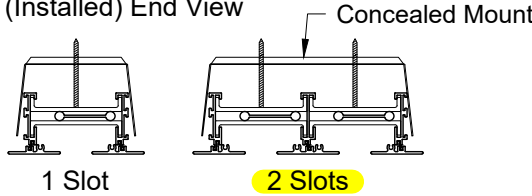

Models	Slot Width	Number of Slots	W (Width)
UP-AFLC-10	1	1	4
UP-AFLC-10	1	2	7

Inlet Chart				Length
Size	Type	A	B	
6	Round	5 7/8	-	L
7	Oval	5 7/8	7 1/4	24
8	Oval	5 7/8	8 3/8	36
9	Oval	5 7/8	10	48
10	Oval	5 7/8	11 9/16	60
12	Oval	5 7/8	14 13/16	72
14	Oval	5 7/8	17 13/16	

L=Listed Size								
Model	Frame Type	2-EB	1-EB	OO	1-EC	2-EC	MM	MO
UP-AFLC-10	-1	- 1/16	- 1/16	- 1/16	- 1/16	-1/8	- 1/16	- 1/16
UP-AFLC-10	-6	- 2 1/4	-1 1/8	- 1/16	- 1/16	-1/8	-1 1/8	-5/8

1. Available Finishes	2. Available Accessories	3. Available Options	4. Construction Details
	ID - Inlet Damper	MRI - MRI Construction 1EC - (1) End Cap 2EC - (2) End Caps OO - Open / Open	<ul style="list-style-type: none"> Standard Lengths: 24, 36, 48, 60, 72

All Dimensions ±1/16"

AFL FORMATIONS PERFORMANCE DATA

2 SLOT STANDARD BLADE HORIZONTAL THROW WITH METALAIRE PLENUM

Two Slot — 1" Slot Width	Horizontal Throw	8" Oval Inlet	2 ft.	CFM	115	145	175	205	235	260	290	320
				Ps	.046	.072	.103	.140	.183	.232	.286	.346
Pt	.054	.084	.121	.165	.215	.271	.335	.405				
NC	-	16	22	27	31	35	38	40				
Throw	7-11-16	9-13-18	11-14-19	12-15-21	13-16-22	14-17-24	14-18-25	15-19-26				
Two Slot — 1" Slot Width <td rowspan="2">Horizontal Throw <td rowspan="2">8" Oval Inlet <td rowspan="2">4 ft.</td> <td>CFM</td> <td>235</td> <td>290</td> <td>350</td> <td>410</td> <td>465</td> <td>525</td> <td>580</td> <td>640</td> </td></td>	Horizontal Throw <td rowspan="2">8" Oval Inlet <td rowspan="2">4 ft.</td> <td>CFM</td> <td>235</td> <td>290</td> <td>350</td> <td>410</td> <td>465</td> <td>525</td> <td>580</td> <td>640</td> </td>	8" Oval Inlet <td rowspan="2">4 ft.</td> <td>CFM</td> <td>235</td> <td>290</td> <td>350</td> <td>410</td> <td>465</td> <td>525</td> <td>580</td> <td>640</td>	4 ft.	CFM	235	290	350	410	465	525	580	640
				Ps	.051	.080	.115	.156	.204	.257	.318	.384
Pt	.083	.129	.186	.254	.329	.418	.513	.622				
NC	-	18	24	29	33	37	40	42				
Throw	10-15-22	12-18-25	15-19-28	17-21-30	18-22-32	19-24-34	20-25-35	21-26-37				
Two Slot — 1" Slot Width <td rowspan="2">Horizontal Throw <td rowspan="2">8" Oval Inlet <td rowspan="2">5 ft.</td> <td>CFM</td> <td>295</td> <td>365</td> <td>440</td> <td>510</td> <td>585</td> <td>655</td> <td>730</td> <td>800</td> </td></td>	Horizontal Throw <td rowspan="2">8" Oval Inlet <td rowspan="2">5 ft.</td> <td>CFM</td> <td>295</td> <td>365</td> <td>440</td> <td>510</td> <td>585</td> <td>655</td> <td>730</td> <td>800</td> </td>	8" Oval Inlet <td rowspan="2">5 ft.</td> <td>CFM</td> <td>295</td> <td>365</td> <td>440</td> <td>510</td> <td>585</td> <td>655</td> <td>730</td> <td>800</td>	5 ft.	CFM	295	365	440	510	585	655	730	800
				Ps	.056	.088	.126	.172	.224	.283	.349	.422
Pt	.107	.165	.239	.323	.423	.533	.660	.795				
NC	-	20	26	31	35	38	41	43				
Throw	13-20-25	17-24-28	20-26-31	23-28-33	25-30-35	26-32-38	27-34-40	29-35-42				
Two Slot — 1" Slot Width <td rowspan="2">Horizontal Throw <td rowspan="2">10" Oval Inlet <td rowspan="2">2 ft.</td> <td>CFM</td> <td>115</td> <td>145</td> <td>175</td> <td>205</td> <td>235</td> <td>260</td> <td>290</td> <td>320</td> </td></td>	Horizontal Throw <td rowspan="2">10" Oval Inlet <td rowspan="2">2 ft.</td> <td>CFM</td> <td>115</td> <td>145</td> <td>175</td> <td>205</td> <td>235</td> <td>260</td> <td>290</td> <td>320</td> </td>	10" Oval Inlet <td rowspan="2">2 ft.</td> <td>CFM</td> <td>115</td> <td>145</td> <td>175</td> <td>205</td> <td>235</td> <td>260</td> <td>290</td> <td>320</td>	2 ft.	CFM	115	145	175	205	235	260	290	320
				Ps	.037	.058	.083	.112	.147	.185	.229	.276
Pt	.041	.064	.092	.125	.163	.205	.254	.307				
NC	-	16	22	27	31	35	38	40				
Throw	7-11-16	9-13-18	11--14-19	12-15-21	13-16-22	14-17-24	14-18-25	15-19-26				
Two Slot — 1" Slot Width <td rowspan="2">Horizontal Throw <td rowspan="2">10" Oval Inlet <td rowspan="2">4 ft.</td> <td>CFM</td> <td>235</td> <td>290</td> <td>350</td> <td>410</td> <td>465</td> <td>525</td> <td>580</td> <td>640</td> </td></td>	Horizontal Throw <td rowspan="2">10" Oval Inlet <td rowspan="2">4 ft.</td> <td>CFM</td> <td>235</td> <td>290</td> <td>350</td> <td>410</td> <td>465</td> <td>525</td> <td>580</td> <td>640</td> </td>	10" Oval Inlet <td rowspan="2">4 ft.</td> <td>CFM</td> <td>235</td> <td>290</td> <td>350</td> <td>410</td> <td>465</td> <td>525</td> <td>580</td> <td>640</td>	4 ft.	CFM	235	290	350	410	465	525	580	640
				Ps	.041	.064	.092	.125	.163	.206	.254	.307
Pt	.057	.089	.128	.175	.227	.288	.354	.429				
NC	-	18	24	29	33	37	40	42				
Throw	10-15-22	12-18-25	15-19-28	17-21-30	18-22-32	19-24-34	20-25-35	21-26-37				
Two Slot — 1" Slot Width <td rowspan="2">Horizontal Throw <td rowspan="2">10" Oval Inlet <td rowspan="2">5 ft.</td> <td>CFM</td> <td>295</td> <td>365</td> <td>440</td> <td>510</td> <td>585</td> <td>655</td> <td>730</td> <td>800</td> </td></td>	Horizontal Throw <td rowspan="2">10" Oval Inlet <td rowspan="2">5 ft.</td> <td>CFM</td> <td>295</td> <td>365</td> <td>440</td> <td>510</td> <td>585</td> <td>655</td> <td>730</td> <td>800</td> </td>	10" Oval Inlet <td rowspan="2">5 ft.</td> <td>CFM</td> <td>295</td> <td>365</td> <td>440</td> <td>510</td> <td>585</td> <td>655</td> <td>730</td> <td>800</td>	5 ft.	CFM	295	365	440	510	585	655	730	800
				Ps	.045	.070	.101	.137	.179	.227	.279	.338
Pt	.071	.110	.159	.215	.281	.354	.438	.528				
NC	-	20	26	31	35	38	41	43				
Throw	13-20-25	17-24-28	20-26-31	23-28-33	25-30-35	26-32-38	27-34-40	29-35-42				

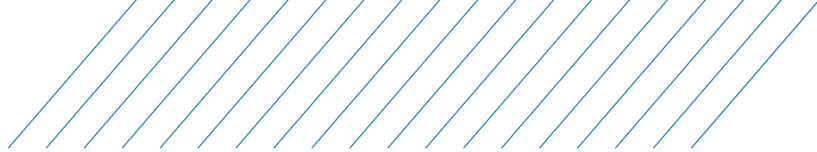

PERFORMANCE NOTES FOR FORMATIONS SERIES

All data is tested in accordance with ANSI/ASHRAE 70-2006.

DEFINITION OF UNITS

CFM Cubic Feet per Minute (air)

CFM/LF Cubic Feet per Minute per Linear Foot (air)

Velocity Velocity of air stream in Feet per Minute

Ps Negative static pressure (inches of water column)

NC Noise criterion, sound pressure level NC ratings are based on sound power level (Lw) re: 10^{-12} watts minus a 10dB room attenuation in all octave bands

1. All pressures are given in inches of water.
2. Isothermal throws are given for velocities of 150, 100 and 50 FPM.
3. Throw values are based on a 1-way discharge from the slot with the controller set at 0 discharge. For 2-way discharges, throw is based upon the number and size of the slots throwing in each direction, with the total supply air flow split equally between all slots in the unit.
4. Data was collected in accordance to ASHRAE Standard 70-2006 "Method of Testing for Rating the Performance of Air Outlets and Inlets"
5. Correction factor tables are only to be used with continuous pressurized ceiling plenum performance data.

Table 1. NC Correction For Length

Length (feet)	2	4	6	8	10
Supply	-2	+0	+2	+3	+5
Return	+0	+3	+5	+6	+8

Table 2. Throw Correction Multiplier For Length

Length (feet)	2	4	8	10	12
Throw Correction	0.72	0	1.5	1.7	1.8

Submittal # 85087

APPROVAL REQUIRED

Project 22104386-MECH-1- Brampton Victoria Park Arena
Leader Nevin Wong
Job Site Brampton Victoria Park Arena
Submission Date 2025-01-29
Sold To CONSULT MECH
Submitted By Lindsay Grahame

Contacts

Role	Customer	Contact	Our Rep
General Contractor	Rafat General Contracing Inc		
Mechanical Contractor	Con-Sult Mechanical Inc.*	Mohammed Ali Khan Lodhi	Nevin Wong
Mechanical Contractor	Con-Sult Mechanical Inc.*	Paul Leddy	Nevin Wong
Designer	WSP MMM Group		Alex Forsea

Deliverables

Track #	289038		
Tag	BDD		
Description	Backdraft Dampers		
Manufacturer	Ventex		
Production Lead Time	6 - 8 weeks		
Revision #	0		

Notes:

Contractor to confirm size, quantities, and counterbalance arrangement prior to ordering.

Lead times are estimated and subject to change on short notice

Attention:

- 1) HTS will provide equipment in accordance with the attached shop drawings.
- 2) Upon approved submittal and customer release, HTS will release equipment to fabrication per the published lead times. Any storage fees associated with project schedule changes will be the responsibility of the purchaser.
- 3) HTS can provide freight and logistics to the purchaser as an added benefit of doing business with HTS. When freight is received by the purchaser, any noticeable damage must be recorded. Otherwise, HTS is not responsible for subsequent damage claims.

Approval Stamps

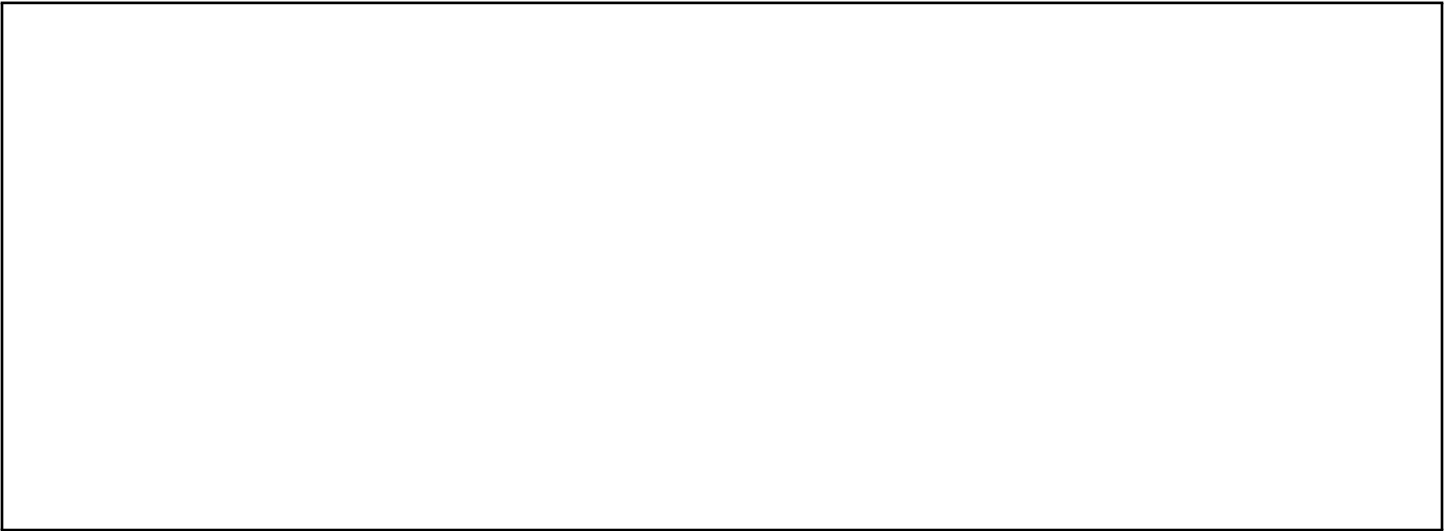
A large, empty rectangular box with a thin black border, intended for placing approval stamps. The box is currently blank.

Specifications

✓ 2.17

BACKDRAFT DAMPERS

- .1 Nailor Industries Model 1370CB counterbalanced backdraft dampers, vertical or horizontal mounting, 50 mm (2") wide, sized as shown and complete with:
 - .1 extruded 6063-T5 aluminum frame, 2.3 mm (0.090") nominal wall thickness, with mitred corners;
 - .2 extruded 6063-T5 aluminum blades, 1.3 mm (0.050") nominal wall thickness on 92 mm (3-5/8") centres, and with extruded PVC blade seals;
 - .3 corrosion-resistant synthetic bearings;
 - .4 adjustable plated steel counterweights mounted internally in the airstream;
 - .5 concealed blade linkage located out of the airstream.

Backdraft Dampers



LOUVERS & BACK DRAFT DAMPERS

1200 / 1205 / 1207
EXTRUDED ALUMINUM BACK DRAFT DAMPER

The Ventex **BDD** is a superior concept in back draft dampers. This unique, all aluminum product eliminates the shortcomings of previous designs on the market. Pivot pins that quickly wear out or rust, or rivets that shake loose and pull through the blade are no longer a problem. The extruded blades are cleverly engineered to combine strength and durability with smooth operation by virtue of their aerodynamic design.

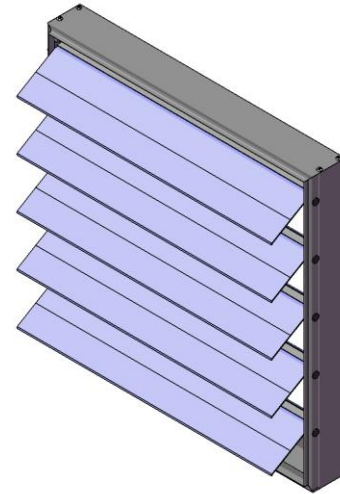
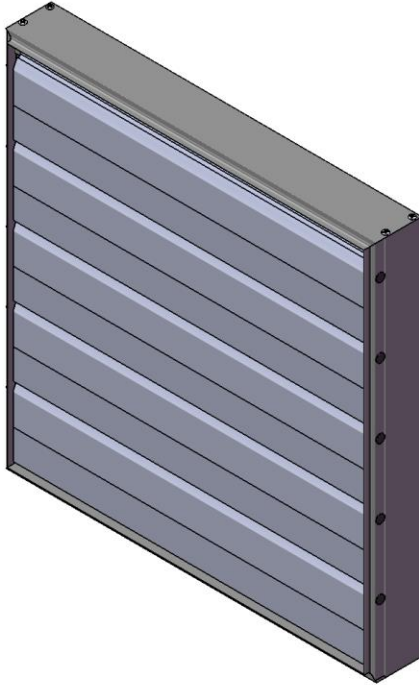

*DM MODEL SHOWN

Contractor to confirm mounting

STANDARD CONSTRUCTION	
MATERIAL:	EXTRUDED ALUMINUM - 6063-T5 ALLOY
FRAME STYLE:	SPECIFY DM FOR DUCT MOUNT FRAME SPECIFY FM FOR FLANGE FRAME (1 1/2" FLANGE) SPECIFY FFM FOR FRONT FLANGE FRAME (1 1/2" FLANGE)
DEPTH (BLADES CLOSED):	2.75" (70 mm)
DEPTH (BLADES OPEN):	5.625" (143 mm)
FRAME THICKNESS:	0.062" (1.57 mm)
BLADE THICKNESS:	0.062" (1.57 mm)
BLADE CENTRES:	3.75" (95 mm)
SEALS:	VINYL BLADE SEAL
OPERATION METHOD:	GRAVITY
FINISH:	MILL FINISH (ONLY)

SIZE LIMITATIONS		
	MINIMUM	MAXIMUM
WIDTH	8" (203 mm)	60" (1524 mm)
HEIGHT	8" (203 mm)	60" (1524 mm)
AREA	0.44 ft ² (0.04 m ²)	25 ft ² (2.32 m ²)

*DM AND FFM DAMPERS WILL BE MANUFACTURED 1/4" (6.4 mm) SMALLER THAN GIVEN OPENING DIMENSIONS UNLESS OTHERWISE SPECIFIED
*EM DAMPERS WILL BE MANUFACTURED TO THE EXACT SIZE OF GIVEN OPENING DIMENSIONS UNLESS OTHERWISE SPECIFIED



LOUVERS & BACK DRAFT DAMPERS

1200 / 1205 / 1207
EXTRUDED ALUMINUM BACK DRAFT DAMPER

FRAME STYLE

DM
DUCT MOUNT

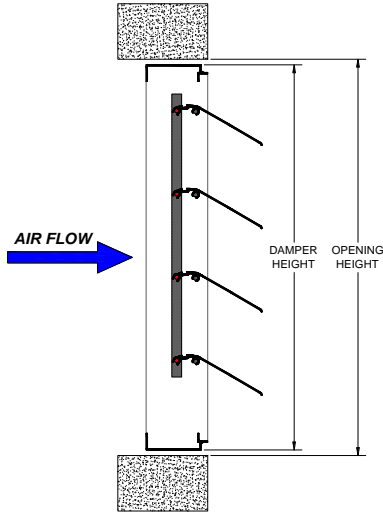

*DM DAMPER SIZE = OPENING SIZE - 1/4"

FM
FLANGE MOUNT

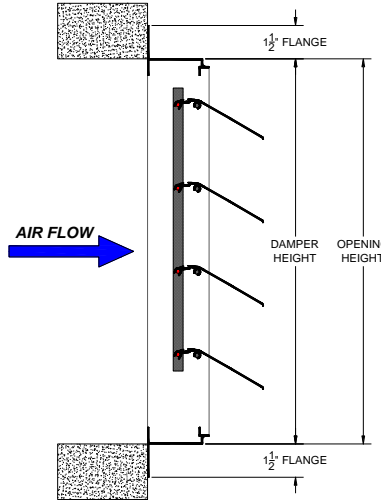

*FM DAMPER SIZE = OPENING SIZE

FFM
FRONT FLANGE MOUNT

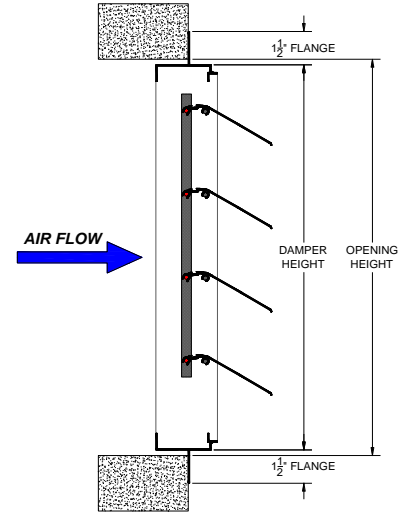

*FFM DAMPER SIZE = OPENING SIZE - 1/4"

AIR LEAKAGE - BDD

FIGURE 5.4, TEST SIZE 24" x 24"

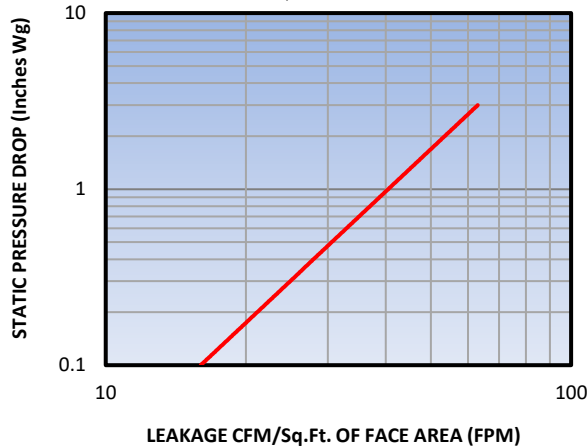

*DAMPER CLOSED

PRESSURE DROP - BDD

FIGURE 5.5, TEST SIZE 24" x 24"

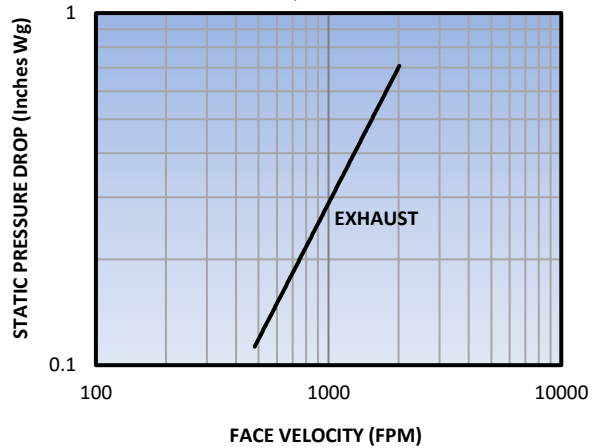

*DAMPER OPEN

*AIR LEAKAGE IS BASED UPON OPERATION BETWEEN 50°F (10°C) – 104°F (40°C)
*TEST RESULTS DO NOT INCLUDE THE EFFECTS OF BIRDSCREEN

RECOMMENDED SPECIFICATION

Furnish and install back draft damper model BDD as manufactured by Ventex Inc, Bolton, Ontario. Dampers must be licensed to bear the AMCA seal. Dampers shall be 2.75" (70 mm) deep when the blades are closed and 5.625" (143 mm) when the blades are open. Blades shall be 0.062" (1.57 mm) extruded 6063-T5 aluminum alloy and frame shall be 0.062" (1.57 mm) extruded 6063-T5 aluminum alloy. The blades must have vinyl edge seals integral to each blade. Linkage is to be concealed from the front view of the damper and cannot be mechanically fastened to the damper blades.

CERTIFIED RATINGS

Ventex Inc. certifies that the BDD Back Draft Damper shown here is licensed to bear the AMCA Seal. The ratings shown are based on tests and procedures performed in accordance with AMCA Publication 511 and comply with the requirements of the AMCA Certified Ratings Program. The Certified Ratings Seal applies to air performance and air leakage ratings.





LOUVERS & BACK DRAFT DAMPERS

1200 / 1205 / 1207
EXTRUDED ALUMINUM BACK DRAFT DAMPER

COUNTER BALANCE ARRANGEMENTS

Contractor to confirm counter balance arrangement

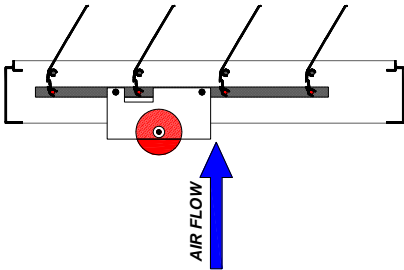

1
MOUNT CONFIGURATION: HORIZONTAL
AIR FLOW: UPWARD
ASSIST: OPEN

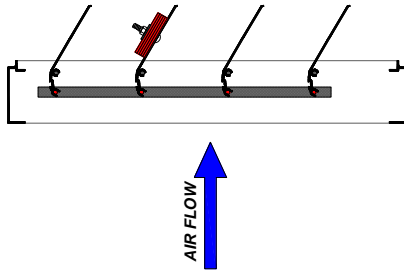

2
MOUNT CONFIGURATION: HORIZONTAL
AIR FLOW: UPWARD
ASSIST: CLOSE

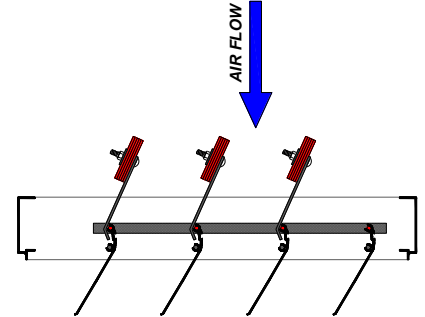

3
MOUNT CONFIGURATION: HORIZONTAL
AIR FLOW: DOWNWARD
ASSIST: CLOSE

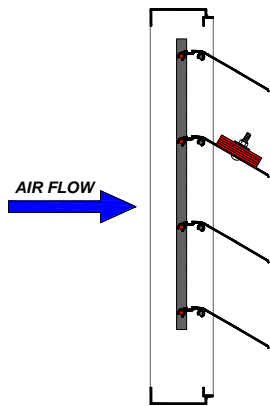

4
MOUNT CONFIGURATION: VERTICAL
ASSIST: CLOSE

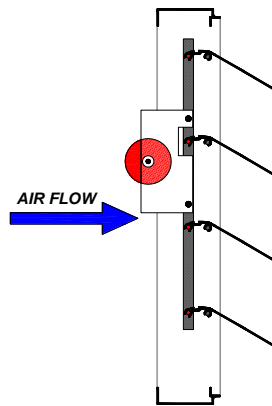

5
MOUNT CONFIGURATION: VERTICAL
ASSIST: OPEN

Submittal # 85088

APPROVAL REQUIRED

Project 22104386-MECH-1- Brampton Victoria Park Arena
Leader Nevin Wong
Job Site Brampton Victoria Park Arena
Submission Date 2025-01-29
Sold To CONSULT MECH
Submitted By Lindsay Grahame

Contacts

Role	Customer	Contact	Our Rep
General Contractor	Rafat General Contracing Inc		
Mechanical Contractor	Con-Sult Mechanical Inc.*	Mohammed Ali Khan Lodhi	Nevin Wong
Mechanical Contractor	Con-Sult Mechanical Inc.*	Paul Leddy	Nevin Wong
Designer	WSP MMM Group		Alex Forsea

Deliverables

Track #	289040	289039	
Tag	FSD	FD	
Description	FSD - Fire Smoke Damper	Fire Dampers	
Manufacturer	POTTORFF	POTTORFF	
Production Lead Time	5 - 7 weeks	5 - 7 weeks	
Revision #	0	0	

Notes:

Contractor to confirm size, quantities, orientation, and type prior to ordering.

Lead times are estimated and subject to change on short notice

Attention:

- 1) HTS will provide equipment in accordance with the attached shop drawings.
- 2) Upon approved submittal and customer release, HTS will release equipment to fabrication per the published lead times. Any storage fees associated with project schedule changes will be the responsibility of the purchaser.
- 3) HTS can provide freight and logistics to the purchaser as an added benefit of doing business with HTS. When freight is received by the purchaser, any noticeable damage must be recorded. Otherwise, HTS is not responsible for subsequent damage claims.

Approval Stamps

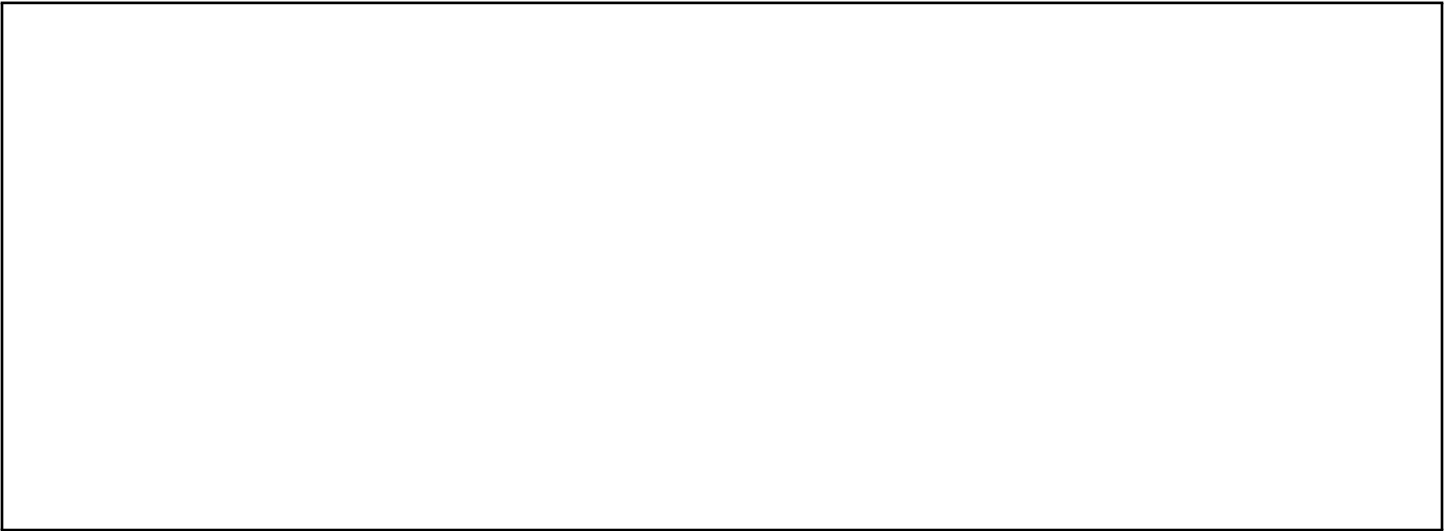
A large, empty rectangular box with a thin black border, intended for placing approval stamps. The box is currently blank.

Specifications

2.19 COMBINATION FIRE/SMOKE DAMPERS

- .1 Nailor Industries Series 1220, ULC listed to CAN/ULC S112 and CAN/ULC S112.1, meeting requirements of NFPA 80, 90A, 92, 101 and 105, consisting of type A, B, or C fusible link fire dampers as required and a fail-safe, opposed blade, normally closed, motor operated smoke damper complete with factory installed and tested 120 V electric actuator. Belimo Actuators selected as per damper size.
- .2 ULC 1-1/2 hour fire rated and ULC Class I leakage rated for smoke, and equipped with a 74°C (165°F) ULC classified fusible link that will cause damper to close and lock independent of actuator when duct temperature reaches maximum temperature of damper assembly.
- .3 Supply damper with factory installed sleeves of minimum 400 mm (16") length, field verified by contractor dependent on wall thickness. Caulk sleeves to ULC requirements and constructed of 20 gauge for sizes up to 2.1 m (84") wide and 18 gauge for sizes greater than 2.1 m (84") wide.
- .4 Dampers in ductwork other than galvanized steel are to be as specified above but constructed of type 316 stainless steel.

2.18 FUSIBLE LINK DAMPERS

- .1 Curtain blade type, dynamic, galvanized steel (unless otherwise specified) fusible link dampers, ULC classified to CAN/ULC S112 and in accordance with NFPA 90A requirements, factory tested for closure under airflow, 1-1/2 hour or 3 hour rated as required, and complete with a constant force type 301 stainless steel closure spring, a blade lock assembly, a steel sleeve, retaining angles, and, unless otherwise specified, a 74°C (165°F) rated standard fusible link.
- .2 Fusible link dampers are to be Type "B" or Type "C" (as required) with folded curtain blade out of air stream except where damper size or location requires use of type "A" dampers with curtain blade in air stream.
- .3 Dampers in ductwork other than galvanized steel are to be as specified above but constructed of type 316 stainless steel.

Combination Fire/Smoke Dampers

Application

The FSD-151 combination fire smoke damper employs airfoil blades for point-of-origin control of fire and smoke in static and dynamic smoke management systems. The FSD-151 is qualified to 4,000 ft/min (20.3 m/s) and 8 in.wg. (2.0 kPa) and may be installed in vertical walls or partitions, or horizontally in floors or assemblies with fire resistance ratings up to 2 hours.

Standard Construction

Frame: 5" x 1" (127 x 25) galvanized steel hat channel with interlocking corner gusset. Equivalent to 13 gauge (2.4) channel frame. Low profile head and sill are used on sizes less than 13" (330) high.

Blades: 6" x 14 gauge (152 x 2.0) equivalent galvanized — steel airfoil.

Sleeve: 16" x 20 gauge (406 x 1.0) galvanized steel.

Axles: ½" (13) diameter plated steel hex.

Linkage: Concealed in frame.

Bearings: Stainless steel oilite, sleeve-type.

Seals: Silicone blade edge seals integrally rolled and mechanically fastened to blades. Flexible metal jamb seals.

Actuator: 120 VAC, power-open, spring-close, external mount.

Fire Closure Device: HS-10 (electric) or PFV (pneumatic)

Fire Closure Temperature: 165°F (75°C).

Minimum Size: 8" x 6" (203 x 152)

Maximum Size: Single section: 32" x 48" (813 x 1219)
Multiple section: Vertical: 144" x 48" (3658 x 1219) or
128" x 96" (3251 x 2438)
Horizontal: 120" x 96" (3048 x 2438)

Options

Installation: Vertical Mount Horizontal Mount

Contractor to confirm mounting

PI-50 — Dual position indicator switch package.

Ratings

UL 555 Fire Resistance Rating: 1½ hour (vertical and horizontal)

UL 555S Leakage Class: 1 [8 cfm/sq.ft. @ 4 in.wg.]
[(0.04 m³/s/m² @ 1.0 kPa)]

UL HNLJ.V-5: Ventilation Duct Assemblies

Maximum Dynamic Closure Velocity:** 4,000 fpm (20.3 m/s)

Maximum UL555S Rated Pressure: 8 in.wg. (2.0 kPa)

Maximum Temperature:** 350°F (177°C)

Listings

UL 555 and 555S listing: R11767

CSFM listing: 3225-0368:115 and 3230-0368:116

New York City MEA listing: 295-98-E

Meets NFPA Standards: 90A, 92A, 92B and 101

Meets Building Code Standards: IBC, NBC, NFPA, SBC and UBC

CAN/ULC-S112 Classified Dynamic Fire Damper

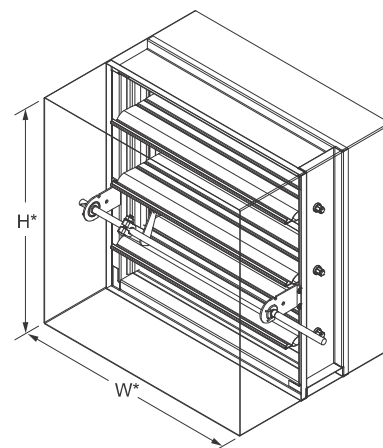

Model **FSD-151**
(standard)

*Damper dimensions furnished approximately 1/4" (6) undersize. (sleeve thickness not included)

† 24V Modulating option on horizontal mount dampers only available with parallel blade action.

**Special Sizing	Power Close Option	24V Modulating Option
Maximum Single Section	32" x 36" (813 x 914)	32" x 24" (813 x 610)
Maximum Multiple Section - Vertical	N/A	128" x 48" or 144" x 24" (3521 x 1219 or 3658 x 610)
Maximum Multiple Section - Horizontal	N/A	120" x 48" (3048 x 1219)
Maximum Dynamic Closure Velocity	2000 fpm (10.2 m/s)	2000 fpm (10.2 m/s)
Maximum Temperature	212°F (100°C)	250°F (121°C)



Air Performance

Pottorff certifies that the model FSD-151 shown herein is licensed to bear the AMCA seal. The ratings shown are based on tests and procedures performed in accordance with AMCA publication 511 and comply with the requirements of the AMCA Certified Ratings Program. The AMCA Certified Ratings Seal applies to air performance ratings only.

Information is subject to change without notice or obligation.

NOTE: Dimensions in parentheses () are millimeters.

Actuator and Sleeve Dimensional Data

The drawings and corresponding table illustrate the position of the damper when mounted in a factory sleeve and the relative space required for a given actuator. The standard mounting locations provide enough space for installation of retaining angles and duct connections.

Damper Height	Actuator Model							
	FSLF120 FSLF24	FSNF120 FSNF24	GGD221 GGD121	ML4115 ML8115	MS4120 MS8120	331-4826	331-2998	
F	6"-7"	5"	7"	9"	5"	8"	9"	13"
	8"-9"	4"	7"	8"	4"	8"	8"	12"
	10"-11"	1"	4"	6"	1"	5"	5"	9"
	12"-13"	0"	3"	5"	0"	4"	4"	8"
	14"	0"	2"	4"	0"	3"	4"	8"
	15"-16"	0"	1"	3"	0"	2"	3"	7"
	17"	0"	3"	5"	0"	4"	5"	9"
	18" and 23"	0"	0"	0"	0"	0"	0"	3"
	19"-20" and 25"	0"	0"	0"	0"	0"	0"	2"
	21"-22" and 24"	0"	0"	0"	0"	0"	0"	0"
26"-27"	0"	0"	0"	0"	0"	0"	1"	
>27"	0"	0"	0"	0"	0"	0"	0"	
T	6" and 10"	3"	3"	3"	3"	4"	3"	3"
	7" and 11"-12"	2"	2"	2"	2"	3"	2"	2"
	8", 13"-14" and 21"	1"	1"	1"	1"	2"	1"	1"
	9", 15"-17" and 20"	0"	0"	0"	0"	0"	0"	0"
	18"-19"	0"	1"	1"	0"	2"	1"	1"
	22"-23" and >24"	0"	0"	0"	0"	0"	0"	0"
24"	0"	0"	0"	0"	0"	0"	1"	
S	All	4-1/2"	4-1/2"	4-1/2"	4-1/2"	5"	7-1/4"	
X	<8"	4"	4"	4"	4"	4"	4"	
	≥8"	2-5/8"	2-5/8"	2-5/8"	2-5/8"	2-5/8"	2-5/8"	
J	<8"	2"	2"	2"	2"	2"	2"	
	≥8"	3-3/8"	3-3/8"	3-3/8"	3-3/8"	3-3/8"	3-3/8"	

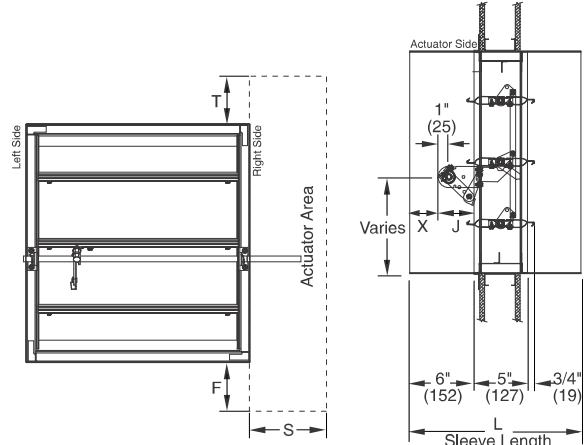

- NOTE:**
1. Sleeve length "L" = wall/floor thickness + 10" (254). Standard sleeve length "L" = 16" (406).
 2. Damper may be rotated 180° to position actuator area on the left side.
 3. The entire damper frame is not required to be installed within the wall, partition or floor. However, the closed plane of the damper blades must be inside the wall, partition or floor.
 4. Dimensions for FSNF24 apply to FSAFB24-SR and FSAFB24.
 5. Dimensions for FSLF apply to FSTF.
 6. Dimensions for ML4115/ML8115 apply to MS4209/MS8209.
 7. For dimensions on actuators not shown above, contact factory.

Airflow Performance Data

Pressure Loss vs. Velocity

Figure 5.3 — Ducted Inlet and Outlet

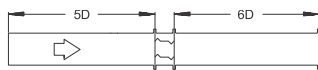
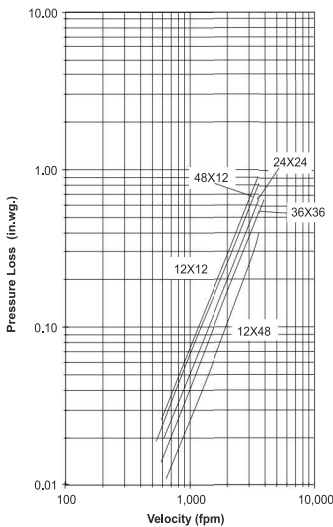

Ducted Inlet and Outlet

AMCA Figure 5.3 illustrates a fully ducted damper. This configuration represents the lowest pressure drop of the three test configurations because entrance and exit losses are minimized by straight duct runs upstream and downstream of the damper.

Figure 5.2 — Ducted Inlet

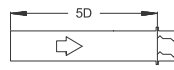
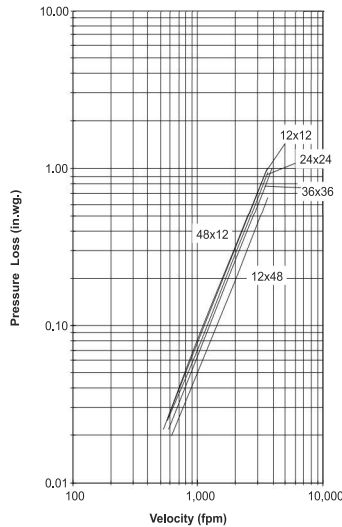

Ducted Inlet

AMCA Figure 5.2 illustrates a ducted damper exhausting air into an open area. This configuration has a lower pressure drop than Figure 5.5 because entrance losses are minimized by a straight duct run upstream of the damper.

Figure 5.5 Plenum Mount

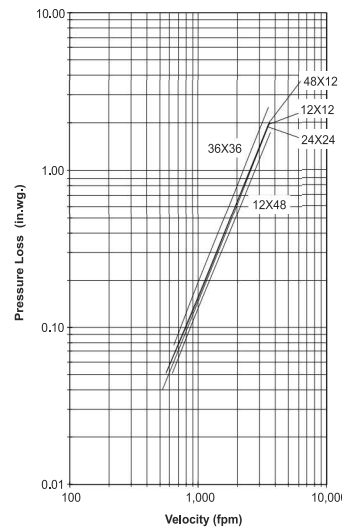

Plenum Mount

AMCA Figure 5.5 illustrates a plenum mounted damper. This configuration has the highest pressure drop because of extremely high entrance and exit losses due to the sudden changes of area in the system.



Air Performance

Pottorff certifies that the model FSD-151 shown herein is licensed to bear the AMCA seal. The ratings shown are based on tests and procedures performed in accordance with AMCA publication 511 and comply with the requirements of the AMCA Certified Ratings Program. The AMCA Certified Ratings Seal applies to air performance ratings only.

Pressure drop testing was performed in accordance with AMCA Standard 500-D using the three configurations shown. All data has been corrected to represent air density of 0.075 lb/ft. Actual pressure drop in any ducted HVAC system is a combination of many elements. This information, along with analysis of other system influences, should be used to estimate actual pressure losses for a damper installed in a given HVAC system.

Fire Dampers

Application

The VFD-10D-A fire damper employs curtain style blades for point-of-origin control of fire in static and dynamic HVAC systems. The VFD-10D-A is qualified to 4,000 ft/min (20.3 m/s) and 4 in.wg. (1.0 kPa) and may be installed in vertical walls or partitions, or horizontally in floors or assemblies with fire resistance ratings up to 2 hours.

Standard Construction

- Frame:** 22 gauge (0.85) galvanized steel.
- Blades:** 24 gauge (0.7) galvanized steel – curtain style.
- Fire Closure Device:** Fusible link.
- Fire Closure Temperature:** 165°F (75°C).
- Minimum Size:** 6" x 6" (152 x 152)
- Maximum Size:**
 - Single section: Vertical: 36" x 48" (914 x 1219)
 - Horizontal: 36" x 36" (914 x 914)
 - Multiple Section: Vertical: 72" x 120" (1829 x 3048)
 - Horizontal: 120" x 72" (3048 x 1829)
 - Horizontal: 36" x 36" (914 x 914)
 - Horizontal: 72" x 18" (1829 x 457)

Ratings

- UL 555 Fire Resistance Rating:** 1½ hour (vertical and horizontal)
- UL HNLJ.V-5:** Ventilation Duct Assemblies
- *** Maximum Dynamic Closure Velocity:** 4,000 fpm (20.3 m/s)
2,000 fpm (10.2 m/s)
- Maximum UL555S Rated Pressure:** 4 in.wg. (1.0 kPa)

Listings

- UL 555 listing:** R11767
- CSFM listing:** 3225-0368:101
- New York City MEA listing:** 295-98-E
- Meets NFPA Standards:** 90A, 92A, 92B and 101
- Meets Building Code Standards:** IBC, NBC, NFPA, SBC and UBC

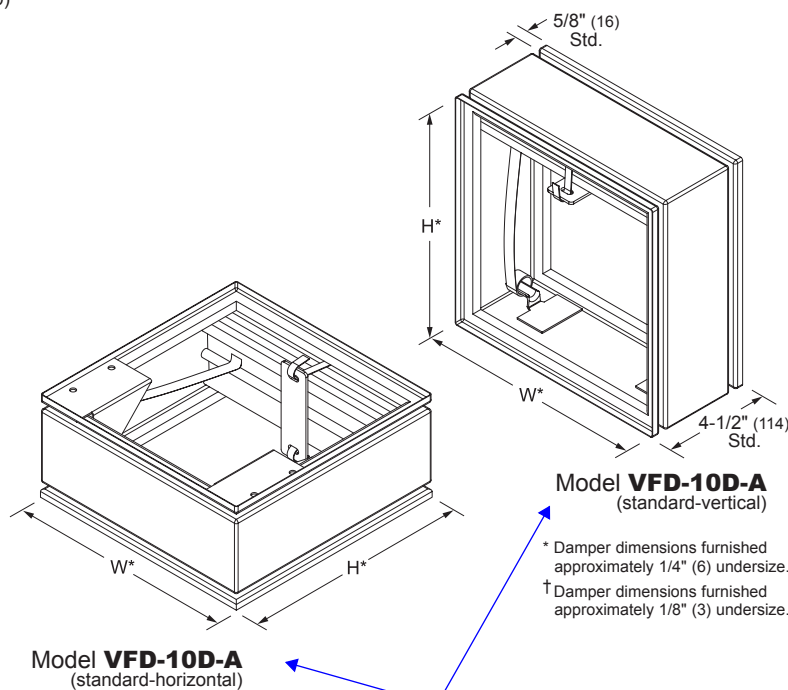

Model **VFD-10D-A**
(standard-vertical)

* Damper dimensions furnished approximately 1/4" (6) undersize.
 † Damper dimensions furnished approximately 1/8" (3) undersize.

Model **VFD-10D-A**
(standard-horizontal)

Contractor to confirm mounting

Curtain Dampers **VFD10DA** (1/3) May 2019

Blade Stack Dimensional Layout

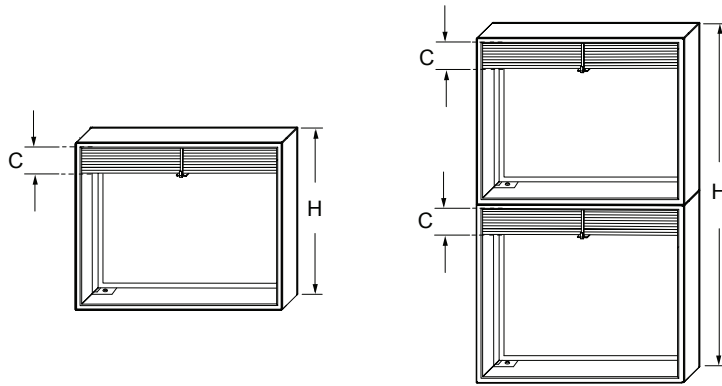

Framed Unit — No Sleeve
(Multiple section units supplied as individual dampers for field assembly)

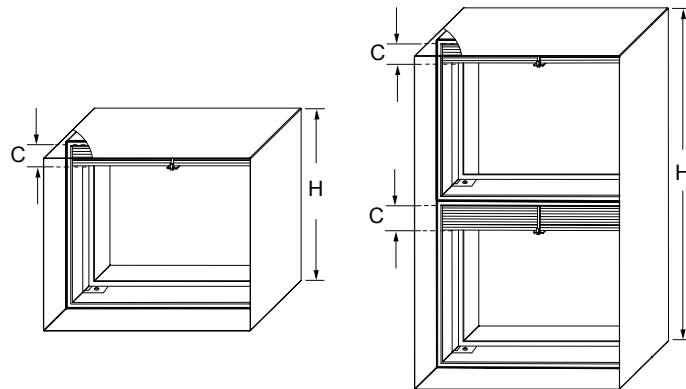

Sleeve Style S — Common Sleeve
(Multiple section units supplied as a single assembly)

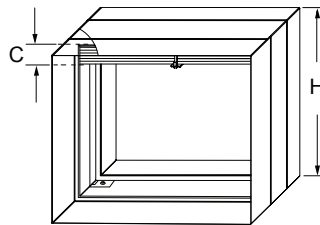

Sleeve Style IS — Integral Sleeve

Multiple section dampers shown as one wide by two high - two wide by one high similar.

Blade Stack Dimensional Data Sizing Chart

Nominal Duct Height 'H'	Damper Width		Nominal Duct Height 'H'	Damper Width	
	6" (152) - 36" (914)	37" (940) - 48" (1219)		49" (1245) - 72" (1829)	73" (1854) - 120" (3048)
	Blade Stack Height 'C'	Blade Stack Height 'C'		Blade Stack Height 'C'	Blade Stack Height 'C'
6" (152)	1-1/16" (27)	1-1/16" (27)	6" (152)	1-1/16" (27)	1-1/16" (27)
7" (178) - 9" (229)	1-3/16" (30)	1-3/16" (30)	7" (178) - 9" (229)	1-3/16" (30)	1-3/16" (30)
10" (254) - 12" (305)	1-7/16" (37)	1-7/16" (37)	10" (254) - 12" (305)	1-7/16" (37)	1-7/16" (37)
13" (330) - 14" (356)	1-9/16" (40)	1-9/16" (40)	13" (330) - 14" (356)	1-9/16" (40)	1-9/16" (40)
15" (381) - 17" (432)	1-13/16" (46)	1-13/16" (46)	15" (381) - 17" (432)	1-13/16" (46)	1-13/16" (46)
18" (457) - 19" (483)	1-15/16" (49)	1-15/16" (49)	18" (457) - 19" (483)	1-15/16" (49)	1-15/16" (49)
20" (508) - 22" (559)	2-3/16" (56)	2-3/16" (56)	20" (508) - 22" (559)	2-3/16" (56)	2-3/16" (56)
23" (584) - 24" (610)	2-5/16" (59)	2-5/16" (59)	23" (584) - 24" (610)	2-5/16" (59)	2-5/16" (59)
25" (635) - 27" (686)	2-9/16" (65)	2-9/16" (65)	25" (635) - 27" (686)	2-9/16" (65)	2-9/16" (65)
28" (711) - 29" (737)	2-11/16" (68)	2-11/16" (68)	28" (711) - 29" (737)	2-11/16" (68)	2-11/16" (68)
30" (762) - 32" (813)	2-15/16" (75)	2-15/16" (75)	30" (762) - 32" (813)	2-15/16" (75)	2-15/16" (75)
33" (838) - 34" (864)	3-1/16" (78)	3-1/16" (78)	33" (838) - 34" (864)	3-1/16" (78)	3-1/16" (78)
35" (889) - 36" (914)	3-5/16" (84)	3-5/16" (84)	35" (889) - 36" (914)	3-5/16" (84)	3-5/16" (84)
37" (940) - 39" (991)	3-5/16" (84)	3-5/16" (84)	37" (940) - 39" (991)	1-15/16" (49)	1-15/16" (49)
40" (1016) - 42" (1067)	3-11/16" (94)	3-11/16" (94)	40" (1016) - 42" (1067)	2-3/16" (56)	2-3/16" (56)
43" (1092) - 44" (1118)	3-13/16" (97)	3-13/16" (97)	46" (1168) - 49" (1245)	2-5/16" (59)	2-5/16" (59)
45" (1143) - 47" (1194)	4-1/16" (103)	4-1/16" (103)	50" (1270) - 55" (1397)	2-9/16" (65)	2-9/16" (65)
48" (1219)	4-3/16" (106)	4-3/16" (106)	56" (1422) - 59" (1499)	2-11/16" (68)	2-11/16" (68)
49" (1245) - 54" (1372)	2-9/16" (65)	2-9/16" (65)	60" (1524) - 65" (1651)	2-15/16" (75)	2-15/16" (75)
55" (1397) - 58" (1473)	2-11/16" (68)	2-11/16" (68)	66" (1676) - 72" (1829)	3-1/16" (78)	3-1/16" (78)
59" (1499) - 64" (1626)	2-15/16" (75)	2-15/16" (75)	73" (1854) - 74" (1880)	2-5/16" (59)	
65" (1651) - 68" (1727)	3-1/16" (78)	3-1/16" (78)	75" (1905) - 83" (2108)	2-9/16" (65)	
69" (1753) - 72" (1829)	3-5/16" (84)	3-5/16" (84)	84" (2134) - 89" (2291)	2-11/16" (68)	
73" (1854) - 74" (1880)	3-5/16" (84)	2-5/16" (59)	90" (2286) - 120" (3048)	2-15/16" (75)	
75" (1905) - 78" (1981)	3-7/16" (87)	2-9/16" (65)			
79" (2007) - 84" (2134)	3-11/16" (94)	2-9/16" (65)			
85" (2159) - 88" (2235)	3-13/16" (97)	2-11/16" (68)			
89" (2291) - 94" (2388)	4-1/16" (103)	2-11/16" (68)			
95" (2413) - 96" (2438)	4-3/16" (106)	2-15/16" (75)			
97" (2464) - 120" (3048)	2-15/16" (75)	2-15/16" (75)			

NOTES:

Dampers in the shaded area are for Vertical Mount only.

Dampers inside the Bold Outline will be manufactured in individual sections not exceeding 36" x 48".

Vertical dampers exceeding 72" x 48" or 36" x 96" will be manufactured in individual sections not exceeding 36" x 36".

POTTORFF®

model **VFD-10D-B**
 1½ hour • dynamic rated — fire damper
 curtain style blade

Application

The VFD-10D-B fire damper employs out of the airstream curtain style blades for point-of-origin control of fire in static and dynamic HVAC systems. The VFD-10D-B is qualified to 4,000 ft/min (20.4 m/s) and 4 in.wg. (1.0 kPa) and may be installed in vertical walls or partitions, or horizontally in floors or assemblies with fire resistance ratings up to 2 hours.

Standard Construction

Frame: 22 gauge (0.85) galvanized steel.

Blades: 24 gauge (0.7) galvanized steel – curtain style.

Fire Closure Device: Fusible link.

Fire Closure Temperature: 165°F (75°C).

Minimum Size: 6" x 4" (152 x 102)

Maximum Size: Single section: Vertical: 36" x 44" (914 x 1118)
 Horizontal: 36" x 33" (914 x 838)
 Multiple Section: Vertical: 120" x 69" (3048 x 1753)
 72" x 117" (1829 x 2972)
 Horizontal: 36" x 34" (914 x 864)
 72" x 16" (1829 x 406)

Ratings

UL 555 Fire Resistance Rating: 1½ hour (vertical and horizontal)

UL HNLJ.V-5: Ventilation Duct Assemblies

*** **Maximum Dynamic Closure Velocity:** 4,000 fpm (20.3 m/s)
 2,000 fpm (10.2 m/s)

Maximum UL555S Rated Pressure: 4 in.wg. (1.0 kPa)

Listings

UL 555 listing: R11767

CSFM listing: 3225-0368:101

New York City MEA listing: 295-98-E

Meets NFPA Standards: 90A, 92A, 92B and 101

Meets Building Code Standards: IBC, NBC, NFPA, SBC and UBC

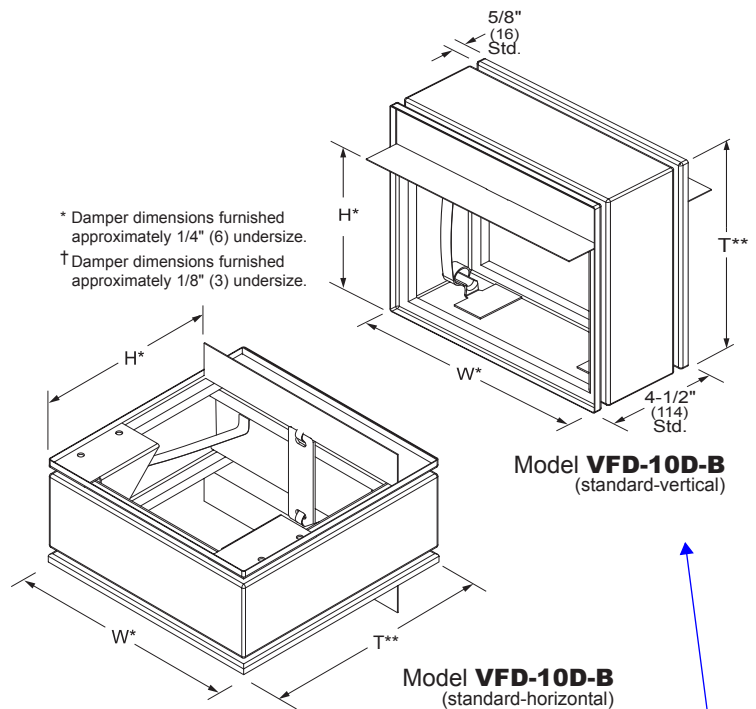

Contractor to confirm mounting

Blade Stack Dimensional Layout

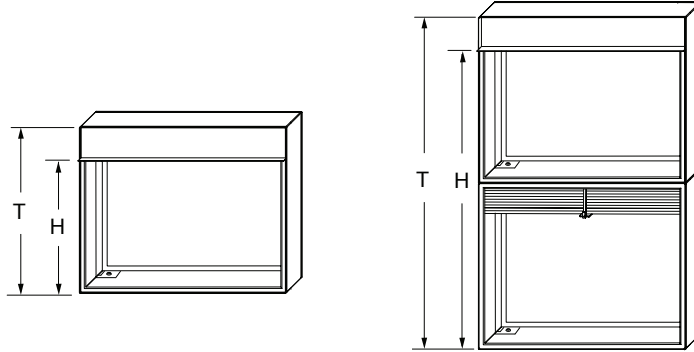

Framed Unit — No Sleeve
(Multiple section units supplied as individual dampers for field assembly)

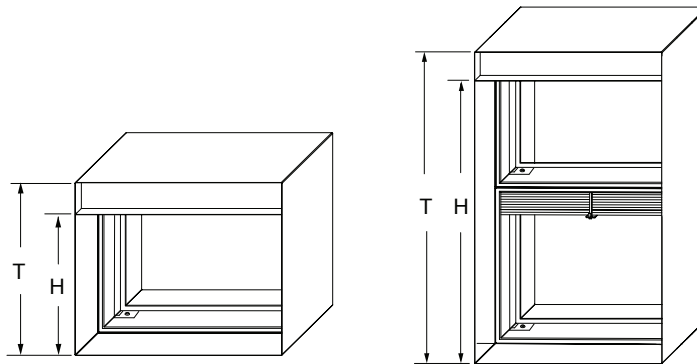

Sleeve Style S — Common Sleeve
(Multiple section units supplied as a single assembly)

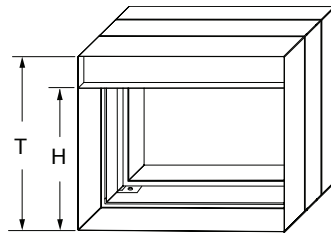

Sleeve Style IS — Integral Sleeve

Multiple section dampers shown as one wide by two high - two wide by one high similar.

Blade Stack Dimensional Data Sizing Chart

Nominal Duct Height 'H'	Damper Width		
	6" (152) - 36" (914)	37" (940) - 72" (1829)	73" (1854) - 120" (3048)
	Damper Height 'T'	Damper Height 'T'	Damper Height 'T'
4" (102)	6" (152)	6" (152)	6" (152)
5" (127)	7" (178)	7" (178)	7" (178)
6" (152)	8" (203)	8" (203)	8" (203)
7" (178)	9" (229)	9" (229)	9" (229)
8" (203)	10" (254)	10" (254)	10" (254)
9" (229)	11" (279)	11" (279)	11" (279)
10" (254)	12" (305)	12" (305)	12" (305)
11" (279)	13" (330)	13" (330)	13" (330)
12" (305)	14" (356)	14" (356)	14" (356)
13" (330)	15" (381)	15" (381)	15" (381)
14" (356)	16" (406)	16" (406)	16" (406)
15" (381)	17" (432)	17" (432)	17" (432)
16" (406)	18" (457)	18" (457)	18" (457)
17" (432)	19" (483)	19" (483)	19" (483)
18" (457)	20" (508)	20" (508)	20" (508)
19" (483)	21" (533)	21" (533)	21" (533)
20" (508)	22" (559)	22" (559)	22" (559)
21" (533)	23" (584)	23" (584)	23" (584)
22" (559)	24" (610)	24" (610)	24" (610)
23" (584)	26" (660)	26" (660)	26" (660)
24" (610)	27" (686)	27" (686)	27" (686)
25" (635)	28" (711)	28" (711)	28" (711)
26" (660)	29" (737)	29" (737)	29" (737)
27" (686)	30" (762)	30" (762)	30" (762)
28" (711)	31" (787)	31" (787)	31" (787)
29" (737)	32" (813)	32" (813)	32" (813)
30" (762)	33" (838)	33" (838)	33" (838)
31" (787)	34" (864)	34" (864)	34" (864)
32" (813)	35" (889)	35" (889)	35" (889)
33" (838)	36" (914)	36" (914)	36" (914)
34" (864)	37" (940)	37" (940)	36" (914)
35" (889)	38" (965)	38" (965)	37" (940)
36" (914)	39" (991)	39" (991)	38" (965)
37" (940)	41" (1041)	41" (1041)	39" (991)
38" (965)	42" (1067)	42" (1067)	40" (1016)
39" (991)	43" (1092)	43" (1092)	41" (1041)
40" (1016)	44" (1118)	44" (1118)	42" (1067)
41" (1041)	45" (1143)	45" (1143)	43" (1092)
42" (1067)	46" (1168)	46" (1168)	44" (1118)
43" (1092)	47" (1194)	47" (1194)	45" (1143)
44" (1118)	48" (1219)	48" (1219)	46" (1168)
45" (1143)	47" (1194)	47" (1194)	47" (1194)
46" (1168)	48" (1219)	48" (1219)	48" (1219)
47" (1194)	50" (1270)	50" (1270)	50" (1270)
48" (1219)	51" (1295)	51" (1295)	51" (1295)
49" (1245)	52" (1321)	52" (1321)	52" (1321)
50" (1270)	53" (1346)	53" (1346)	53" (1346)
51" (1295)	54" (1372)	54" (1372)	54" (1372)
52" (1321)	55" (1397)	55" (1397)	55" (1397)
53" (1346)	56" (1422)	56" (1422)	56" (1422)
54" (1372)	57" (1448)	57" (1448)	57" (1448)
55" (1397)	58" (1473)	58" (1473)	58" (1473)
56" (1422)	59" (1499)	59" (1499)	59" (1499)
57" (1448)	60" (1524)	60" (1524)	60" (1524)
58" (1473)	61" (1549)	61" (1549)	61" (1549)
59" (1499)	62" (1575)	62" (1575)	62" (1575)
60" (1524)	63" (1600)	63" (1600)	63" (1600)
61" (1549)	64" (1626)	64" (1626)	64" (1626)
62" (1575)	65" (1651)	65" (1651)	65" (1651)
63" (1600)	66" (1676)	66" (1676)	66" (1676)
64" (1626)	67" (1702)	67" (1702)	67" (1702)
65" (1651)	68" (1727)	68" (1727)	68" (1727)
66" (1676)	69" (1753)	69" (1753)	69" (1753)
67" (1702)	70" (1778)	70" (1778)	70" (1778)
68" (1727)	71" (1803)	71" (1803)	71" (1803)
69" (1753)	72" (1829)	72" (1829)	72" (1829)

Nominal Duct Height 'H'	Damper Width	
	6" (152) - 36" (914)	37" (940) - 72" (1829)
	Damper Height 'T'	Damper Height 'T'
70" (1778)	73" (1854)	72" (1829)
71" (1803)	74" (1880)	74" (1880)
72" (1829)	75" (1905)	75" (1905)
73" (1854)	76" (1930)	76" (1930)
74" (1880)	77" (1956)	77" (1956)
75" (1905)	78" (1981)	78" (1981)
76" (1930)	80" (2032)	79" (2007)
77" (1956)	81" (2057)	80" (2032)
78" (1981)	82" (2083)	81" (2057)
79" (2007)	83" (2108)	82" (2083)
80" (2032)	84" (2134)	83" (2108)
81" (2057)	85" (2159)	84" (2134)
82" (2083)	86" (2184)	85" (2159)
83" (2108)	87" (2210)	86" (2184)
84" (2134)	88" (2235)	87" (2210)
85" (2159)	89" (2261)	88" (2235)
86" (2184)	90" (2286)	89" (2261)
87" (2210)	91" (2311)	90" (2286)
88" (2235)	92" (2337)	91" (2311)
89" (2261)	93" (2362)	92" (2337)
90" (2286)	94" (2388)	93" (2362)
91" (2311)	95" (2413)	94" (2388)
92" (2337)	96" (2438)	95" (2413)
93" (2362)	96" (2438)	96" (2438)
94" (2388)	97" (2464)	97" (2464)
95" (2413)	98" (2489)	98" (2489)
96" (2438)	99" (2515)	99" (2515)
97" (2464)	100" (2540)	100" (2540)
98" (2489)	101" (2565)	101" (2565)
99" (2515)	102" (2591)	102" (2591)
100" (2540)	103" (2616)	103" (2616)
101" (2565)	104" (2642)	104" (2642)
102" (2591)	105" (2667)	105" (2667)
103" (2616)	106" (2692)	106" (2692)
104" (2642)	107" (2718)	107" (2718)
105" (2667)	108" (2743)	108" (2743)
106" (2692)	109" (2769)	109" (2769)
107" (2718)	110" (2794)	110" (2794)
108" (2743)	111" (2819)	111" (2819)
109" (2769)	112" (2845)	112" (2845)
110" (2794)	113" (2870)	113" (2870)
111" (2819)	114" (2896)	114" (2896)
112" (2845)	115" (2921)	115" (2921)
113" (2870)	116" (2946)	116" (2946)
114" (2896)	117" (2972)	117" (2972)
115" (2921)	118" (2997)	118" (2997)
116" (2946)	119" (3023)	119" (3023)
117" (2972)	120" (3048)	120" (3048)

Curtain Dampers VFD10DB (3/3) July 2019

NOTES:

Dampers in the shaded area are for Vertical Mount only.
 Dampers inside the Bold Outline will be manufactured in individual sections not exceeding 36" x 48".
 Vertical dampers exceeding 72" x 48" or 36" x 96" will be manufactured in individual sections not exceeding 36" x 36".

POTTORFF®

model **VFD-10D-C**
 1½ hour • dynamic rated — fire damper
 curtain style blade

Application

The VFD-10D-C fire damper employs out of the airstream frame and curtain style blades for point-of-origin control of fire in static and dynamic HVAC systems. The VFD-10D-C is qualified to 4,000 ft/min (20.4 m/s) and 4 in.wg. (1.0 kPa) and may be installed in vertical walls or partitions, or horizontally in floors or assemblies with fire resistance ratings up to 2 hours.

Standard Construction

- Frame:** 22 gauge (0.85) galvanized steel.
- Blades:** 24 gauge (0.7) galvanized steel – curtain style.
- Fire Closure Device:** Fusible link.
- Fire Closure Temperature:** 165°F (75°C).
- Minimum Size:** 4" × 3" (102 × 76)
- Maximum Size:**
 - Single section: Vertical: 34" × 43" (864 × 1092)
 - Horizontal: 34" × 32" (864 × 813)
 - Multiple Section: Vertical: 118" × 68" (2997 × 1727)
 - Horizontal: 70" × 116" (1778 × 2976)
 - 34" × 33" (864 × 838)
 - 70" × 15" (1778 × 381)

Ratings

- UL 555 Fire Resistance Rating:** 1½ hour (vertical and horizontal)
- UL HNLJ.V-5:** Ventilation Duct Assemblies
- *** **Maximum Dynamic Closure Velocity:** 4,000 fpm (20.3 m/s)
2,000 fpm (10.2 m/s)
- Maximum UL555S Rated Pressure:** 4 in.wg. (1.0 kPa)

Listings

- UL 555 listing:** R111767
- CSFM listing:** 3225-0368:101
- New York City MEA listing:** 295-98-E
- Meets NFPA Standards:** 90A, 92A, 92B and 101
- Meets Building Code Standards:** IBC, NBC, NFPA, SBC and UBC

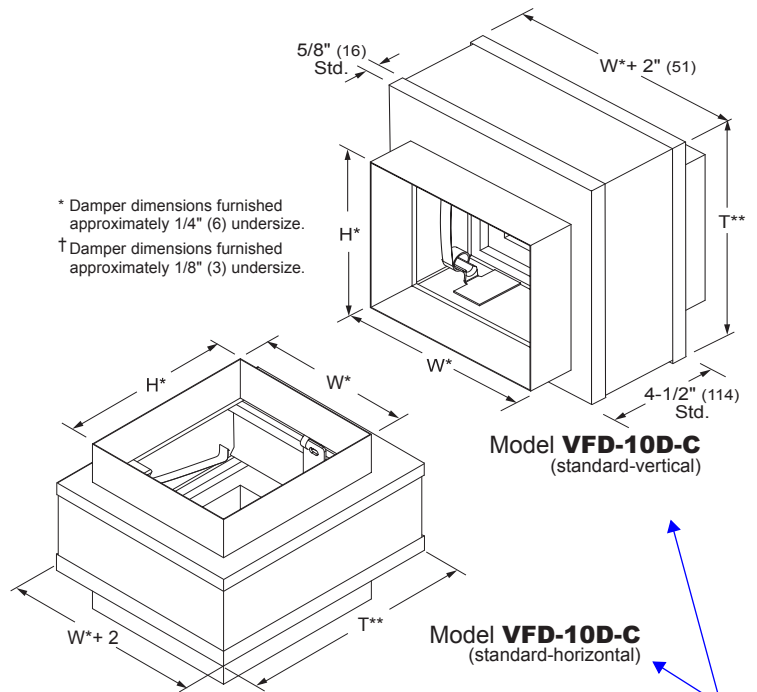

Round Transitions

(Standard with D=W=H. Available with D<W and H)

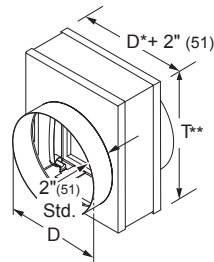

Style CR (optional)

Curtain Dampers VFD-10DC (1/3) July 2019

Blade Stack Dimensional Layout

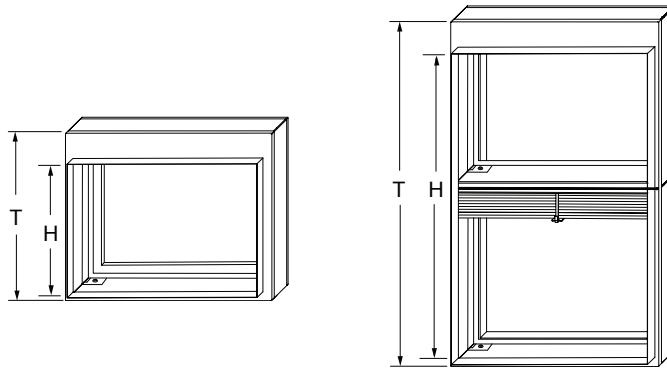

Framed Unit — No Sleeve
(Multiple section units supplied as a single assembly)

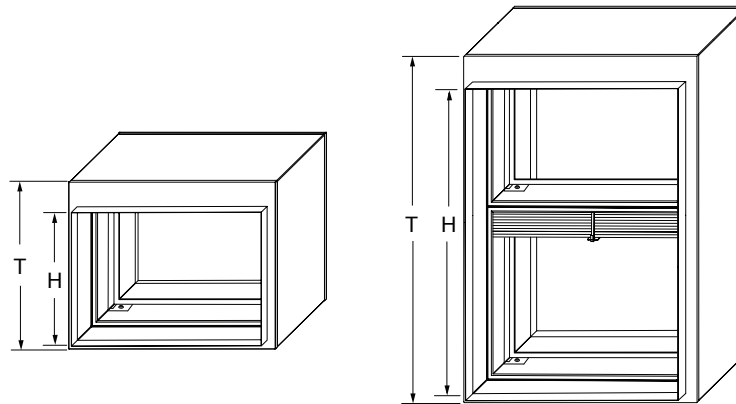

Sleeve Style S — Common Sleeve
(Multiple section units supplied as a single assembly)

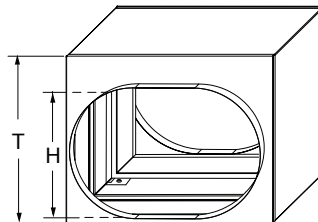

Sleeve Style IS — Integral Sleeve

Multiple section dampers shown as two wide by one high - one wide by two high similar.

Blade Stack Dimensional Data Sizing Chart

Nominal Duct Height 'H'	Nominal Duct Width		
	4" (102) - 34" (864)	35" (889) - 70" (1778)	71" (1803) - 118" (2997)
	Damper Height 'T'	Damper Height 'T'	Damper Height 'T'
3" (76)	6" (152)	6" (152)	6" (152)
4" (102)	7" (178)	7" (178)	7" (178)
5" (127)	8" (203)	8" (203)	8" (203)
6" (152)	9" (229)	9" (229)	9" (229)
7" (178)	10" (254)	10" (254)	10" (254)
8" (203)	11" (279)	11" (279)	11" (279)
9" (229)	12" (305)	12" (305)	12" (305)
10" (254)	13" (330)	13" (330)	13" (330)
11" (279)	14" (356)	14" (356)	14" (356)
12" (305)	15" (381)	15" (381)	15" (381)
13" (330)	16" (406)	16" (406)	16" (406)
14" (356)	17" (432)	17" (432)	17" (432)
15" (381)	18" (457)	18" (457)	18" (457)
16" (406)	19" (483)	19" (483)	19" (483)
17" (432)	20" (508)	20" (508)	20" (508)
18" (457)	21" (533)	21" (533)	21" (533)
19" (483)	22" (559)	22" (559)	22" (559)
20" (508)	23" (584)	23" (584)	23" (584)
21" (533)	24" (610)	24" (610)	24" (610)
22" (559)	26" (660)	26" (660)	26" (660)
23" (584)	27" (686)	27" (686)	27" (686)
24" (610)	28" (711)	28" (711)	28" (711)
25" (635)	29" (737)	29" (737)	29" (737)
26" (660)	30" (762)	30" (762)	30" (762)
27" (686)	31" (787)	31" (787)	31" (787)
28" (711)	32" (813)	32" (813)	32" (813)
29" (737)	33" (838)	33" (838)	33" (838)
30" (762)	34" (864)	34" (864)	34" (864)
31" (787)	35" (889)	35" (889)	35" (889)
32" (813)	36" (914)	36" (914)	36" (914)
33" (838)	37" (940)	37" (940)	36" (914)
34" (864)	38" (965)	38" (965)	37" (940)
35" (889)	39" (991)	39" (991)	38" (965)
36" (914)	41" (1041)	41" (1041)	39" (991)
37" (940)	42" (1067)	42" (1067)	40" (1016)
38" (965)	43" (1092)	43" (1092)	41" (1041)
39" (991)	44" (1118)	44" (1118)	42" (1067)
40" (1016)	45" (1143)	45" (1143)	43" (1092)
41" (1041)	46" (1168)	46" (1168)	44" (1118)
42" (1067)	47" (1194)	47" (1194)	45" (1143)
43" (1092)	48" (1219)	48" (1219)	46" (1168)
44" (1118)	47" (1194)	47" (1194)	47" (1194)
45" (1143)	48" (1219)	48" (1219)	48" (1219)
46" (1168)	50" (1270)	50" (1270)	50" (1270)
47" (1194)	51" (1295)	51" (1295)	51" (1295)
48" (1219)	52" (1321)	52" (1321)	52" (1321)
49" (1245)	53" (1346)	53" (1346)	53" (1346)
50" (1270)	54" (1372)	54" (1372)	54" (1372)
51" (1295)	55" (1397)	55" (1397)	55" (1397)
52" (1321)	56" (1422)	56" (1422)	56" (1422)
53" (1346)	57" (1448)	57" (1448)	57" (1448)
54" (1372)	58" (1473)	58" (1473)	58" (1473)
55" (1397)	59" (1499)	59" (1499)	59" (1499)
56" (1422)	60" (1524)	60" (1524)	60" (1524)
57" (1448)	61" (1549)	61" (1549)	61" (1549)
58" (1473)	62" (1575)	62" (1575)	62" (1575)
59" (1499)	63" (1600)	63" (1600)	63" (1600)
60" (1524)	64" (1626)	64" (1626)	64" (1626)
61" (1549)	65" (1651)	65" (1651)	65" (1651)
62" (1575)	66" (1676)	66" (1676)	66" (1676)
63" (1600)	67" (1702)	67" (1702)	67" (1702)
64" (1626)	68" (1727)	68" (1727)	68" (1727)
65" (1651)	69" (1753)	69" (1753)	69" (1753)
66" (1676)	70" (1778)	70" (1778)	70" (1778)
67" (1702)	71" (1803)	71" (1803)	71" (1803)
68" (1727)	72" (1829)	72" (1829)	72" (1829)

Nominal Duct Height 'H'	Nominal Duct Width	
	4" (102) - 34" (864)	35" (889) - 70" (1778)
	Damper Height 'T'	Damper Height 'T'
69" (1753)	73" (1854)	72" (1829)
70" (1778)	74" (1880)	74" (1880)
71" (1803)	75" (1905)	75" (1905)
72" (1829)	76" (1930)	76" (1930)
73" (1854)	77" (1956)	77" (1956)
74" (1880)	78" (1981)	78" (1981)
75" (1905)	80" (2032)	79" (2007)
76" (1930)	81" (2057)	80" (2032)
77" (1956)	82" (2083)	81" (2057)
78" (1981)	83" (2108)	82" (2083)
79" (2007)	84" (2134)	83" (2108)
80" (2032)	85" (2159)	84" (2134)
81" (2057)	86" (2184)	85" (2159)
82" (2083)	87" (2210)	86" (2184)
83" (2108)	88" (2235)	87" (2210)
84" (2134)	89" (2261)	88" (2235)
85" (2159)	90" (2286)	89" (2261)
86" (2184)	91" (2311)	90" (2286)
87" (2210)	92" (2337)	91" (2311)
88" (2235)	93" (2362)	92" (2337)
89" (2261)	94" (2388)	93" (2362)
90" (2286)	95" (2413)	94" (2388)
91" (2311)	96" (2438)	95" (2413)
92" (2337)	96" (2438)	96" (2438)
93" (2362)	97" (2464)	97" (2464)
94" (2388)	98" (2489)	98" (2489)
95" (2413)	99" (2515)	99" (2515)
96" (2438)	100" (2540)	100" (2540)
97" (2464)	101" (2565)	101" (2565)
98" (2489)	102" (2591)	102" (2591)
99" (2515)	103" (2616)	103" (2616)
100" (2540)	104" (2642)	104" (2642)
101" (2565)	105" (2667)	105" (2667)
102" (2591)	106" (2692)	106" (2692)
103" (2616)	107" (2718)	107" (2718)
104" (2642)	108" (2743)	108" (2743)
105" (2667)	109" (2769)	109" (2769)
106" (2692)	110" (2794)	110" (2794)
107" (2718)	111" (2819)	111" (2819)
108" (2743)	112" (2845)	112" (2845)
109" (2769)	113" (2870)	113" (2870)
110" (2794)	114" (2896)	114" (2896)
111" (2819)	115" (2921)	115" (2921)
112" (2845)	116" (2946)	116" (2946)
113" (2870)	117" (2972)	117" (2972)
114" (2896)	118" (2997)	118" (2997)
115" (2921)	119" (3023)	119" (3023)
116" (2946)	120" (3048)	120" (3048)

Note:

Dampers in the shaded area are for Vertical Mount only.
 Dampers inside the Bold Outline will be manufactured in individual sections not exceeding 36" x 48".
 Vertical dampers exceeding 72" x 48" or 36" x 96" will be manufactured in individual sections not exceeding 36" x 36".

Curtain Dampers VFD10DC (3/3), July 2019

Installation
Operation
Maintenance

The following installation details apply to models **FSD-141, FSD-142, FSD-143, FSD-151, FSD-151V, FSD-152, FSD-152V, FSD-171 and FSD-172**

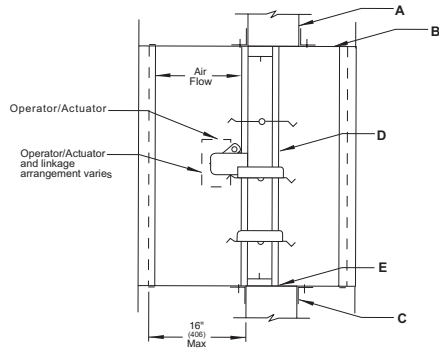

Vertical Mount

All dimensions shown in () are in millimeters. Illustration depicts damper installed vertical right side up. Damper may also be installed upside down.

Illustrations show triple-V bladed (140/170 type), steel airfoil blade (150 type) similar.

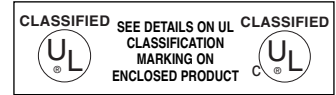

- A.** Concrete or masonry fire partition shown. See Wood Stud and/or Steel Stud Framing for Fire Dampers In Drywall and/or Cavity Shaftwall Partitions Supplemental Installation Instructions for further vertical mount installation details. The opening shall be a minimum of ¼" (6) with a maximum of ¾" (19) larger than the overall damper and sleeve assembly size. When openings are larger than ¾" (19), but less than 6" (152) the mounting angles must be a minimum of 16 gauge (1.5) and must be tall enough to overlap the opening by a minimum of 1" (25). Damper must be installed with leading edge of closed blade within the partition.
- B.** For rigid type duct connections, the sleeve shall be a minimum of 16 gauge (1.5) for dampers up to 36" wide by 24" high (914 x 610) and 14 gauge (1.9) for larger units. When lighter gauge sleeves are used, one or more of commonly used breakaway style connections are required. Refer to Sleeve Termination Supplemental Installation Instructions for further details. In no case will the sleeve gauge be less than the duct gauge to which it is connected. Damper sleeve shall not extend more than 16" (406) beyond the rated partition on the actuator side. The opposite side extension shall be a maximum of 6" (152) unless an access door is installed in the sleeve which then permits the extension to be a maximum of 16" (406).
- C.** Mounting angles shall be a minimum of ¾" x 1-½" tall x 20 gauge (19 x 38 x 1.0). For opening sizes ≤80" wide (2032), 96" tall (2438) and not exceeding 26.67 square feet (2.48 square meters) mounting angles are required on only one side of the partition and must be attached to the sleeve and the partition. For larger openings (or optional on smaller openings) 1-½" x 1-½" x 16 gauge (38 x 38 x 1.5) mounting angles are required on both sides of the partition and must be attached to the sleeve only. Attachment to the sleeve shall be with a minimum of #10 (M5) screws or bolts, ⅜" (4.8) diameter steel rivets, Quick-Lock joints, or welds at 12" (305) o.c. maximum. Attachment to the partition/opening shall be with minimum #10 (M5) fasteners with a minimum length as follows: For metal studs and the angles under the drywall, the fasteners must be a minimum of ½" (12.7) long. For metal studs and the angles over the drywall the fastener must be a minimum of ½" (12.7) longer than the thickness of the drywall, i.e. if the partition has one layer of ⅝" (15.9) drywall on the attachment side, the screws must be ½" + ⅝" = 1⅛" (12.7 + 15.9 = 28.6) long. For wood stud openings, the minimum length is 1-½" (38) longer than the thickness of the drywall on the attachment side. For concrete or masonry openings, the anchors must be a minimum of #10 (M5) fasteners: screws, bolts or self-tapping masonry screws. Fasteners in the partition should be spaced at 12" (305) o.c. maximum. There must be a minimum of two connections per side on all four sides. A minimum of ¾" x 20 gauge (19 x 1) flange termination may be used in lieu of mounting angles. Refer to Sleeve Termination Supplemental Installation Instructions and Framing for Fire Dampers for further details. Ensure that the attachment device does not interfere with the operation of the damper and the free movement of the damper blades.

Note: If optional sealing between the mounting angle (or flange) leg and the surface of the partition, wall, or floor and/or between the mounting angle leg and the surface of the damper sleeve is required, any of the following sealants may be used: Dow Corning 700 or 732 or DOWSIL 700 or 732 or GE RTV 108 or SCS 1201 RTV These sealants must be applied such that they do not intrude into the annular space between the outside surface of the damper sleeve and the opening of the partition, wall or floor into which the damper/sleeve is installed. The annular space between damper sleeve and wall opening must not be filled with firestop materials such as fill, void, or cavity materials.

- D.** When joining multiple sections or fastening the damper to the sleeve, the damper shall be fastened with ⅜" (4.8) diameter steel rivets, Quick-Lock Joints, welds or #10 (M5) bolts or sheet metal screws at 8" (203) o.c. maximum. There must be a minimum of two connections per side, top and bottom. For vertical installations >108" wide x 96" high (2743 x 2438), a minimum 14 gauge x 5" wide (1.9 x 127) supplemental steel mullion is required. The mullion must be the same length as the opening/duct height. The mullion must be installed between the damper frames running parallel to the opening/duct height located at the center of the assembly. Supplemental support mullions should be attached to the damper frames using any of the same fasteners indicated previously in this section.
- E.** A continuous bead of Dow Corning 700 or 732 or DOWSIL 700 or 732 or GE RTV 108 or SCS 1201 RTV silicone rubber sealant shall be applied between the damper and the sleeve and between sections of a multiple damper assembly. Sealant is only required on one side of the damper.
- F.** Fire/Leakage rated dampers and qualified operators are tested together by Underwriters Laboratories and are factory installed to qualify for standard damper/operator warranties. Damper operator/actuator must be tested prior to system start-up to ensure proper operation. Before applying power to the operator/actuator, the power must be verified.

DUCT SIZES	GALVANIZED STEEL				STAINLESS
	FSD-141, 142, 143	FSD-151, 152	FSD-151V, 152V	FSD-171, 172	FSD-141, 142, 143
Maximum Single Section	36" x 48" (914 x 1219)	32" x 48" (813 x 1219)	48" x 32" (1219 x 813)	24" x 24" (610 x 610)	36" x 48" (914 x 1219)
Maximum Multiple Section	144" x 96" (3658 x 2438)	144" x 96" (3658 x 2438)	48" x 64" (1219 x 1626)	N/A	72" x 48" or 36" x 96" (1829 x 1219 or 914 x 2438)

The above information for dampers installed in a vertical fire separation pertains to those where the damper blades are horizontal. However, as an exception, if the dampers are Model FSD-141 and are 6" (152) wide by 6" (152) high, they may be installed with the blades in a vertical orientation. All other installation details are as outlined above except that the mounting angle on the top of the damper sleeve needs only to be a minimum of ¾" (19) tall.

Information is subject to change without notice or obligation.

NOTE: Dimensions in parentheses () are millimeters.

The following installation details apply to models **CFS-171, CFS-172, FSD-141, FSD-142, FSD-143, FSD-151, FSD-152, FSD-171 and FSD-172**

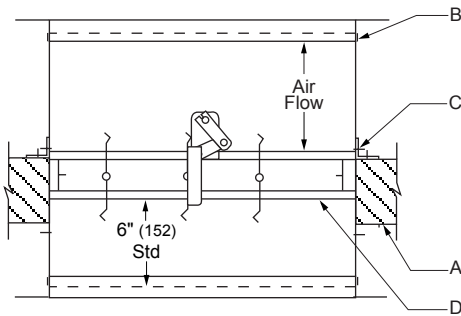

**Horizontal Mount
(Single Side Mounting Angle)**

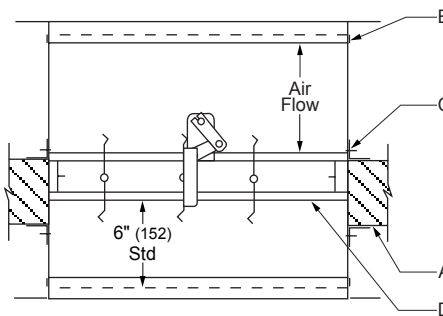

**Horizontal Mount
(2-sided Mounting Angles)**

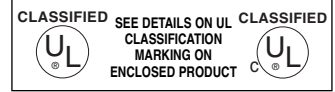

Illustration depicts damper installed from the top down with the actuator above the floor line. Damper may also be installed from the bottom up with the actuator below the floor line. Illustrations show triple-V bladed (140/170 type), steel airfoil blade (150 type) similar.



- A. Concrete or masonry fire partition shown. The opening shall be a minimum of ¼" (6) with a maximum of ¾" (19) larger than the overall damper and sleeve assembly size. When openings are larger than ¾" (19), but less than or equal to 6" (152) the mounting angles must be a minimum of 16 gauge (1.5) and must be wide enough to overlap the opening by a minimum of 1" (25). The damper must be installed with leading edge of closed blade within the partition.
- B. For rigid type duct connections, the sleeve shall be a minimum of 16 gauge (1.5) for dampers up to 36" wide by 24" high (914 × 610) and a minimum of 14 gauge (1.9) for larger units. When lighter gauge sleeves are used, one or more of commonly used breakaway style connections are required. Refer to Sleeve Termination Supplemental Installation Instructions for further details. In no case will the sleeve gauge be less than the duct gauge to which it is connected. The damper sleeve shall not extend more than 16" (406) beyond the rated partition on the actuator side. The opposite side extension shall be a maximum of 6" (152) unless an access door is installed in the sleeve which then permits the extension to be a maximum of 16" (406).
- C. Mounting angles shall be a minimum 1-½" × 1-½" × 16 gauge (38 × 38 × 1.5). Mounting angles are only required on the top side of the opening and must be attached to the sleeve at 6" (152) o.c. maximum, to the partition at 24" (610) o.c. maximum. There must be a minimum of two fasteners per side to both the sleeve and partition on all four sides. Alternately, mounting angles may be installed on both sides of the partition and must be attached only to the sleeve at 12" (305) o.c. maximum, with a minimum of two connections per side on all four sides. Attachment to the sleeve shall be with a minimum of #10 (M5) screws or bolts, ⅜" (4.8) diameter steel rivets, Quick-Lock joints, or welds. Attachment to the partition shall be with a minimum of #10 (M5) steel fasteners: anchors, bolts, or self-tapping masonry screws. A minimum ¾" × 20 gauge (19 × 1) flange termination may be used in lieu of mounting angles. Ensure that the attachment device does not interfere with the operation of the damper and the free movement of the damper blades.

Note: If optional sealing between the mounting angle (or flange) leg and the surface of the partition, or floor and/or between the mounting angle leg and the surface of the damper sleeve is required, any of the following sealants may be used: Dow Corning 700 or 732 or DOWSIL 700 or 732 or GE RTV 108 or SCS 1201 RTV. These sealants must be applied such that they do not intrude into the annular space between the outside surface of the damper sleeve and the opening of the partition, or floor into which the damper/sleeve is installed. The annular space between damper sleeve and opening must not be filled with firestop materials such as fill, void, or cavity materials.

- D. When joining multiple sections or fastening the damper to the sleeve, the damper shall be fastened with minimum ⅜" (4.8) diameter steel rivets, Quick-Lock Joints, welds or #10 (M5) bolts or sheet metal screws at 8" (203) o.c. maximum. There must be a minimum of two connections per side, top and bottom. For FSD-151 and 152 installations more than one damper high and three dampers wide, a minimum 14 gauge × 5" (1.9 × 127) supplemental steel mullion is required. The mullion should be the same length as the opening/duct height and must be installed between the damper frames running parallel to the opening/duct height, at the center of the assembly. Support mullions should be attached to the damper frames using the same fasteners indicated previously in this section.
- E. A continuous bead of Dow Corning 700 or 732 or DOWSIL 700 or 732 or GE RTV 108 or SCS 1201 RTV silicone rubber sealant shall be applied between the damper and the sleeve and between sections of a multiple damper assembly. Sealant is only required on one side of the damper.
- F. Fire/Leakage rated dampers and qualified operators are tested together by Underwriters Laboratories and are factory installed to qualify for standard damper/operator warranties. Damper operator/actuator must be tested prior to system start-up to ensure proper operation. Before applying power to the operator/actuator, the power must be verified.

DUCT SIZES	GALVANIZED STEEL				STAINLESS STEEL
	FSD-141, 142, 143	FSD-151, 152	FSD-171, 172	CFS-171, 172	FSD-141, 142, 143
Maximum Single Section	36" x 48" (914 x 1219)	32" x 48" (813 x 1219)	24" x 24" (610 x 610)	12" x 12" (305 x 305)	36" x 48" (914 x 1219)
Maximum Multiple Section	108" x 48" (2743 x 1219)	144" x 96" (3658 x 2438)	N/A	N/A	72" x 48" or 36" x 96" (1829 x 1219 or 914 x 2438)

*Individually sleeved dampers can be installed in partitions wider than the maximum U.L. multiple section size using the Support Mullion for Oversized Floor Openings. See Support Mullion for Oversized Floor Openings Installation Instructions for further details.

Information is subject to change without notice or obligation.

NOTE: Dimensions in parentheses () are millimeters.

Maintenance

Dampers do not typically require maintenance provided they are kept clean and dry. All moving parts are self-lubricating and additional lubrication is not required. If additional lubrication of axle bearings, jackshaft bearings or jamb seals is desired, use a silicone or dry graphite lubricant. **Do not use petroleum-based lubricants or other lubricants that attract contaminants and collect dust.**

Regular inspection and maintenance is essential to ensure that smoke-control systems will perform as intended during emergencies. Dampers shall be cycled and tested in accordance with all applicable NFPA specifications and local codes.

CAUTION - Power must be applied to the damper actuator to open the damper. **Do not manually position damper blades.** Disconnecting actuator linkage, loosening actuator set screws, disconnecting damper linkage or jack shafting may void the product warranty and invalidate UL ratings.

Operational Testing

NFPA specifications do not require heat to be applied to a damper's thermostat for operational testing. Electric or pneumatic actuated dampers are required to be tested by removing electrical or pneumatic power from the actuator to close the damper. The damper must reopen once electric or pneumatic power is restored. **Using uncontrolled heat to operate the thermostat may damage the damper and void all warranties.**

Position Indicator Switch Testing (if applicable)

- *Open Damper Indicator Switch* - Apply power to open damper and confirm damper-open indicator light is on.
- *Closed Damper Indicator Switch* - Disconnect power to close damper and confirm damper-closed indicator light is on.
- *Intermediate or 'Fault' Indication* (if applicable) - While damper is cycling (open-to-close or close-to-open) confirm that the 'fault' light is on when the damper is between open and closed (25 to 70 degrees of stroke). **Do not insert objects between damper blades to restrict damper travel.** Objects may destroy blade edge seals, deform blades and/or damage linkage, which will void the product warranty and invalidate UL ratings.

Troubleshooting Guide

Problem	Possible Cause	Solution
Damper does not operate, or will not open and/or close fully	Installation screws interfering with damper blade or linkage travel	Inspect and remove interfering screws or debris
	Damper heat responsive device is tripped.	Push reset button (located on HS-10 or DRS-30 junction box)
	Frame is 'racked' causing blades to bind	Adjust frame to be square and plumb
	Contaminants on damper	Clean with compressed air, mild detergent or mild non-petroleum based solvent
	Loose actuator set screws or linkage	Disconnect power to close damper, loosen actuator set screws, adjust linkage (if applicable), tighten actuator set screws, reapply power
	No power supplied to the actuator	Connect power
	Defective actuator	Disconnect power and loosen actuator set screws, cycle actuator. If good, reconnect. If bad, contact the factory
Corresponding control panel indicating light does not illuminate when damper is open and/or closed	System wiring/program is faulty	Verify wiring is correct. If it is, then disconnect system wires from damper indicator switch and test open/closed switch continuity directly. If good, reconnect system wires and correct system fault. If bad, contact the factory.
	Defective switch	Contact factory if above test shows no continuity with damper either full open or full closed

The following installation details apply to models **FSD-151** and **FSD-152 (2000 fpm)**

Notes

- The details shown below reflect maximum actuator/damper size limitations based on testing to UL-555S and default, 2-position, spring-return electric actuators rated for maximum 2000 fpm at 4" static pressure.
- All actuators must be factory installed and multiple actuators on a single assembly are factory wired to a common connection.
- Dampers larger than 32" w x 48" h are manufactured in multiple section assemblies consisting of equal size sections not exceeding 32" w x 48" h.
- Actuators installed out of the air stream may extend above or below the height of the damper. Refer to table below for details.

		Damper Width (w) in inches																																
		8	12	16	20	24	28	32	36	40	44	48	52	56	60	64	68	72	76	80	84	88	92	96	100	104	108	112	116	120	124	128		
Damper height (h) in inches	8	$w \leq 32"$ and $h \leq 48"$ Detail #11 - 1 $32" < w \leq 64"$ and $33" < h \leq 48"$ Detail #21 - 2 $64" < w \leq 96"$ and $33" < h \leq 48"$ Detail #31 - 3 $96" < w \leq 128"$ and $33" < h \leq 48"$ Detail #41 - 4																1 Section High																
	12																	2 Section High																
	16	$w \leq 32"$ and $48" < h$ Detail #12 - 2 $32" < w \leq 64"$ and $48" < h \leq 66"$ Detail #22 - 2 $64" < w \leq 96"$ and $48" < h \leq 66"$ Detail #32 - 4 $96" < w \leq 128"$ and $48" < h \leq 66"$ Detail #42 - 4 $32" < w \leq 64"$ and $66" < h \leq 96"$ Detail #22 - 4 $64" < w \leq 96"$ and $66" < h \leq 96"$ Detail #32 - 6 $96" < w \leq 128"$ and $66" < h \leq 96"$ Detail #42 - 8																2 Section High																
	20																	2 Section High																
	24																																	
	28																																	
	32																																	
	36																																	
	40																																	
	44																																	
	48																																	
	52																																	
	56																																	
	60																																	
	64																																	
	68																																	
	72																																	
	76																																	
	80																																	
	84																																	
	88																																	
	92																																	
	96																																	
	100																																	
	104																																	
	108																																	
	112																																	
	116																																	
	120																																	
	124																																	
	128																																	
		1 Section Wide				2 Section Wide				3 Section Wide				4 Section Wide																				

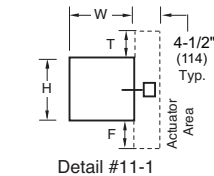

	Damper Height	Damper Width	
		w ≤ 36"	w > 36"
F	6"-7"	5"	7"
	8"-9"	4"	7"
	10"-11"	1"	4"
	12"-13"	0"	3"
	14"	0"	2"
	15"-16"	0"	1"
	17"	0"	3"
> 17"	0"	0"	
T	6", 10"	3"	3"
	7", 11"-12"	2"	2"
	8", 13"-14", 21"	1"	1"
	9", 15"-17", 20"	0"	0"
	18"-19"	0"	1"
	> 21"	0"	0"

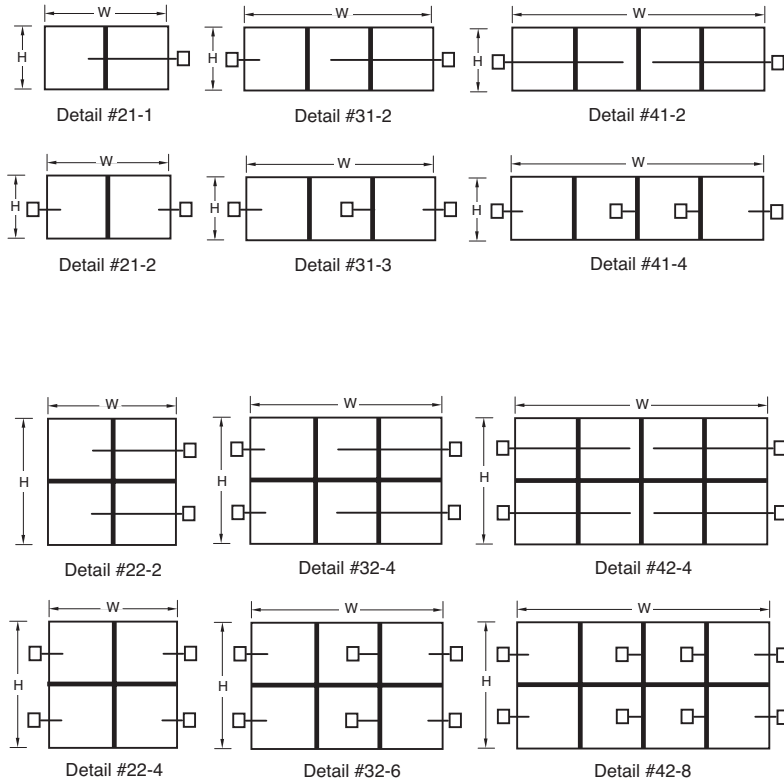
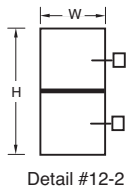

The following installation details apply to models **FSD-151** and **FSD-152 (3000 fpm)**

Notes

- The details shown below reflect maximum actuator/damper size limitations based on testing to UL-555S and default, 2-position, spring-return electric actuators rated for maximum 3000 fpm at 4" static pressure.
- All actuators must be factory installed and multiple actuators on a single assembly are factory wired to a common connection.
- Dampers larger than 32" w x 48" h are manufactured in multiple section assemblies consisting of equal size sections not exceeding 32" w x 48" h.
- Actuators installed out of the air stream may extend above or below the height of the damper. Refer to table below for details.

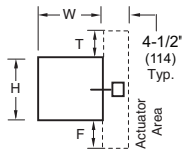
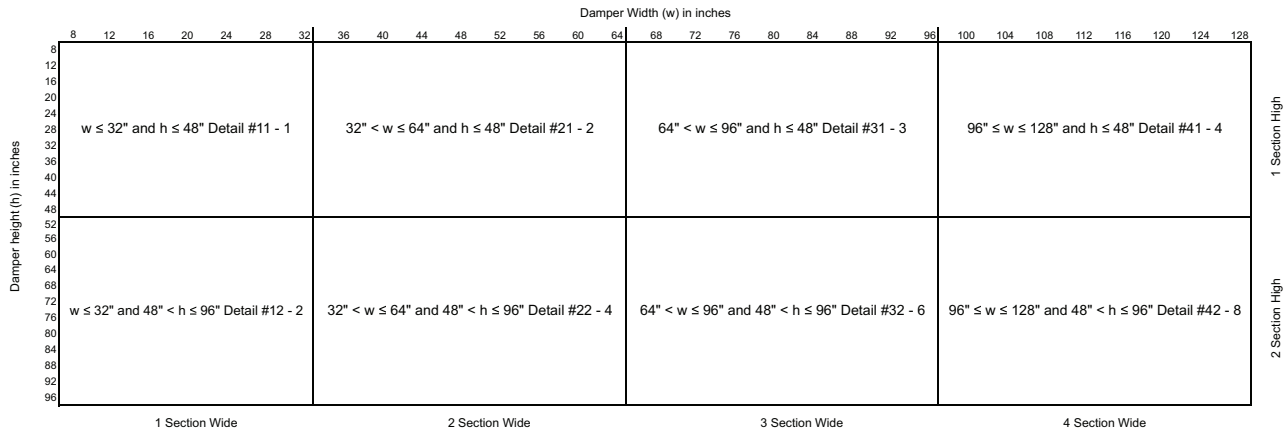

Detail #11-1

	Damper Height	Damper Width	
		w ≤ 32"	w > 32"
F	6"-7"	5"	7"
	8"-9"	4"	7"
	10"-11"	1"	4"
	12"-13"	0"	3"
	14"	0"	2"
	15"-16"	0"	1"
	17"	0"	3"
	> 17"	0"	0"
T	6", 10"	3"	3"
	7", 11"-12"	2"	2"
	8", 13"-14", 21"	1"	1"
	9", 15"-17", 20"	0"	0"
	18"-19"	0"	1"
	> 21"	0"	0"

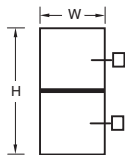

Detail #12-2

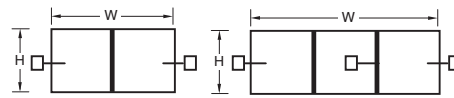

Detail #21-2

Detail #31-3

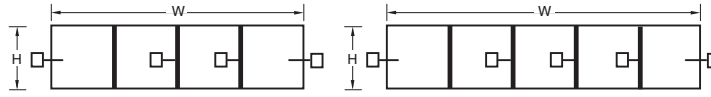

Detail #41-4

Detail #51-5

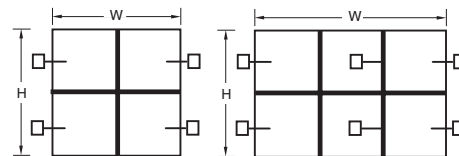

Detail #22-4

Detail #32-6

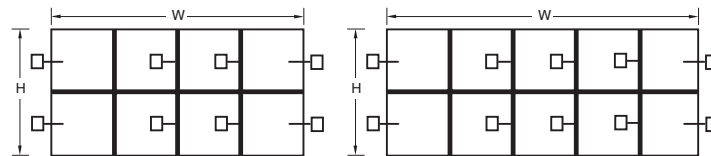

Detail #42-8

Detail #52-10

Maintenance

Dampers do not typically require maintenance provided they are kept clean and dry. All moving parts are self-lubricating and additional lubrication is not required. If additional lubrication of multi-blade damper axle bearings, jackshaft bearings or jamb seals is desired, use a silicone or dry graphite lubricant. **Do not use petroleum-based lubricants or other lubricants that attract contaminants and collect dust.**

Operational Testing

• *Non-Spring Assisted Damper*

Operate the damper by removing the fusible link (or by 'melting' the fusible link with a heat source) and allowing the blades to drop or close naturally. **CAUTION - Avoid injury - keep clear of blade travel path.** Lift the blade package to the top of the damper to reopen and replace the fusible link. Take care not to rack, deform or damage the blades while reopening.

• *Dynamic Rated OR Spring Assisted Dampers*

Due to spring assisted closure force, removing the fusible link is NOT recommended as a means of closure testing. Instead, when testing is required, 'melt' the fusible link with an appropriate heat source and allow the blades to close automatically. **CAUTION - Avoid injury - Keep clear of blade travel path.** Lift the blade package to the top of the damper to reopen and replace the fusible link. Take care not to rack, deform or damage the blades when reopening.

Reopening Spring Assisted OR Dynamic Rated Fire Dampers may be very difficult and in some cases impossible. If the damper is deemed impossible or impractical to test or reopen, then a thorough examination of the blade travel path is required to insure that nothing will prevent the damper from closing. Common obstructions include: retaining angle installation screws, racked damper frames, construction debris and contaminants.

CAUTION - Testing Spring Assisted OR Dynamic Rated Fire Dampers under airflow conditions is not recommended and may severely damage or destroy duct work.

Troubleshooting Guide

Problem	Possible Cause	Solution
Damper does not operate, or will not open and/or close fully	Installation screws interfering with damper blade or linkage travel	Inspect and remove interfering screws or debris
	Frame is 'racked' causing blades to bind	Adjust frame to be square and plumb
	Contaminants on damper	Clean with compressed air, mild detergent or mild non-petroleum based solvent
Fusible link is separated	Excessive heat	Replace link. Note: If the damper is installed near a heat source (heat exchanger, burner, furnace, etc.) higher temperature links may be required to prevent unwanted closure.

The following installation details apply to models **VFD-10, VFD-10D, VFD-10TL** and **VFD-10D-TL**

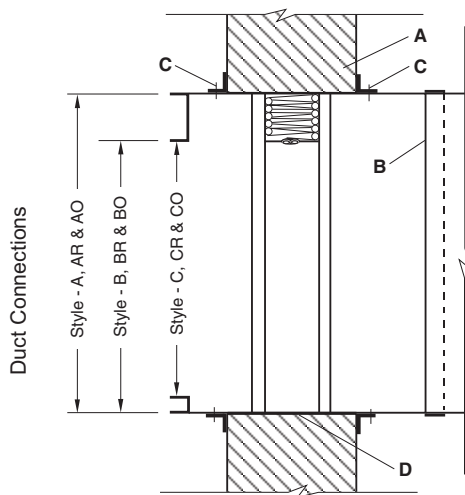

**Damper Installation For Typical
Fire Rated Partition**

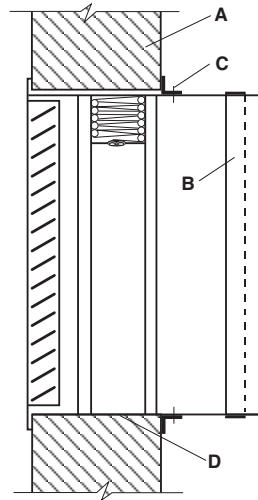

**Damper Installation For Typical
Flange Termination with Grille / Register**

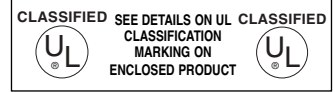

- A. Concrete or masonry fire partition shown. See Wood Stud and/or Steel Stud Framing for Fire Dampers In Drywall and/or Cavity Shaftwall Partitions Supplemental Installation Instructions for further vertical installation details. The opening shall be a minimum of 1/4" (6) with a maximum of 3/4" (19) larger than the overall damper and sleeve assembly size. When openings are larger than 3/4" (19), but less than 6" (152) the mounting angles must be a minimum of 16 gauge (1.5) and must be tall enough to overlap the opening by a minimum of 1" (25). Damper must be installed with leading edge of closed blade within the partition.
- B. For rigid type duct connections, the sleeve shall be a minimum of 16 gauge (1.5) for dampers up to 36" wide by 24" high (914 x 610) and 14 gauge (1.9) for larger units. When lighter gauge sleeves are used, one or more of commonly used breakaway style connections are required. Refer to Sleeve Termination Supplemental Installation Instructions for further details. In no case will the sleeve gauge be less than the duct gauge to which it is connected. Damper sleeve shall not extend more than 6" (152) beyond the rated partition unless an access door or Smoke Detector is installed in the sleeve which then permits the extension to be a maximum of 16" (406).
- C. Mounting angles shall be a minimum of 3/4" x 1-1/2" tall x 20 gauge (19 x 38 x 1.0). For opening sizes ≤ 80" wide (2032), 96" high (2438), and not exceeding 26.67 square feet in area retaining angles are only required on one side of the partition and must be attached to the sleeve and the partition. For larger openings (or optional on smaller openings), 1-1/2" x 1-1/2" x 16 gauge (38 x 38 x 1.5). retaining angles are required on both sides of the partition and must be attached to the sleeve. Attachment to the sleeve shall be with No. 10 (M5) screws or bolts, 3/16" (4.8) diameter steel rivets, Quick-Lock joints or welds, at 12" (305) o.c. maximum. Attachment to partition/opening shall be with min. No. 10 fasteners with a minimum length as follows: For metal stud and the angles under the drywall, the fasteners must be a min. 1/2" long. For metal stud and the angles over the drywall the fastener must be a min. 1/2" longer than the thickness of the drywall. i.e. if the partition has one layer of 5/8" drywall on the attachment side, the screws must be 1/2" + 5/8" = 1-3/8" long. For wood stud openings, the min. length is 1-1/2" longer than the thickness of drywall on the attachment side. For concrete or masonry openings, the anchors must be for min. No. 10 fasteners- screws or bolts. In lieu of masonry anchors and bolts/screws, self-tapping masonry screws can be used. The fasteners in the partition should be located such that they are 1/2" below the top of the 1-1/2" flange of the retaining angles. Fasteners in the partition should be spaced 12" o.c. max. A minimum of two connections per side, top and bottom. A minimum 3/4" x 20 gauge (19 x 1) flange termination may be used in lieu of mounting angles. Refer to Sleeve Termination Supplemental Installation Instructions and Framing for Fire Dampers for further details. Ensure that attachment device does not interfere with the operation of the damper and the free movement of the damper blades. Note: If optional sealing between the retaining angle (or flange) leg and the surface of the partition, wall, or floor, and/or between the retaining angle leg and the surface of the damper sleeve is required, the following sealants may be used: Dow Corning 732 or DOWSIL 732 or GE RTV 108 or SCS 1201 RTV. These sealants should be applied such that they do not intrude into the annular space between the outside surface of the damper sleeve and the opening of the partition, wall, or floor, into which the damper/sleeve is being installed.

Note:

Annular space between damper sleeve and wall opening shall not be filled with firestop materials such as fill, void or cavity materials.

*Maximum single section is 36" x 36" (914 x 914) for multiple sections larger than 36" x 96" (914 x 2438) or 72" x 48" (1829 x 1219)

DUCT SIZES	Model VFD-10		Model VFD-10D		Model VFD-10-TL	Model VFD-10D-TL
	GALVANIZED STEEL	STAINLESS STEEL	GALVANIZED STEEL	STAINLESS STEEL	GALVANIZED STEEL	GALVANIZED STEEL
Maximum Single Section	48" x 48" (1219 x 1219)	40" x 40" (1016 x 1016)	*36" x 48" (914 x 1219)	36" x 36" (914 x 914)	36" x 48" (914 x 1219)	36" x 48" (914 x 1219)
Maximum Multiple Section	120" x 80" or 80" x 120" (3048 x 2032)(2032 x 3048)	80" x 40" or 40" x 80" (2032 x 1016)(1016 x 2032) 108" x 24" (2743 x 610)	*120" x 72" or 72" x 120" (3048 x 2032)(2032 x 3048)	NA	36" x 72" or 72" x 36" (915 x 1829)(1829 x 915)	36" x 72" or 72" x 36" (915 x 1829)(1829 x 915)
Minimum	4" x 4" (102 x 102)	4" x 4" (102 x 102)	6" x 6" (152 x 152)	6" x 6" (152 x 152)	4" x 4" (102 x 102)	6" x 6" (152 x 152)

Product Listing Underwriter's Laboratories file #R11767 and CSFM File # 3225-0368:101

Information is subject to change without notice or obligation.

NOTE: Dimensions in parentheses () are millimeters.

The following installation details apply to models **VFD-10D** and **VFD-10**

Duct Connections

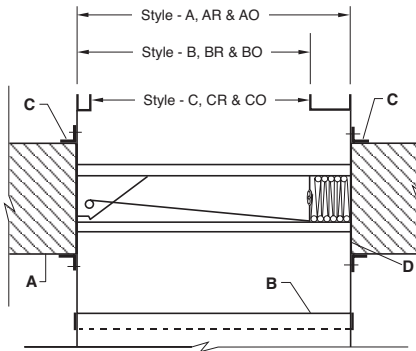

**Damper Installation
(2-sided Mounting Angle)**

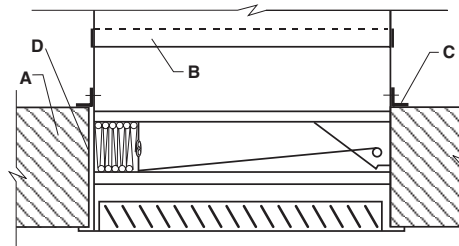

**Damper Installation For Typical
Flange Termination with Grille / Register**

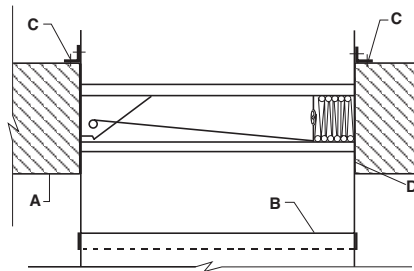

Single Side Mounting Angle Damper Installation

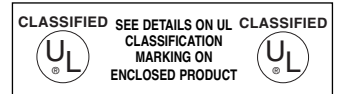

- A.** Concrete or masonry fire partition shown. The opening shall be a minimum or equal to ¼" (6) with a maximum of ¾" (19) larger than the overall damper and sleeve assembly size. When openings are larger than ¾" (19), but less than or equal to 6" (152) the mounting angles must be a minimum of 16 gauge (1.5) and must be wide enough to overlap the opening by a minimum of 1" (25). Damper must be installed with leading edge of closed blade within the partition.
- B.** For rigid type duct connections, the sleeve shall be a minimum of 16 gauge (1.5) for dampers up to 36" wide by 24" high (914 x 610) and a minimum of 14 gauge (1.9) for larger units. When lighter gauge sleeves are used, one or more of commonly used break away style connections are required. Refer to Sleeve Termination Supplemental Installation Instructions for further details. In no case will the sleeve gauge be less than the duct gauge to which it is connected. Damper sleeve shall not extend more than 6" (152) beyond the rated partition unless an access door or Smoke Detector is installed in the sleeve which then permits the extension to be a maximum of 16" (406).
- C.** Mounting angles shall be a minimum 1-½" x 1-½" x 16 gauge (38 x 38 x 1.5). Mounting angles are only required on the top side of the opening and must be attached to the sleeve at 6" (152) o.c. maximum, to the partition at 24" (610) o.c. maximum, with a minimum of two fasteners per side to both the sleeve and partition on all four sides. Alternately, mounting angles may be installed on both sides of the partition and must be attached only to the sleeve at 12" (305) o.c. maximum, with a minimum of two connections per side on all four sides. Attachment to the sleeve shall be a minimum of No. 10 (M5) steel fasteners: anchors, bolts, or self-tapping masonry screws. A minimum ¾" x 20 gauge (19 x 1) flange termination may be used in lieu of mounting angles. Ensure that the attachment device does not interfere with the operation of the damper and the free movement of the damper blades.

Note: If optional sealing between the mounting angle (or flange) leg and the surface of the partition, or floor, and/or between the mounting angle leg and the surface of the damper sleeve is required, the following sealants may be used: Dow Corning 732 or DOWSIL 732 or GE RTV 108 or SCS 1201 RTV. These sealants should be applied such that they do not intrude into the annular space between the outside surface of the damper sleeve and the opening of the partition, or floor, into which the damper sleeve is being installed. Annular space between damper sleeve and opening shall not be filled with firestop materials such as fill, void, or cavity materials.

- D.** When joining multiple sections or fastening the damper to the sleeve, the damper shall be fastened with ¾" (4.8) diameter steel rivets, Quick-Lock Joints, welds, No. 10 (M5) bolts or sheet metal screws at 8" (203) o.c. maximum. A minimum of two connections per side, top and bottom.

DUCT SIZES	Model VFD-10	VFD-10D	Model VFD-10
	GALVANIZED STEEL		STAINLESS STEEL
Maximum Single Section	40" x 40" (1016 x 1016)	36" x 36" (914 x 914)	40" x 40" (1016 x 1016)
Maximum Multiple Section	80" x 80" (2032 x 2032)	36" x 36" or 72" x 18" (914 x 914) (1829 x 457)	80" x 40" or 40" x 80" (2032 x 1016) (1016 x 2032)

Underwriter's Laboratories file #R11767. The product is also listed by CSFM File # 3225-0368:101.

Individually sleeved dampers can be installed in partitions wider than the maximum U.L. multiple section size using the Support Mullion for Oversized Floor Openings. See Support Mullion for Oversized Floor Openings Installation Instructions for further details.

The following installation details apply to models **VFD-10**, **VFD-10D**, **VFD-10TL** and **VFD-10D-TL**

- D. When joining multiple sections or fastening the dampers to the sleeve, the damper shall be fastened with 3/16" (4.8) diameter steel rivets, Quick-Lock joints, welds or No. 10 (M5) bolts or sheet metal screws at 8" (203) o.c. maximum if multiple sections assemblies are smaller than 36" x 96" (914 x 2438) and 72" x 48" (1829 x 1219) or 6" (152) o.c. maximum for multiple sections larger than 36" x 96" (914 x 2438) and 72" x 48" (1829 x 1219). There must be a minimum of two connections per side, top and bottom.

On multiple sections larger than 36" x 96" (914 x 2438) and 72" x 48" (1829 x 1219) the maximum single section size shall be 36" x 36" (914 x 914).

For assemblies multiple sections wide and multiple sections high a minimum 14 gauge x 5" (127) wide supplemental steel mullion plate is required. The mullion plate length should be either full length or full height of the multiple sections assembly. The mullion plate must be installed between adjacent damper frames running parallel to the sleeve/duct width/height. Mullions are not required for dampers assemblies that are single sections wide and multiple high or single sections high and multiple wide.

The support mullion must be attached to the damper frames using welds or No. 10 (M5) bolts, sheet metal screws or minimum 3/16" (4.8) diameter steel rivets at 6" (152) o.c. maximum and 1" maximum from the frame corner.

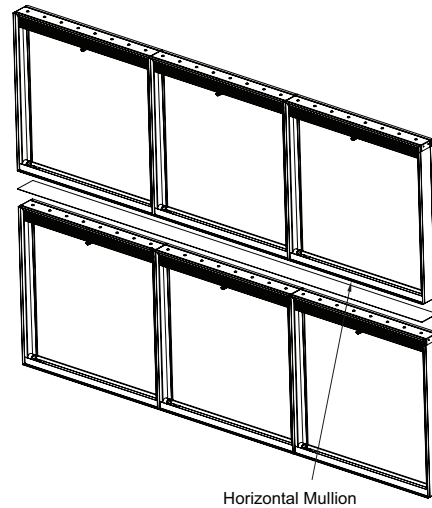
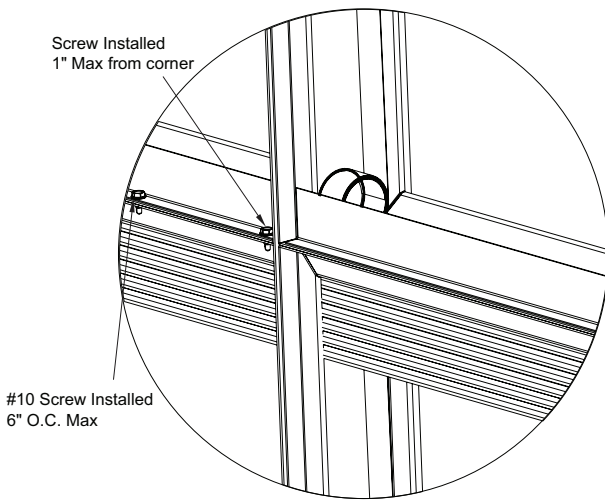



Submittal # 85092

APPROVAL REQUIRED

Project 22104386-MECH-1- Brampton Victoria Park Arena
Leader Nevin Wong
Job Site Brampton Victoria Park Arena
Submission Date 2025-01-29
Sold To CONSULT MECH
Submitted By Lindsay Grahame

Contacts

Role	Customer	Contact	Our Rep
Mechanical Contractor	Con-Sult Mechanical Inc.*	Inzaman Khan	Nevin Wong
General Contractor	Rafat General Contracing Inc		
Mechanical Contractor	Con-Sult Mechanical Inc.*	Mohammed Ali Khan Lodhi	Nevin Wong
Mechanical Contractor	Con-Sult Mechanical Inc.*	Paul Leddy	Nevin Wong
Designer	WSP MMM Group		Alex Forsea

Deliverables

Track #	290259		
Tag	LOUVERS		
Description	Louvers		
Manufacturer	POTTORFF		
Production Lead Time	6 - 8 weeks		
Revision #	0		

Notes:

Contractor to confirm size, quantities, and frame style prior to ordering.

Lead times are estimated and subject to change on short notice

Attention:

- 1) HTS will provide equipment in accordance with the attached shop drawings.
- 2) Upon approved submittal and customer release, HTS will release equipment to fabrication per the published lead times. Any storage fees associated with project schedule changes will be the responsibility of the purchaser.
- 3) HTS can provide freight and logistics to the purchaser as an added benefit of doing business with HTS. When freight is received by the purchaser, any noticeable damage must be recorded. Otherwise, HTS is not responsible for subsequent damage claims.

Approval Stamps

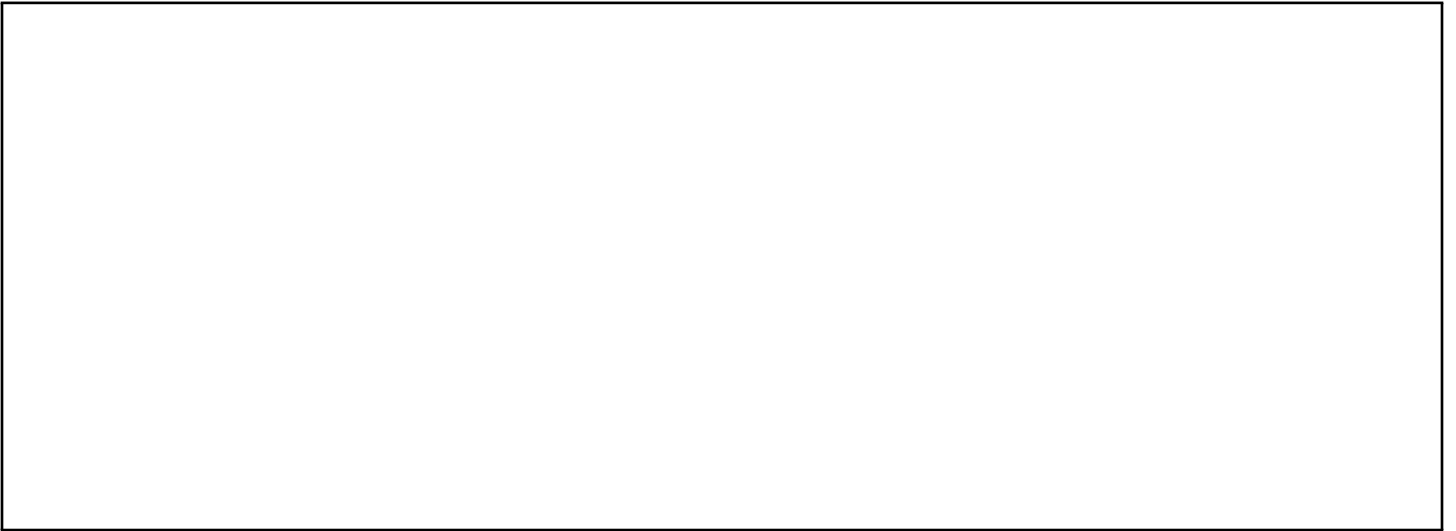
A large, empty rectangular box with a thin black border, intended for placing approval stamps. The box is currently blank.

Specifications

2.27 LOUVRES

- .1 Price Industries Inc. DE439 or DE635, 100 mm (4") or 150 mm (6") deep (to suit wall thickness) factory assembled stationary, drainable, storm-proof louvres sized as indicated on drawings, each AMCA water penetration and air performance certified, constructed of welded, extruded, alloy 6063-T5 aluminum with drainable blades, mounting and securing hardware to suit the application, and 12 mm (½") mesh aluminum birdscreen in an aluminum frame.

Louvers

POTTORFF®

EFD-435

Extruded Aluminum Louver
4" deep • 35° Drainable Blade

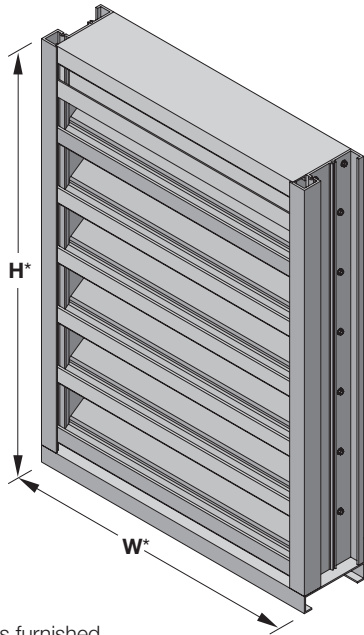

EFD-435

(standard)

*Louver dimensions furnished approximately 1/2" (13) undersize.

The EFD-435 drainable blade louver is designed to prevent water penetration in non-wind-driven rain applications by collecting water in frame and blade gutters and channeling it into downspouts and away from airflow paths. The EFD-435 is available in a wide array of anodized and painted finishes including custom color matching.

Standard Construction

- Material:** Mill finish 6063-T5 extruded aluminum
- Frame:** 4" deep × 0.081" thick (102 × 2) channel
- Blades:** 35° × 0.081" (2) thick drainable style
- Screen:** 1/2" × 0.063" (12.7 × 1.6) expanded and flattened aluminum
- Mullion:** Visible
- Minimum Size:** 4.5" × 6.5" (114 × 165)
- Maximum Size:**
 - Single section: 60" × 120" (1524 × 3048)
 - 120" × 60" (3048 × 1524)
 - Multiple section: Unlimited

Ratings

Free Area: [48" × 48" (1219 × 1219) unit]: 9.3 ft² (0.86 m²)
58.1%

Performance @ Beginning Point of Water Penetration

Free Area Velocity: 966 fpm (4.91 m/s)

Air Volume Delivered: 8,984 cfm (4.24 m³/s)

Pressure Loss: 0.12 in.wg. (30 Pa)

Velocity @ 0.15 in.wg. Pressure Loss: 1,077 fpm (5.47 m/s)

Design Load: 30 psf

Options

■ Factory finish:

- Baked Enamel

■ Frame Options:

- 1-1/2" (38) flange frame

Contractor to confirm mounting channel frame or flange frame



Certified Ratings:

Pottorff certifies that the model EFD-435 shown herein is licensed to bear the AMCA seal. The ratings shown are based on test and procedures performed in accordance with AMCA Publication 511 and comply with the requirements of the AMCA Certified Ratings Program. The AMCA Certified Ratings seal applies to air performance and water penetration ratings.

NOTE: Dimensions in parentheses () are millimeters. Information is subject to change without notice or obligation.

5 year warranty

PERFORMANCE

EFD-435

Extruded Aluminum Louver
4" deep • 35° Drainable Blade

Free Area (ft²)

Width (Inches)

Height (Inches)	Width (Inches)																		
	12	18	24	30	36	42	48	54	60	66	72	78	84	90	96	102	108	114	120
12	0.3	0.5	0.7	0.9	1.1	1.4	1.6	1.8	2.0	2.2	2.4	2.6	2.8	3.0	3.2	3.4	3.6	3.8	4.0
18	0.6	1.0	1.4	1.7	2.1	2.5	2.8	3.2	3.6	3.9	4.3	4.7	5.0	5.4	5.8	6.1	6.5	6.9	7.3
24	0.9	1.4	2.0	2.5	3.0	3.6	4.1	4.7	5.2	5.7	6.3	6.8	7.4	7.9	8.4	9.0	9.5	10.0	10.6
30	1.2	1.9	2.6	3.3	4.0	4.7	5.4	6.1	6.8	7.5	8.2	8.9	9.6	10.3	11.0	11.7	12.5	13.2	13.9
36	1.5	2.3	3.2	4.1	4.9	5.8	6.7	7.6	8.4	9.3	10.2	11.1	11.9	12.8	13.7	14.6	15.4	16.3	17.2
42	1.7	2.8	3.8	4.9	5.9	6.9	8.0	9.0	10.1	11.1	12.1	13.2	14.2	15.3	16.3	17.3	18.4	19.4	20.5
48	2.0	3.2	4.4	5.6	6.8	8.1	9.3	10.5	11.7	12.9	14.1	15.3	16.5	17.7	18.9	20.1	21.3	22.6	23.8
54	2.3	3.7	5.0	6.4	7.8	9.2	10.5	11.9	13.3	14.7	16.0	17.4	18.8	20.2	21.6	22.9	24.3	25.7	27.1
60	2.6	4.1	5.7	7.2	8.7	10.3	11.8	13.4	14.9	16.5	18.0	19.5	21.1	22.6	24.2	25.7	27.3	28.8	30.4
66	2.9	4.6	6.3	8.0	9.7	11.4	13.1	14.8	16.5	18.2	20.0	21.7	23.4	25.1	26.8	28.5	30.2	31.9	33.6
72	3.1	5.0	6.9	8.8	10.6	12.5	14.4	16.3	18.2	20.0	21.9	23.8	25.7	27.6	29.4	31.3	33.2	35.1	36.9
78	3.4	5.5	7.5	9.5	11.6	13.6	15.7	17.7	19.8	21.8	23.9	25.9	28.0	30.0	32.1	34.1	36.1	38.2	40.2
84	3.7	5.9	8.1	10.3	12.5	14.8	17.0	19.2	21.4	23.6	25.8	28.0	30.3	32.5	34.7	36.9	39.1	41.3	43.5
90	4.0	6.3	8.7	11.1	13.5	15.9	18.3	20.6	23.0	25.4	27.8	30.2	32.5	34.9	37.3	39.7	42.1	44.4	46.8
96	4.2	6.8	9.3	11.9	14.4	17.0	19.5	22.1	24.6	27.2	29.7	32.3	34.8	37.4	39.9	42.5	45.0	47.6	50.1
102	4.5	7.2	10.0	12.7	15.4	18.1	20.8	23.5	26.3	29.0	31.7	34.4	37.1	39.8	42.6	45.3	48.0	50.7	53.4
108	4.8	7.7	10.6	13.5	16.3	19.2	22.1	25.0	27.9	30.8	33.6	36.5	39.4	42.3	45.2	48.1	50.9	53.8	56.7
114	5.1	8.1	11.2	14.2	17.3	20.3	23.4	26.4	29.5	32.5	35.6	38.7	41.7	44.8	47.8	50.9	53.9	57.0	60.0
120	5.4	8.6	11.8	15.0	18.2	21.5	24.7	27.9	31.1	34.3	37.6	40.8	44.0	47.2	50.4	53.7	56.9	60.1	63.3

Water Penetration

AMCA defines the beginning point of water penetration as the free area velocity at the intersection of a simple linear regression of test data and the line of 0.01 ounces of water per square foot of free area and is measured through a 48" x 48" louver during a 15 minute period. The AMCA water penetration test provides a method for comparing louver models and designs as to their efficiency in resisting the penetration of rainfall under specific lab conditions. We recommend that intake louvers are selected with a reasonable margin of safety below the beginning point of water penetration in order to avoid unwanted penetration during severe storm conditions.

Beginning Point of Water Penetration = 966 fpm

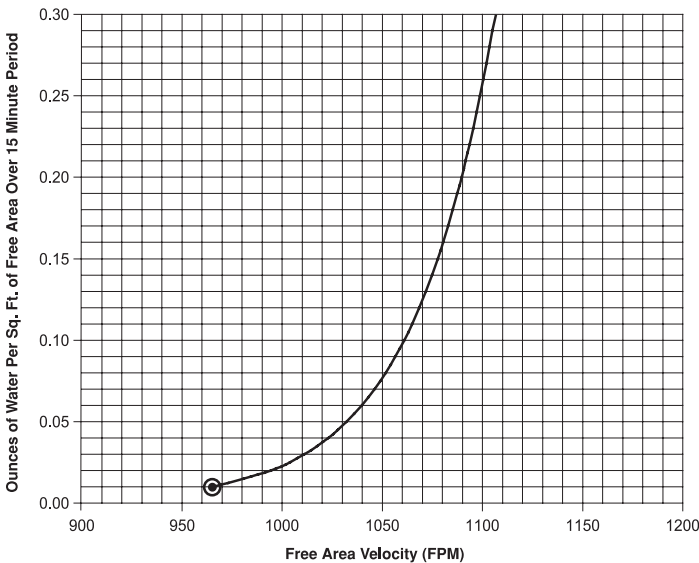

Certified Ratings:

Pottorff certifies that the model EFD-435 shown herein is licensed to bear the AMCA seal. The ratings shown are based on test and procedures performed in accordance with AMCA Publication 511 and comply with the requirements of the AMCA Certified Ratings Program. The AMCA Certified Ratings seal applies to air performance and water penetration ratings.

Pressure Loss

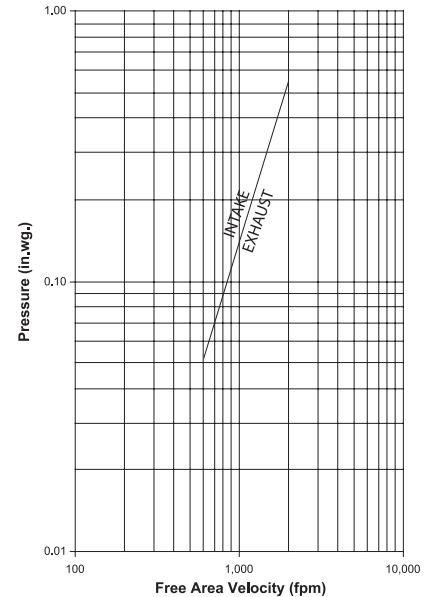

Louver Test Size = 48" x 48" (1219 x 1219)







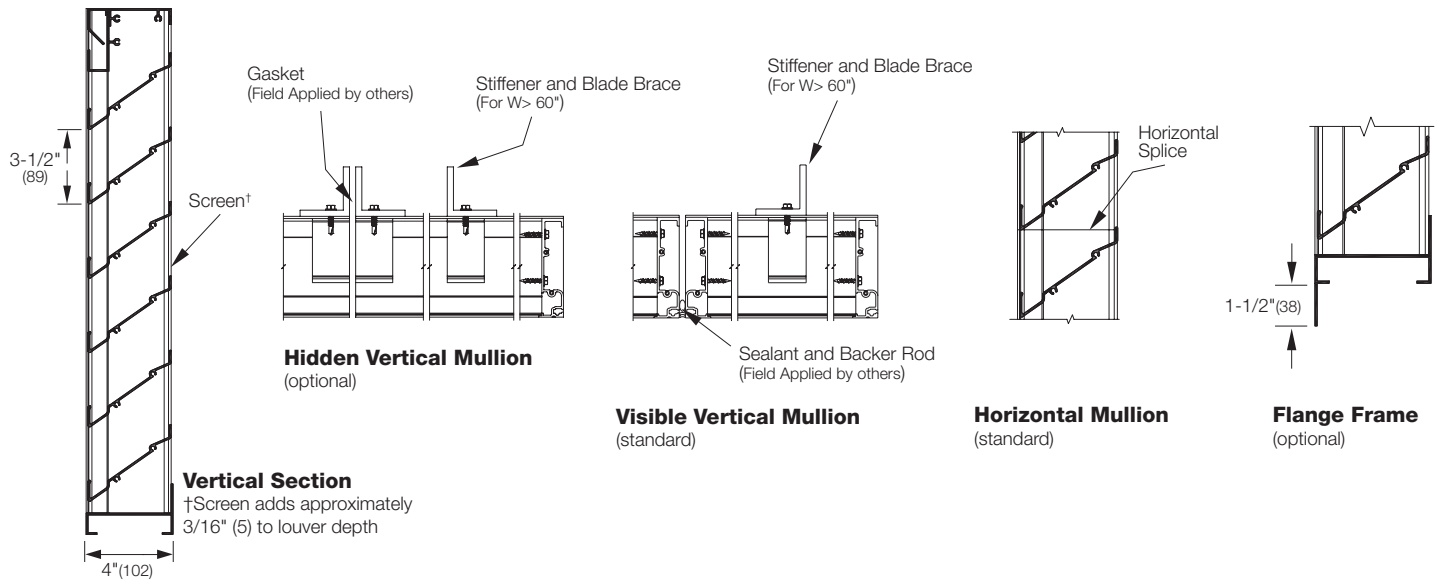



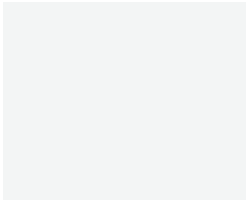





EFD-435

Extruded Aluminum Louver
4" deep • 35° Drainable Blade

Attributes

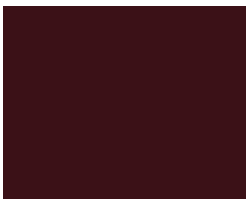
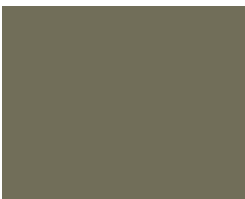
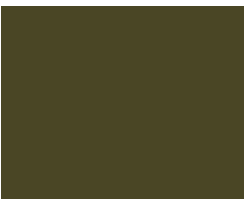

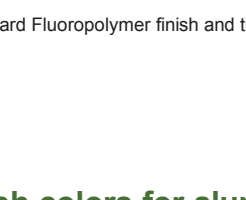
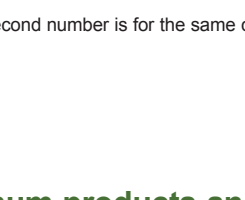
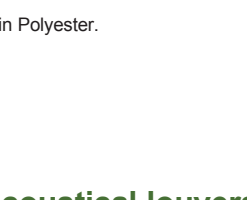
Standard Finish colors for aluminum products and acoustical louvers

			
Apollo White M-18136 M-19136	Bone White M-18137 M-19137	Colonial White M-18138 M-19138	Ivory M-18162 M-19162
			
Sandstone M-18139 M-19139	Nantucket Dune M-18140 M-19140	Beige M-18141 M-19141	Seawolf M-18142 M-19142
			
Fashion Gray M-18143 M-19143	Colonial Gray M-18144 M-19144	Charcoal Gray M-18145 M-19145	Light Blue M-18146 M-19146
			
Interstate Blue M-18147 M-19147	Aged Copper M-18148 M-19148	Hartford Green M-18149 M-19149	Brick Red M-18150 M-19150
			
Burgundy M-18151 M-19151	Sage Brown M-18152 M-19152	Statuary Bronze M-18153 M-19153	Black M-18154 M-19154

The first M number is for the standard Fluoropolymer finish and the second number is for the same color in Polyester.

Premium Pearl finish colors for aluminum products and acoustical louvers

			
El Cajon Silver M-18155 M-19155	Champagne M-18156 M-19156	Light Bronze M-18157 M-19157	Medium Bronze M-18158 M-19158
			
Dark Bronze M-18159 M-19159	Dark Bronze M-18159 M-19159	Dark Bronze M-18159 M-19159	Dark Bronze M-18159 M-19159

Premium Pearl colors use mica pigments to simulate the appearance of anodized finishes. The first M number is for the standard Fluoropolymer finish and the second number is for the same color in Polyester.

The color samples shown are not the actual paint. The samples are as close as possible to actual colors offered. Actual coating samples are available upon request. Please call us at 817-509-2300 or e-mail us at info@pottorff.com to request a sample of our color chart.

Our superior performance paint systems are available in a wide range of colors and we can also custom color match to any of your specifications. Our expertise in applying architectural coatings assures you of a high quality finish. With our color options, you get the color you need when you need it!

PRODUCT FACTS

Finish Type	Description/Application	Color Selection	Warranty
Fluoropolymer; Decaflon or Newlar meet AAMA 2605. Dry film thickness 2 mil. equivalent to Kynar 500®/Hylar 5000®, Duranar®, Fluoropon®	Our premier finish for extruded aluminum. Tough, long lasting, environmentally friendly powder coating has superior color retention and abrasive properties. Resists chalking, fading, chemical abrasion and weathering.	Standard Colors: 20 standard colors plus Premium Pearl finishes. Custom colors are available. Consult factory.	10 Years (consult factory for availability of extended warranty up to 20 years).
Polyester Powder Coat meets AAMA 2604 dry film thickness 2 mil. equivalent to Baked Enamel.	Environmentally friendly powder coating has good color retention and abrasive properties. Resists chalking, fading, chemical abrasion and weathering.	20 standard colors for aluminum products and acoustical louvers, 18 colors for steel. Custom colors are available. Consult factory.	5 Years
Integral Color Anodize AA-M10C22A42 (>0.7 mil)	Electrochemically deposited inorganic color pigment which is sealed to convert an aluminum oxidation into a corrosion resistant finish. Some shade variation will occur.	Champagne; Light, Medium or Dark Bronze; Black	5 Years
Clear Anodize 215 R-1 AA-M10C22A41 (>0.7 mil)	Electrochemically oxidized aluminum surface for uniform clear finish. More resistant to natural oxidizing. Improved luster and less glossy than mill finish.	Clear	5 Years
Gray Acroprime Prime Coating	A chrome-free thermoset primer which meets AAMA 2605 specifications and accepts most common field-applied paints. Dry cross hatch testing is recommended for any finish applied to ensure proper inner coat adhesion between top coat and primer. See Pottorff's Primer Product Data Sheet for more details.	N/A	N/A
Mill	Aluminum or Galvanized Steel. Normal weathering will occur.	N/A	N/A



Finishes enhance louver appearance by matching or contrasting with adjacent surfaces and extending weather resistance. Color matching is available upon request.

Installation
Operation
Maintenance

General

The following guidelines provide basic assembly and installation instructions for standard Pottorff extruded aluminum stationary blade louvers. Most Pottorff standard louvers are designed to resist a 30 psf wind load.

1. Consult with the Engineer of record for the size, type, and surrounding condition.
2. Refer to job-specific submittal drawings for additional details when provided.
3. Carefully lift louver sections by their frames or support members using multiple lifting points if necessary to avoid distortion, racking or damage. **Do not apply excessive force to a single point and NEVER LIFT UNITS BY LOUVER BLADES.** Take necessary precautions to prevent marring the louver finish.
4. Caulk and anchors are by others. Proper isolation (by others) is recommended between aluminum louver components and steel building conditions to prevent corrosion.

Preparation





Louvers and Hardware

1. Locate all crates, boxes, cartons, etc.
2. Remove louvers from packaging, inspect for damage, confirm quantities and sizes with packing list, and organize parts in order of installation. If installation hardware was ordered it will typically be in a separate box.
3. Notify your Pottorff representative immediately of any shortages or shipping damage.

Openings

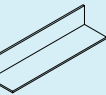
1. Inspect openings for damage, repair as needed, and remove obstructions and debris as required.
2. Verify that openings are square, plumb, and that the louvers will fit properly prior to installation.

Table 1: Installation Hardware

Part	Description		
A-1	Clip Angle (1-1/2" x 2" x 1/8" x 4" long; 6061-T6 Aluminum)		Optional by Pottorff
A-2	Extended Clip Angle (1-1/2" x 2" x 1/8" x 8" long; 6061-T6 Aluminum)		Optional by Pottorff (multi-section high assemblies only)
F-1	#12-14 x 3/4" Hex Head Self-Drilling Screw		Included with clip angles
F-2	1/4"-20 x 1-1/4" Hex- Head Bolt, Locknut and (2) Flat Washers		Included with clip angles (multi-section high assemblies only)
F-3	Anchor to Condition (varies)		Supplied by others

NOTE: Dimensions in parentheses () are millimeters.
Information is subject to change without notice or obligation.

Sill Flashing (if applicable)

1. Locate all sill flashing (by others or optional by Pottorff). Sill flashing is recommended for all multiple section louvers.
2. Confirm that the sill of the opening and the underside of the sill flashing are clean and free of all debris.
3. Apply caulk to the bottom of the opening and firmly set the sill flashing in the caulk. See Figure 1.1.
 - a. For wider openings, multiple pieces of flashing may be necessary in order to cover the entire width. When this occurs, caulk at all overlapping joints and firmly set. See Figure 1.2.
 - b. Closed end flashing pieces (if supplied by Pottorff) will include extra length on each end which must be cut and manually bent into place to close off the sill flashing ends. Carefully bend up the end tabs and thoroughly caulk the corner seams. See figure 1.3.

Single Section Louver Installation

1. Locate all A-1 anchor clip angles as required to establish proper louver depth and position. See fig. 2.1 for required locations and spacing. (Clip angles are by others or optional by Pottorff.)
2. Place the louver section into the opening. See fig. 2.2, 2.3, 2.4 and 2.5.
3. Shim around the perimeter of the louver to maintain the proper sealant joint clearance and to level the louver. (Shims are by others, or supplied by Pottorff along with clip angles.) Secure clip angles to wall structure using anchors (by others) as appropriate for the type of substrate.
4. When the louver is level and in the proper position, fasten louver frame to clip angles with minimum #12 screws (by others, or supplied by Pottorff along with clip angles.) Secure clip angles to wall structure using anchors by others as appropriate for the type of substrate.
5. Install backer rod and caulk around the entire perimeter of the louver. **Do not caulk between sill flashing and louver to allow for drainage.**

Multiple Section Louver Installation

1. Locate all A-1 anchor clip angles as shown in fig. 3.1 (Clip angles are by others or optional by Pottorff).
2. Install the lower left section (as viewed from the exterior) following steps 2-4 for single sections above. After this, if more than one section wide, install the next section to the right, following the procedure in steps 2-4 above. Moving from left to right and then bottom to top, install remaining sections and secure with clip angles as shown. See fig 3.1 and 3.4. At horizontal splice joints (if present), use A-2 extended angles to connect to a structural member (by others) behind the louver. For these splice connections see fig. 3.2 for mullion joints and fig. 3.3 for joints between stiffeners.
3. For hidden mullions, install gasket or sealant (by others) between mating stiffener angles. See fig. 3.5.
4. Install backer rod and caulk around the entire perimeter of the louver, and between louver sections, as required. **Do not caulk between louver and sill flashing to allow for drainage.**

Installation Details

Extruded Aluminum Stationary Louver Installation Instructions

Sill Flashing

Fig 1.1 Sill Flashing Vertical Section

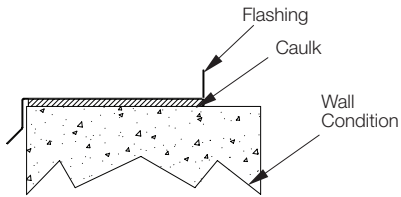

Fig 1.2 Sill Flashing Assembly

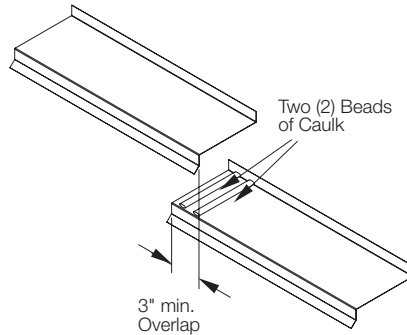
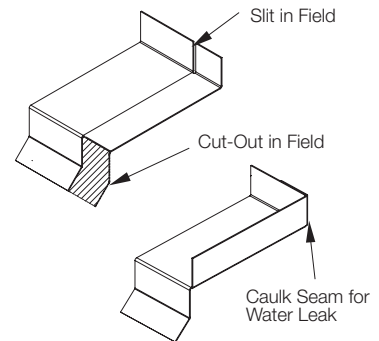

Fig 1.3 Closed End Sill Flashing



Single Section Louver Installation

Fig 2.1 Clip Angle - Single Section Louver

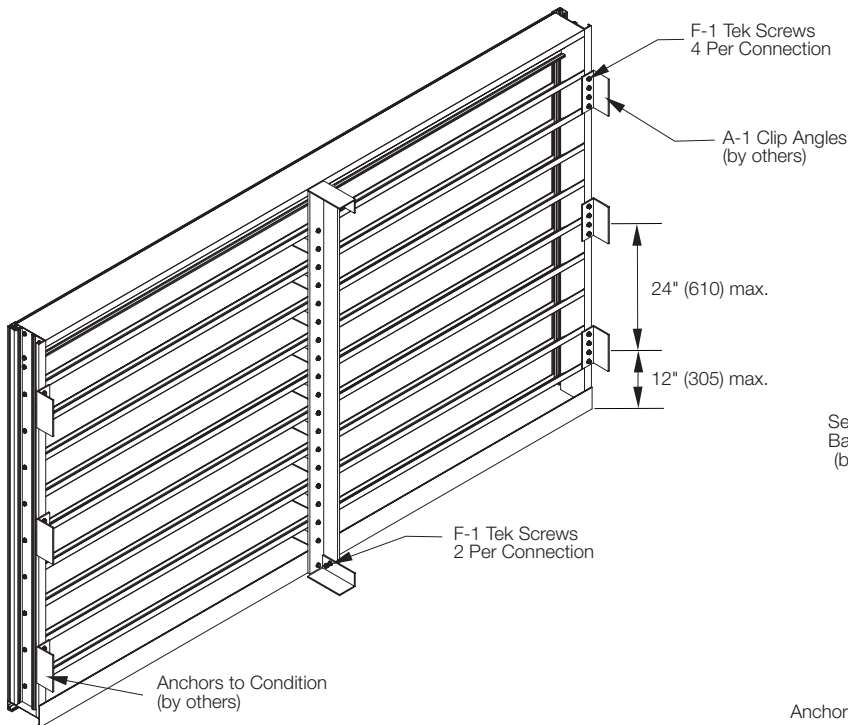

Fig 2.3 Stiffener

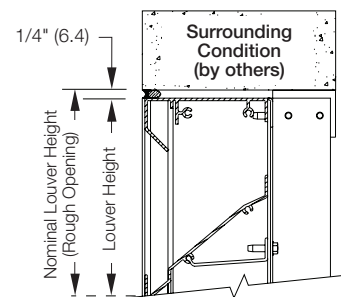

Fig 2.4 Jamb

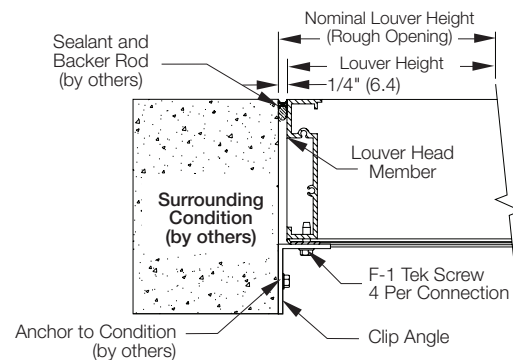

Fig 2.2 Head

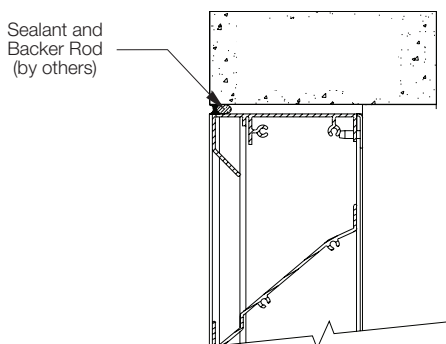
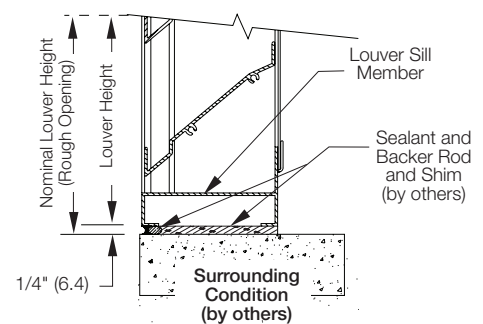

Fig 2.5 Sill



Installation Details

Extruded Aluminum Stationary Louver

Installation Instructions

Multiple Section Louver Installation

Fig 3.1 Clip Angle - Multiple Section Louver

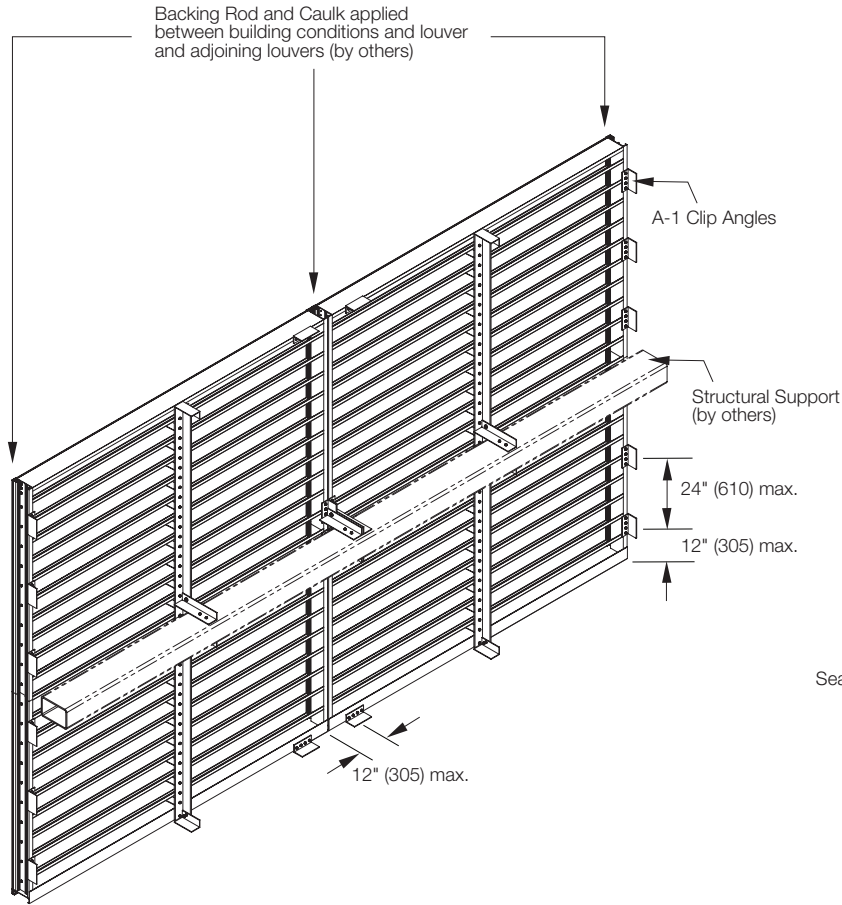

Fig 3.3 Stiffener Splice

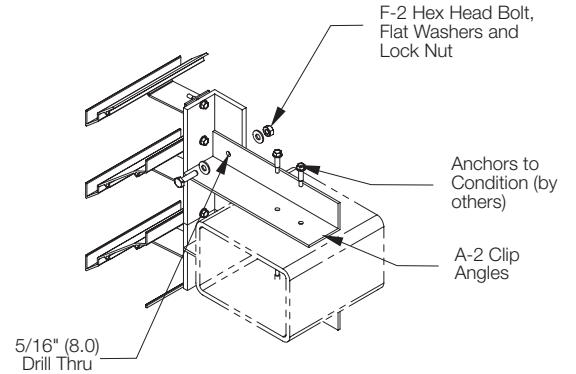

Fig 3.4 Visible Mullion

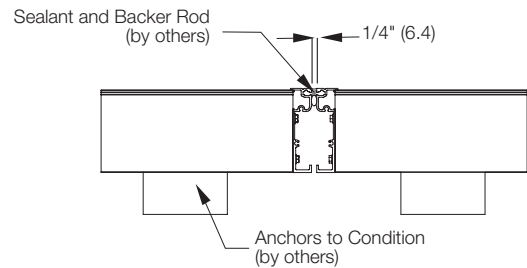

Fig 3.2 Jamb Splice Mullion

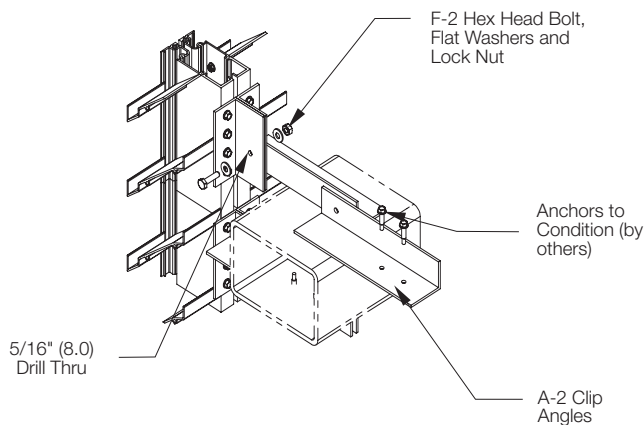
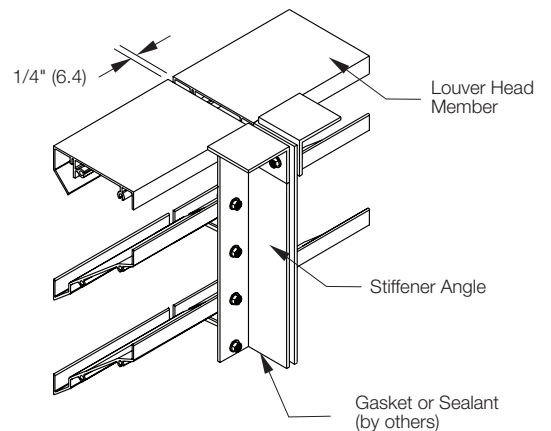

Fig 3.5 Hidden Mullion



MECHANICAL AND FINISH MAINTENANCE

Mechanical maintenance must be performed on louvers as a means of maintaining their performance, by carrying out the actions listed below. These maintenance steps should be performed once every three (3) months, as a minimum, but may be performed as frequently as every day.

All paint finished product must be inspected for evidence of unusual atmospheric residue every three (3) months. Should there be evidence of any such material or residue, clean it off immediately with a mild soapy solution and thoroughly rinse with clear water afterward. POTTORFF recommends a gentle cleaning of the louver surfaces once every three (3) months with a mild soapy solution followed immediately by rinsing with clear water.

Standard Louver Maintenance

- Inspect the perimeter caulking between the louver frame and its condition. Repair any visible holes or cracks.
- Inspect the blade drains for any foreign material that may have become lodged there, and remove it.
- Inspect the vertical jamb gutters for any foreign material that may have become lodged there, and remove it.
- Inspect the louver blade ends for any that may have become separated or forced away from its jamb and contact the factory for a maintenance person.

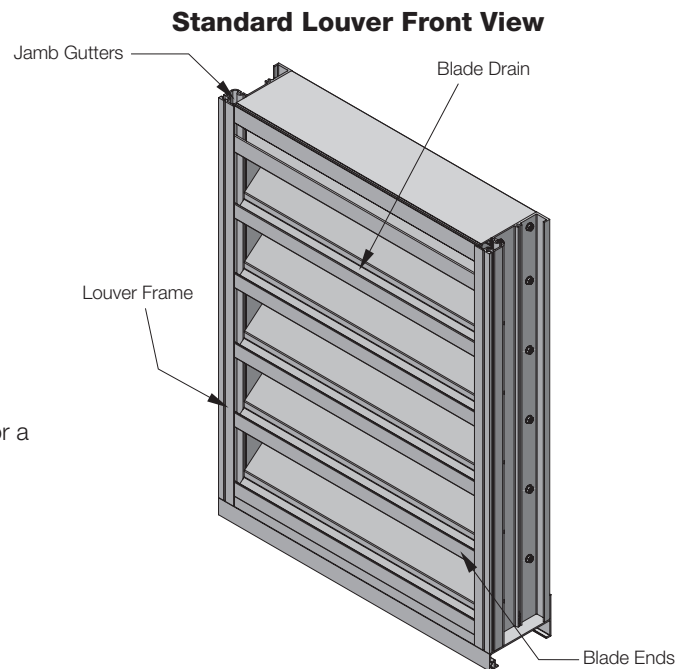

Operable Louver Rear View

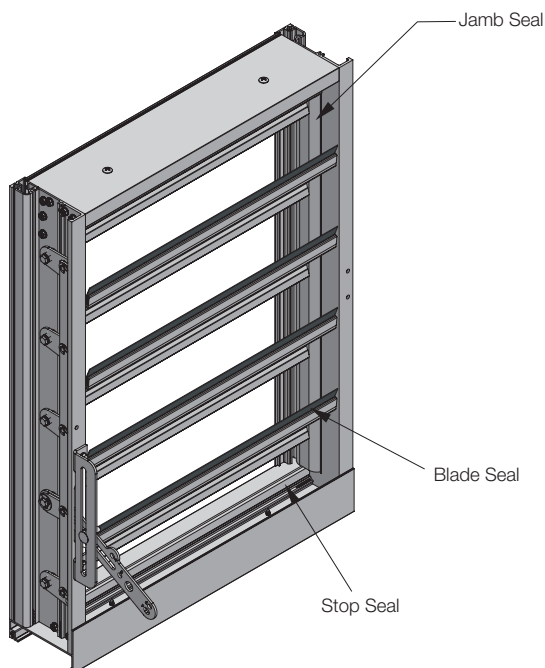

Operable Louver Maintenance

- Where applicable, follow all procedures listed above for standard louver maintenance.
- If applicable, inspect blade seals for any rips, tears or deformities.
- If applicable, inspect jamb seals for kinks or other deformities.
- If applicable, review actuator manufacturers O&M manual regarding actuator maintenance.
- If issues with any of the above, please contact the manufacturer directly.



Submittal # 85094

APPROVAL REQUIRED

Project 22104386-MECH-1- Brampton Victoria Park Arena
Leader Nevin Wong
Job Site Brampton Victoria Park Arena
Submission Date 2025-01-29
Sold To CONSULT MECH
Submitted By Lindsay Grahame

Contacts

Role	Customer	Contact	Our Rep
General Contractor	Rafat General Contracing Inc		
Mechanical Contractor	Con-Sult Mechanical Inc.*	Mohammed Ali Khan Lodhi	Nevin Wong
Mechanical Contractor	Con-Sult Mechanical Inc.*	Paul Leddy	Nevin Wong
Designer	WSP MMM Group		Alex Forsea

Deliverables

Track #	289042		
Tag	MD		
Description	Control Dampers		
Manufacturer	Alumavent		
Production Lead Time	6 - 8 weeks		
Revision #	0		

Notes:

Contractor to confirm size, quantities, frame type and blade orientation prior to ordering.

Lead times are estimated and subject to change on short notice

Attention:

- 1) HTS will provide equipment in accordance with the attached shop drawings.
- 2) Upon approved submittal and customer release, HTS will release equipment to fabrication per the published lead times. Any storage fees associated with project schedule changes will be the responsibility of the purchaser.
- 3) HTS can provide freight and logistics to the purchaser as an added benefit of doing business with HTS. When freight is received by the purchaser, any noticeable damage must be recorded. Otherwise, HTS is not responsible for subsequent damage claims.

Approval Stamps

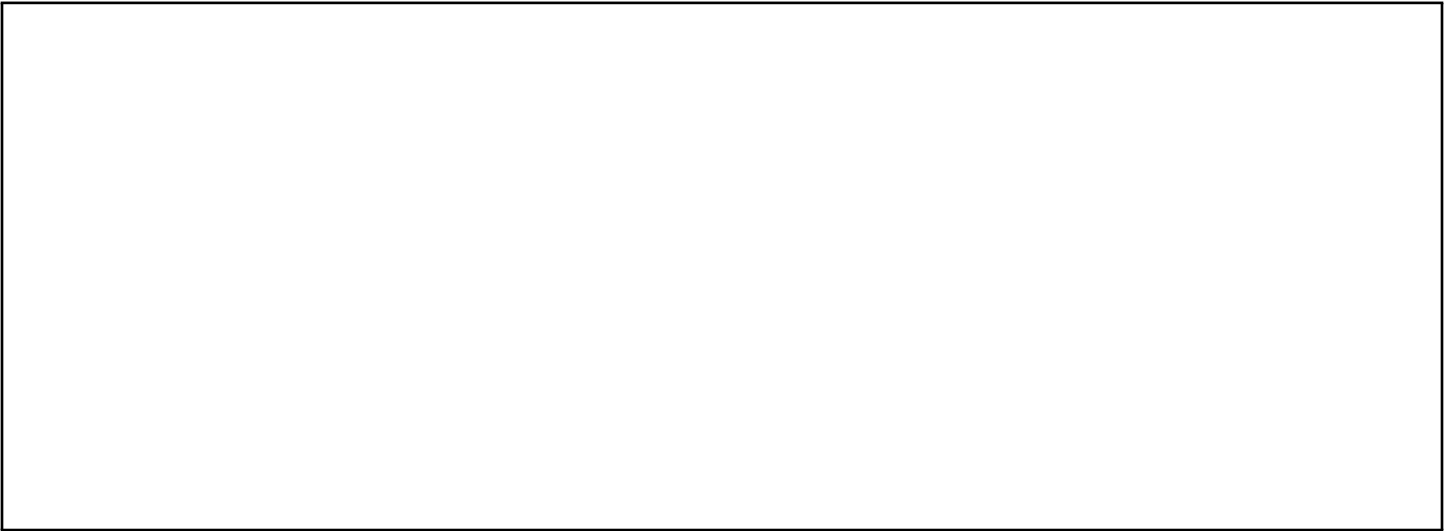
A large, empty rectangular box with a thin black border, intended for placing approval stamps. The box is currently blank.

Specifications

2.02 CONTROL DAMPERS AND OPERATORS

- .1 T. A. Morrison & Co. Inc. "TAMCO" 100 mm (4') deep, flanged, AMCA low leakage certified aluminium dampers. Dampers for modulating and mixing applications are to be opposed blade type. Dampers for open-shut service are to be parallel blade type. Maximum blade length is to be 1 m (4'). Dampers greater than 2 sections wide are to be complete with jackshaft. Each damper is to be complete with:
 - .1 extruded 6063T5 aluminum frame and airfoil blades, each with an integral slot to receive a gasket;
 - .2 extruded TPE frame gaskets and extruded EPDM blade gaskets;
 - .3 slip-proof aluminium and corrosion resistant plated steel linkage of metal thickness to prevent warping or bending during damper operation, concealed in frame, equipped with self-sealing and self-lubricating bearings consisting of Celcon inner bearing fixed on hexagonal blade pin and rotating in polycarbonate outer bearing inserted in frame.
- .2 For standard damper(s), Series 1000 as above.
- .3 For insulated damper(s), Series 9000 as above but with all 4 sides of frame insulated with polystyrene, and blades thermally broken and insulated with expanded polyurethane foam.
- .4 For stainless steel dampers, as above but constructed of type 316 stainless steel and equipped with Teflon blade bearings.

Motorized Dampers



3100 SERIES
AIRFOIL BLADE • EXTRUDED ALUM. CONTROL DAMPERS
3160 | 3161 | 3165

Contractor to confirm mounting

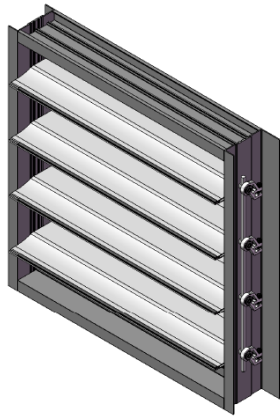

3160
Duct-Mount

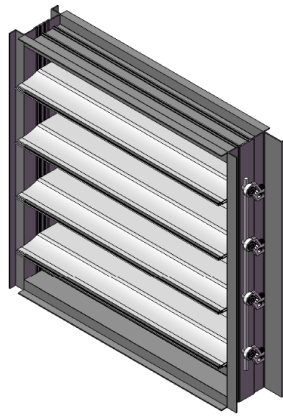

3161 Quick 'N' Stall
Duct-Mount

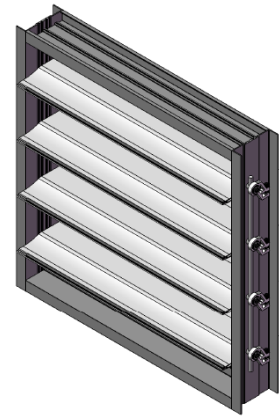

3165
Flanged-to-Duct

STANDARD CONSTRUCTION

Frame Depth: 4" (102 mm) – 3160/3165
5.25" (133 mm) – 3161
Overall Depth with Blades Open: 6.125" (156 mm)
Minimum Height: 8" (203 mm) - Single Blade
15" (381 mm) - Multiple Blade
Maximum Panel Width: 48" (1219 mm)
Maximum Panel Height: 60" (1524 mm)
Maximum Panel Size: 20 Sq.Ft.
Maximum System Pressure: See chart on page 2.
Operating Temperature Range: -40° to +180° F
Standard Finish: Mill extruded aluminum.
Standard Motor Installation: 6" Side Shaft Direct Drive
Linkage: Concealed in Frame (3160/3161)
Outside of Frame (3165)
Blade End Cap: Nylon

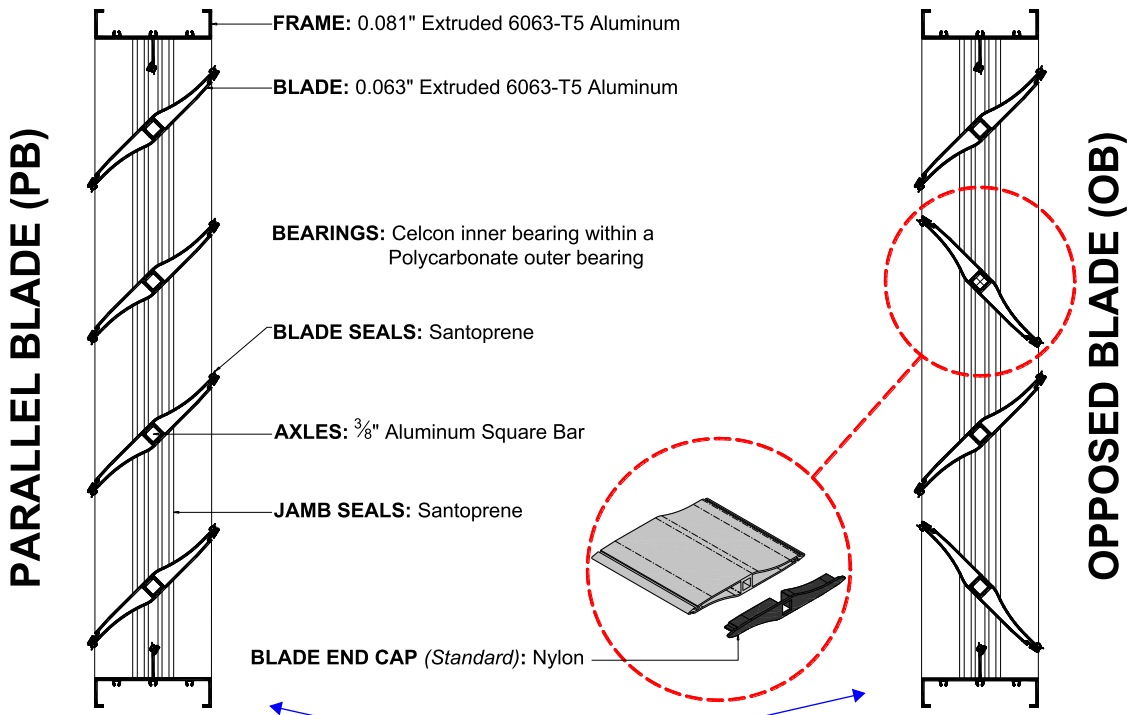

Contractor to confirm blade orientation.



3100 SERIES
AIRFOIL BLADE • EXTRUDED ALUM. CONTROL DAMPERS
3160 | 3161 | 3165

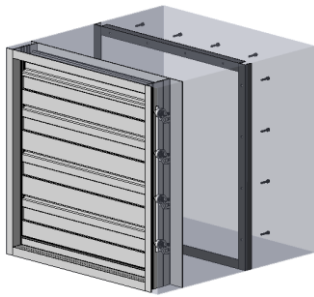

3160 – Duct-Mount

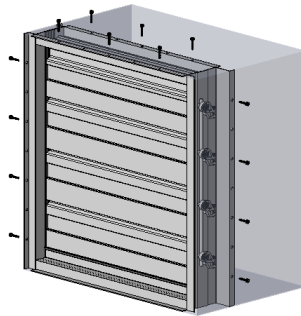

3161 – Duct-Mount

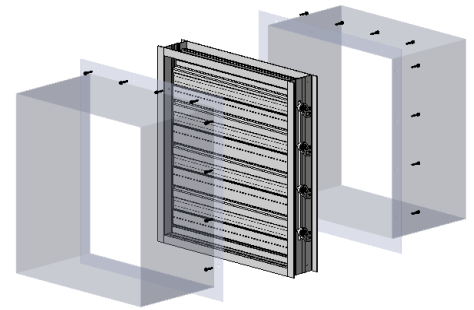

3165 – Flanged-to-Duct

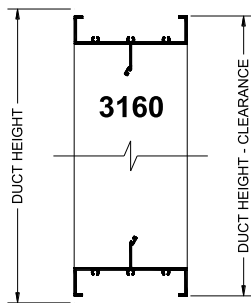

For Duct-Mount Frame specify: 3160 / 3161
For Flanged-to-Duct Frame specify: 3165

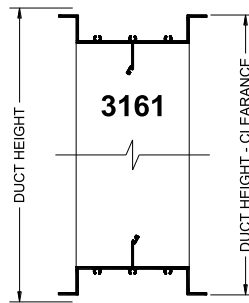

*For Models 3160 and 3161:

Clearance = 1/4" Overall for Single Panel Construction
Clearance = 1/2" Overall for Multiple Panel Construction

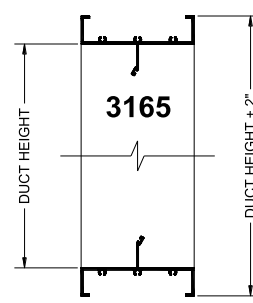

PRESSURE LIMITATIONS:

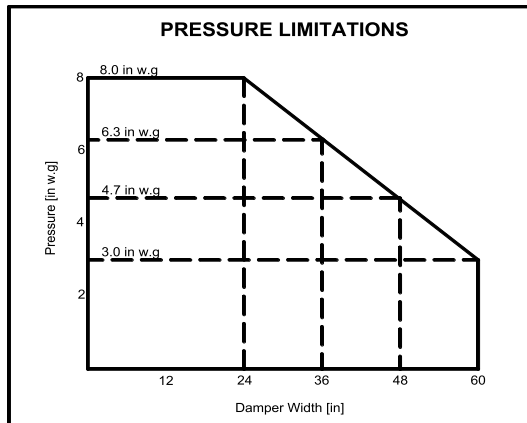

LEAKAGE DATA:

MAXIMUM DAMPER WIDTH	LEAKAGE CLASS (Opposed Blade Only)		
	@1" w.g. (0.25 kPa)	@4" w.g. (1 kPa)	@8" w.g. (2 kPa)
48" (1219 mm)	1A	1	1

Leakage Class definitions:

The maximum permitted leakage for Class ratings is as follows:

Class 1A: 3 cfm/ft² @ 1" w.g. (Class 1A is only tested at 1" w.g. per AMCA).

Class 1: 4 cfm/ft² @ 1" w.g.

8 cfm/ft² @ 4" w.g.

11 cfm/ft² @ 8" w.g.

Air leakage is based on operation between 0°C-49°C (32°F-120°F).

Data corrected to standard air density of 0.075 lbs./ft³.

Leakage tested in accordance with AMCA Standard 500-D, Fig.5.4A.

Data are based on a torque of 16 in.-lbs./ft² (1.81 N·m) to close and seat the damper during the test.



PRESSURE DROP:

Tested to AMCA Figure 5.3 (Ducted both sides):

12 x 12 (305 x 305)		24 x 24 (610 x 610)		36 x 36 (914 x 914)		48 x 12 (1219 x 305)		12 x 48 (305 x 1219)	
Velocity (fpm)	Pressure Drop (in. w.g.)	Velocity (fpm)	Pressure Drop (in. w.g.)	Velocity (fpm)	Pressure Drop (in. w.g.)	Velocity (fpm)	Pressure Drop (in. w.g.)	Velocity (fpm)	Pressure Drop (in. w.g.)
505	0.011	518	0.008	496	0.004	499	0.007	499	0.005
1001	0.040	990	0.028	1004	0.020	1003	0.027	1004	0.021
1463	0.091	1497	0.061	1495	0.043	1498	0.062	1504	0.048
1958	0.174	2010	0.103	1994	0.070	2002	0.116	2006	0.086
3004	0.422	3016	0.237	3001	0.165	3003	0.267	3001	0.197

Tested to AMCA Figure 5.5 (Inlet chamber, no outlet duct):

12 x 12 (305 x 305)		24 x 24 (610 x 610)		36 x 36 (914 x 914)		48 x 12 (1219 x 305)		12 x 48 (305 x 1219)	
Velocity (fpm)	Pressure Drop (in. w.g.)	Velocity (fpm)	Pressure Drop (in. w.g.)	Velocity (fpm)	Pressure Drop (in. w.g.)	Velocity (fpm)	Pressure Drop (in. w.g.)	Velocity (fpm)	Pressure Drop (in. w.g.)
489	0.051	531	0.055	496	0.045	572	0.052	608	0.086
996	0.196	1013	0.205	1004	0.185	1217	0.248	1241	0.359
1495	0.435	1513	0.467	1497	0.411	1795	0.558	1781	0.737
1986	0.767	2019	0.846	1999	0.741	2443	1.083	2443	1.393
3036	1.805	3004	1.887	3005	1.681	3014	1.758	3001	2.105

Pressure drop tested per AMCA 500-D per set-up figures as indicated above.
 Data corrected to standard air density of 0.075 lbs/ft³.

Alumavent Inc. certifies that
 the Model 3100 shown herein
 is tested in accordance with
 AMCA Publication 500-D.

RECOMMENDED SPECIFICATION:

Furnish and install control damper model 3160 / 3161 / 3165 as manufactured by Alumavent Inc., Bolton Ontario. Blades shall be 0.063" (1.60 mm) thick extruded aluminum, hollow airfoil shape. Frames shall be 0.081" (2.06 mm) thick extruded aluminum. Axles shall be 0.375" (9.53 mm) aluminum square bar. Blade and Jamb seals shall be Santoprene (or optional Silicone). Linkage is concealed in frame for models 3160 / 3161 and outside of frame for model 3165. Operating temperature range shall be -40° to +180°F. Leakage and pressure drop performance data submitted to be based on tests in accordance with AMCA Standard 500-D. Damper widths from 12" (305 mm) to 48" (1219 mm) must meet leakage Class 1A criteria of maximum 3 cfm/ft² (15.2 L/s/m²) at 1" w.g. (.25 kPa).

The Alumavent 3900 series thermally broken insulated blade aluminum control damper offers greater thermal efficiency than other control dampers. It features AMCA certified performance for Air Leakage, Air Performance and Thermal Efficiency.

Contractor to confirm mounting



3960
Duct-Mount



3961 Quick 'N' Stall
Duct-Mount



3965
Flanged-to-Duct



3967
Front Flanged

STANDARD CONSTRUCTION

- Depth:** 4" (102 mm) – 3960/3965/3967
5.25" (133 mm) – 3961
- Depth with Blades Open:** 6.125" (156 mm)
- Minimum Height:** 6" (152 mm) - Single Blade
15" (381 mm) - Multiple Blade
- Maximum Panel Width:** 48" (1219 mm)
- Maximum Panel Height:** 60" (1524 mm)
- Maximum Panel Size:** 20 Sq.Ft.
- Maximum System Pressure:** Up to 8 in.wg. (1.99 kpa) see chart
- Maximum Velocity:** Up to 4000 fpm (20 m/s)
- Operating Temperature Range:** -40° to +180° F
- Thermal Efficiency:** 378%
- Standard Finish:** Mill
- Standard Motor Installation:** 6" Side Shaft Direct Drive
- Linkage:** Concealed in Frame (3960/3961)
Outside of Frame (3965/3967)

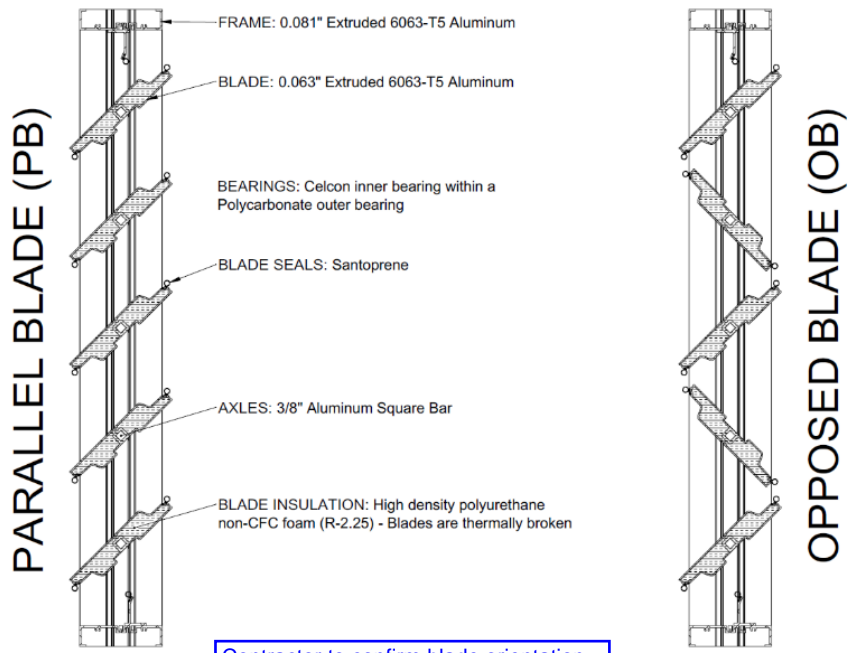

Contractor to confirm blade orientation.

DWG. 3960-3961-3965-3967 NOV 2024

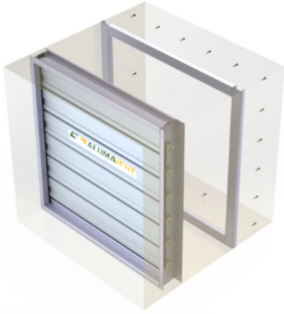

3960
*Duct-Mount Requires
Mounting Angle*

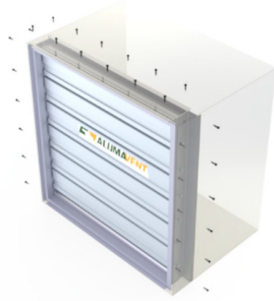

3961 Quick 'N' Stall
Duct-Mount

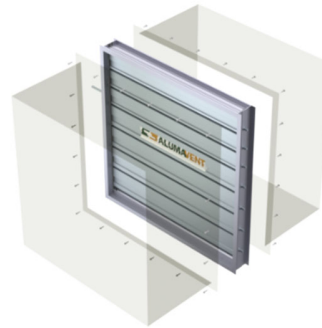

3965
Flanged-to-Duct

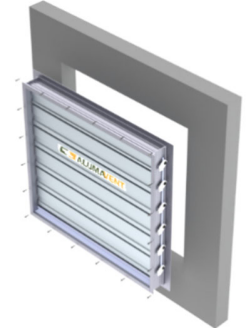

3967
Front Flanged

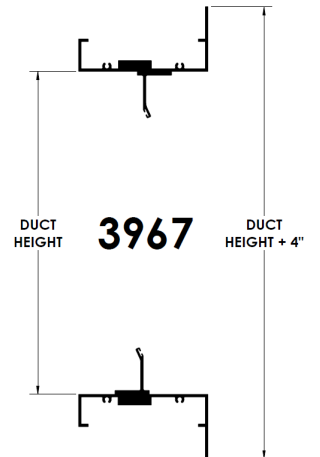
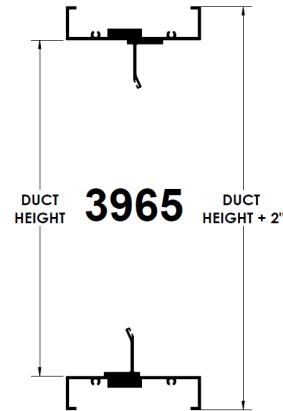
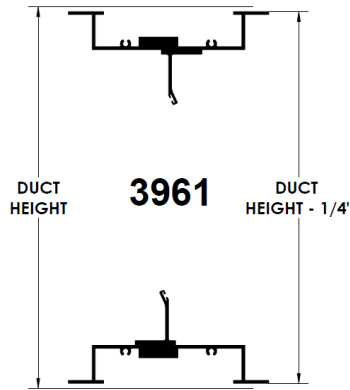
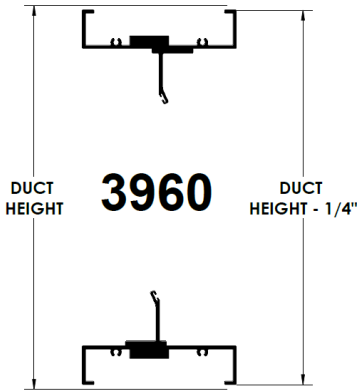

RECOMMENDED SPECIFICATION

Furnish and install control damper models 3960 / 3961 / 3965 / 3967 as manufactured by Alumavent Inc., Alliston Ontario. Damper must be licensed to bear the AMCA seal for Air Leakage, Air Performance and Thermal Efficiency. Blades shall be 0.063" (1.60 mm) thick, thermally broken with high density Polyurethane non-CFC injected foam insulation. Frame shall be a extruded aluminum with a minimum wall thickness of 0.081" (2.06 mm) thick. Axles shall be 0.375" (9.53 mm) thick, aluminum square bar. Blade and jamb seals shall be extruded santoprene. Linkage is concealed in frame for models 3960 / 3961 and outside of frame for model 3965. Air leakage shall not exceed 3 CFM/ft² (15.2 L/s/m²) against 1" w.g (0.25 kPa) static pressure at standard air (as per AMCA testing). Operating temperature range shall be -40° to +180° F.

AMCA 5.2

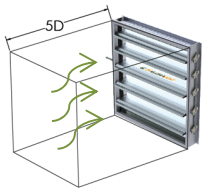
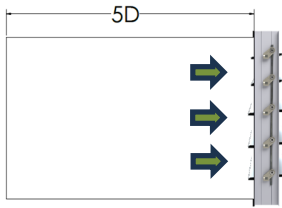

AMCA 5.3

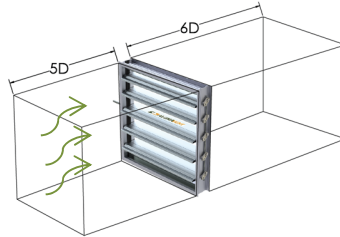
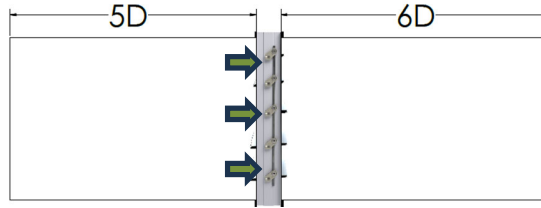

AMCA 5.5

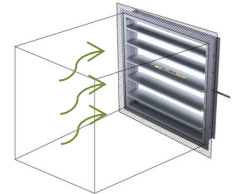
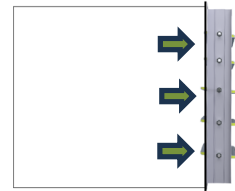

3900 SERIES CONTROL DAMPER PRESSURE DROP	
Velocity [FPM]	Pressure Drop [in. w.g.]
12x12 (inches)	
809	0.122
1003	0.182
1478	0.403
2462	1.105
3961	2.887
24x24 (inches)	
491	0.018
588	0.026
783	0.046
986	0.072
4005	1.192
36x36 (inches)	
705	0.035
1503	0.151
1990	0.261
2986	0.586
4239	1.197
12x48 (inches)	
518	0.087
993	0.341
1485	0.827
2486	2.308
3531	4.471
48x12 (inches)	
520	0.037
973	0.133
1469	0.306
2479	0.865
4026	2.1

3900 SERIES CONTROL DAMPER PRESSURE DROP	
Velocity [FPM]	Pressure Drop [in. w.g.]
12x12 (inches)	
802	0.049
1003	0.076
1473	0.171
2457	0.481
3955	1.264
24x24 (inches)	
494	0.006
579	0.009
787	0.017
980	0.026
4001	0.434
36x36 (inches)	
718	0.009
1504	0.063
1984	0.117
2991	0.255
4242	0.547
12x48 (inches)	
505	0.06
993	0.232
2001	0.971
2995	2.242
3586	4.06
48x12 (inches)	
516	0.016
988	0.057
1494	0.125
2488	0.351
4006	0.884

3900 SERIES CONTROL DAMPER PRESSURE DROP	
Velocity [FPM]	Pressure Drop [in. w.g.]
12x12 (inches)	
818	0.173
1017	0.264
1492	0.572
2481	1.570
3970	4.100
24x24 (inches)	
490	0.049
1786	0.672
2782	1.645
3474	2.556
3967	3.328
36x36 (inches)	
486	0.045
1495	0.458
2387	1.187
3183	2.110
3873	3.184
12x48 (inches)	
493	0.061
1482	0.584
2383	1.524
3175	2.771
3854	4.178
48x12 (inches)	
501	0.054
1487	0.498
2386	1.318
3180	2.333
3963	3.702

DEFINITION OF LEAKAGE CLASSIFICATION				
CLASS	LEAKAGE ft ³ /min/ft ² (L/s/m ²)			
	1" (0.25 kPa)	4" (1.0 kPa)	8" (2.0 kPa)	12" (3.0 kPa)
1A	3 (15.2)	N/A	N/A	N/A
1	4 (20.3)	8 (40.6)	11 (55.9)	14 (71.1)
2	10 (50.8)	20 (102)	28 (142)	35 (178)
3	40 (203)	80 (406)	112 (569)	140 (711)

3900 SERIES CONTROL DAMPER LEAKAGE RATING			
DAMPER SIZE Width x Height	PRESSURE in w.g (kPa)		
	1" (0.25 kPa)	4" (1.0 kPa)	8" (2.0 kPa)
12" x 12" (305x305 mm)	1A	1	1
24" x 24" (610x610 mm)	1A	1	1
36" x 36" (914x914 mm)	1A	1	1
12" x 48" (305x1219 mm)	1A	1	1
48" x 12" (1219x305 mm)	1A	1	1
36" x 48" (914x1219 mm)	1A	1	1

Leakage test was conducted in accordance with AMCA Standard 500-D, Fig.5.4A.

Data are based on a torque of 10.625 in.-lbs./sq.ft (1.3 N•m) to close and seat the damper during the test. Air leakage is based on operation between 0°C-49°C (32°F-120°F). Data corrected to standard air density of 0.075 lbs./ft.³.

AMCA Certified Energy Efficiency Performance

Alumavent Inc. 3900 insulated control Damper has a Thermal Efficiency Ratio of 378%

A damper's Thermal Efficiency Ratio (E) is a comparison of the thermal performance of the tested damper with that of a standard reference damper, which is a 3V blade damper with blade and jamb seals. A damper with the same thermal efficiency as the reference damper would have an E of 100%. A damper that is twice as efficient as the reference damper would have an E of 200%. A damper that is three times as efficient as the reference damper would have an E of 300%. A damper that is four times as efficient as the reference damper would have an E of 400%. A damper that is five times as efficient as the reference damper would have an E of 500%. A damper that is six times as efficient as the reference damper would have an E of 600%. A damper that is seven times as efficient as the reference damper would have an E of 700%. A damper that is eight times as efficient as the reference damper would have an E of 800%. A damper that is nine times as efficient as the reference damper would have an E of 900%. A damper that is ten times as efficient as the reference damper would have an E of 1000%.

Test Information

Testing was conducted on a 36 in. x 36 in. (914mm x 914mm) sample in AMCA 500-D11 Damper Efficiency Test Report figure 5.10 per AMCA standard 500-D's Thermal Efficiency test.

Torque

Data are based on a torque of 72 in.lb./ft² (8.1 N•m) applied to close and seat the damper during the test.



3900 Installation Instructions



Jack Shaft Assembly Instructions



Jumper Assembly Instruction



Certification

CERTIFIED RATINGS

Alumavent Inc. certifies that the 3900 Series Insulated Control Dampers shown here are licensed to bear the AMCA Seal. The ratings shown are based on tests and procedures performed in accordance with AMCA Publication 511 and comply with the requirements of the AMCA Certified Ratings Program. The AMCA Certified Ratings Seal applies to Air Performance, Air Leakage and Thermal Efficiency ratings.



Damper configuration

CONFIGURATION | 11L | 11R

- **SINGLE PANEL**
- Maximum Width 48"
- Maximum Height 60"
- Maximum 20 sq ft.
- Standard LEFT drive (11L)

Option:
1. RIGHT drive (11R)

Standard
* One actuator

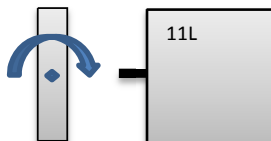

Option 1.
* One actuator

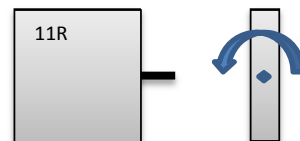

CONFIGURATION | 21B | 21L | 21R

- **DOUBLE PANELS**
- Maximum Width 96"
- Maximum Height 60"
- Maximum 40 sq ft.
- Standard Drive on Both hands (21B).

Option:
1. Up to 20 sq ft: Jumper bracket
2. Over 20 sq ft: LEFT drive (21L). Requires jack shaft.
3. Over 20 sq ft: RIGHT drive (21R). Requires jack shaft.

Standard
* Two actuators



Option 1.
* One actuator min.

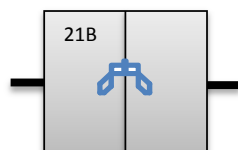

Option 2.
* One actuator min.

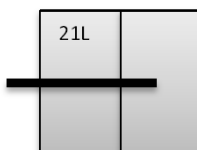

Option 3.
* One actuator min.

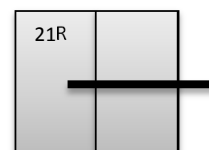

CONFIGURATION | 31L | 31R

- **TRIPLE PANELS**
- Maximum Width 144"
- Maximum Height 60"
- Maximum 60 sq ft.
- Standard LEFT Drive (31L).

Option:
1. Standard LEFT Drive (31L) requires optional jack shaft type A
2. RIGHT Drive (31R), requires optional jack shaft type A

Option 1.
* Jack shaft Type A
* One actuator min.

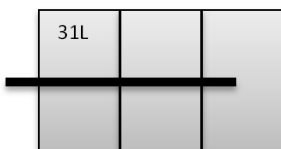

Option 2.
* Jack shaft Type A
* One actuator min.

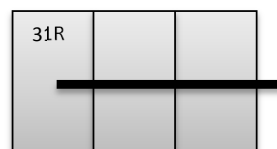

CONFIGURATION | 41B

- **QUADRUPLE PANELS**
- Maximum Width 192"
- Maximum Height 60"
- Maximum 80 sq ft.
- Standard LEFT Drive (41B).

Option:
1. Up to 40 sq ft: LEFT and RIGHT Drive (41B), requires two Jumper bracket
2. Over 40 sq ft. LEFT and RIGHT Drive (41B), requires two jack shaft type A

Option 1.
* Two jumper brackets
* Two actuators min.

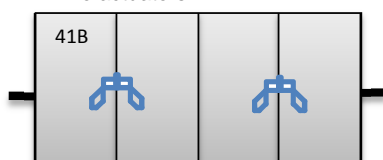

Option 2.
* Two Jack shaft Type A
* Two actuators min.

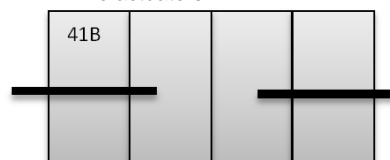

Damper configuration

CONFIGURATION | 12L | 12R

- DOUBLE PANELS HEIGHT

- Maximum Width 48"
- Maximum Height 120"
- Maximum 40 sq ft.
- Standard LEFT Drive (12L)

Option:

1. RIGHT Drive (12R).
2. LEFT Drive (21L), with Vertical Jack shaft type D.
3. RIGHT h (21R), with Vertical Jack shaft type D.

Standard

- * Two actuators

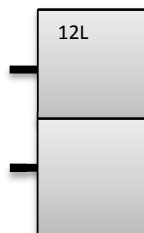

Option 1.

- * Two actuators

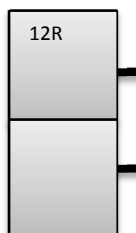

Option 2.

- * Jack shaft Type D
- * One actuator min.



Option 3.

- * Jack shaft Type D
- * One actuator min.

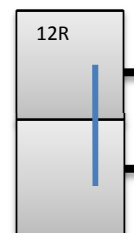

CONFIGURATION | 22B | 22L | 22R

- DOUBLE PANELS WIDTH/HEIGHT

- Maximum Width 96"
- Maximum Height 120"
- Maximum 80 sq ft.
- Standard Drive on BOTH sides (22B)

Option:

1. Up to 40 sq ft: LEFT or RIGHT Drive (22B), requires two Jumper bracket
2. Over 40 sq ft. LEFT Drive (22L), requires two jack shaft type A
3. Over 40 sq ft. RIGHT Drive (22R), requires two jack shaft type A

Standard

- * Four actuators

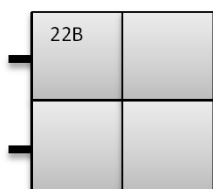

Option 1.

- * Two jumper brackets
- * Two actuators min.

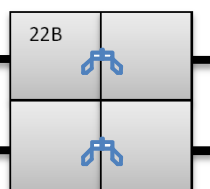

Option 2.

- * Two Jack shaft Type A
- * Two actuators min.

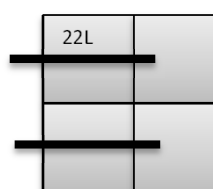

Option 3.

- * Two Jack shaft Type A
- * Two actuators min.

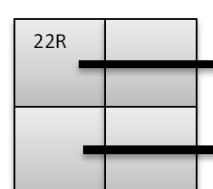

CONFIGURATION | 42B

- QUADRUPLE PANELS WIDTH DOUBLE HEIGHT

- Maximum Width 192"
- Maximum Height 120"
- Maximum 160 sq ft.
- Standard Drive on BOTH sides (42B)

Option:

1. Up to 80 sq ft: Drive on BOTH sides (42B), requires four Jumper brackets
2. Over 80 sq ft. Drive on BOTH sides (42B), requires four jack shaft type A

Option 1.

- * Four jumper brackets
- * Four actuators min.



Option 2.

- * Four Jack shaft Type A
- * Four actuators min.

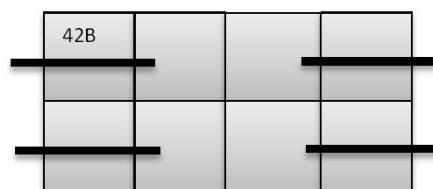

CONFIGURATION | 62B

- SIX PANELS WIDTH / DOUBLE HEIGHT

- Maximum Width 288"
- Maximum Height 120"
- Maximum 240 sq ft.
- Standard Drive on BOTH sides (62B)

Option:

1. Requires four jack shaft type A

Option 1.

- * Four Jack shaft Type A
- * Four actuators min.

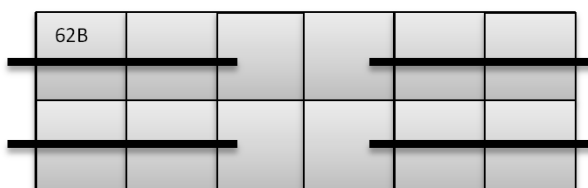

Installation

Operation

Maintenance

Installation, Operation and Maintenance Manual

3100, 3900, Series Control Dampers

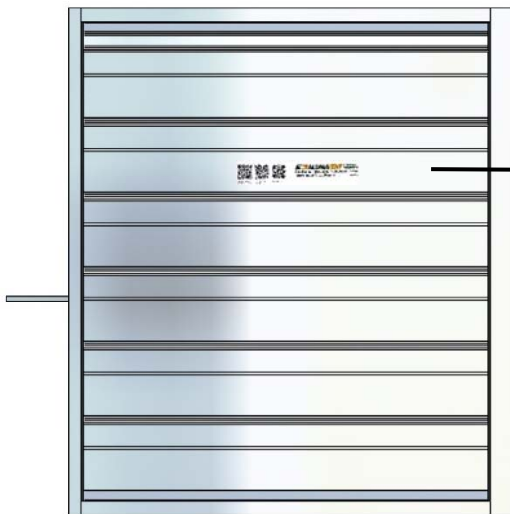
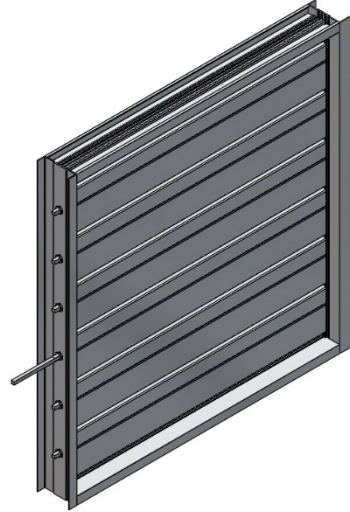

ALUMAVENT CONTROL DAMPERS
Customer Service: 1-800-668-7214
Factory Tested Torque Required: _____ In.-lbs

Safety Warning

Please read the installation, operation, and maintenance instructions in whole preceding to installing or servicing. Incorrect installation, adjustment, change, service, or maintenance can cause property damage, injury, or death.

Delivery and Handling

Once the dampers have been received, scan them for both visible and inconspicuous damage. If damage is discovered, **make a note of it on the bill of lading and proceed to file a claim with the transporter.** Verify that all elements of the package, including accessories, are accounted for and accurate.

Dampers need to be kept clean and dry at all times. It is highly advised that you store your dampers indoors and protect them from dirt, dust, damage, and natural elements.

Pre-Installation Guidelines

The goal of a suitable installation is to attach the control damper into the opening in such a way that damper action is not distorted or disrupted. The checklist below will help you complete the damper installation in a timely and efficient manner.

- 1) Review the schedules to see where the dampers should be installed in the building. Inspect the damper for any signs of damage and dirt.
- 2) When moving the damper, only use the frame or sleeve. Do not use the blades, linkage, actuators, or jackshafts to lift the damper as this could cause damage. Use enough support to raise each section mullion uniformly when handling multi section dampers (see drawing). Avoid excessive bending, twisting, or racking. The damper must not be dragged or stepped on.
- 3) Damper blades need to open and/or close properly. It is not recommended to install screws in the damper frame that interfere with the blade linkage and prohibit this.
- 4) When putting dampers in ducts or apertures they need to be square and not have any twists. Squeezing or stretching the damper into the duct or hole is NOT recommended. Dampers that experience excessive leakage and/or torque needs that exceed damper/actuator design might result from out of square, racked, twisted, or misaligned installations.
- 5) Before and after installation, the damper and actuator must be kept clean, dry, and free of debris, dust, and other foreign materials. Metal shavings, sand, drywall dust, fireproofing materials, plaster, and paint overspray are all examples of foreign materials.
- 6) If wall texturing or spray painting will be done within 10 feet (3 metres) of the damper, the damper should be adequately covered to prevent overspray. Needless dirt and debris on the damper can result in a higher chance of leakage and/or torque needs that are higher than the damper/actuator design.
- 7) In order to maintain, inspect, and service the dampers, appropriate access to dampers and actuators is needed. It will be required to install a removable section of duct if satisfactory size access cannot be accomplished.

Electrical Guidelines:

All electrical and or pneumatic connections to damper actuators should be made in accordance with applicable codes, ordinances and regulations according to region.

Safety Danger

An electrical input may be needed for this equipment. This work should be performed by a qualified electrician only.

Safety Caution

Please verify power requirements before wiring the actuator. Alumavent is not responsible for any damage to, or failure of the unit caused by incorrect field wiring. Electrical and/or pneumatic connections to damper actuators should be made in accordance with wiring and piping diagrams developed in compliance with applicable codes, ordinances and regulations.

Installation Instructions

IMPORTANT: Failure to follow instructions will void all warranties.

IMPORTANT: MODEL SERIES' 3100 AND 3900 DAMPERS WITH VISIBLE/EXPOSED SIDE BLADE LINKAGE INSTALLED IN OR NEAR EXTERIOR WALLS MUST BE INSTALLED WITH EXPOSED LINKAGE TOWARDS INTERIOR OF BUILDING.

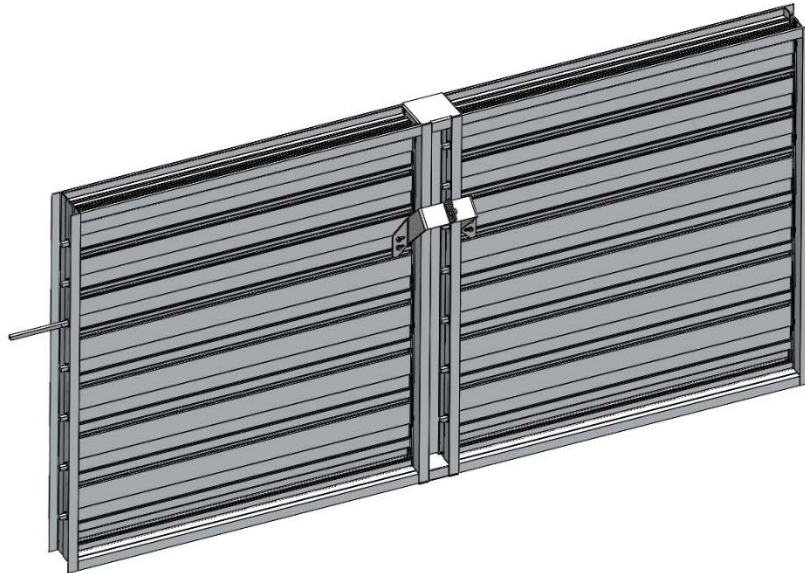

3965 Series shown with jumper and mullion end caps installed

Installation Instructions

See Jackshaft
Instructions



See Jumper
Instructions



The number of sections in a damper assembly is not limited, however they must not exceed the maximum section sizes listed below. Only the largest single piece of these dampers is designed to be self-supporting. Bracing may be required for multiple section damper assemblies to sustain the assembly's weight and keep it from collapsing under system pressure. To support the damper horizontally, Alumavent suggests suitable bracing (installer is responsible for suitable bracing). To avoid sagging due to damper weight, support ductwork in the area of the damper.

Damper Model Series – 3100 & 3900
Section Size – 48''w x 60''h (1219 x 1524)
Max. size for multi section dampers - unlimited

One Section Wide

Each damper section, including multi-section assemblies are required to be square without twisting, bending, or racking. Measure each segment diagonally from the upper corners to the opposite bottom corners.

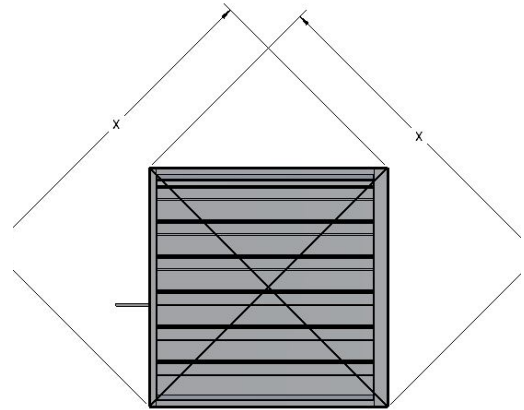

3961 Series

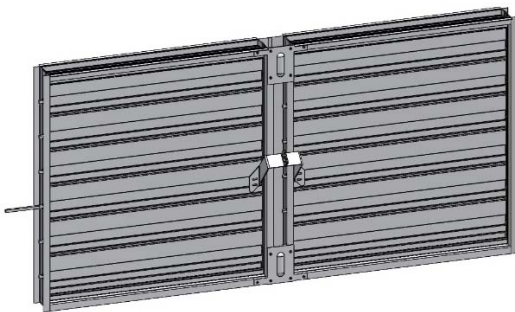

3960 series shown with jumper and multi section brackets installed.

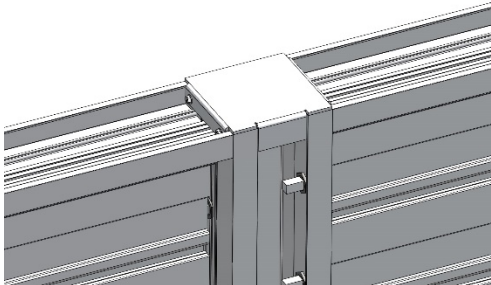

Two Section Wide

Frame members are designed to overlay. The offset overlaying frame comes with fasteners installed. The installer may require bracing. Ensure both sections are parallel, level, and straight to each other. To add strength, add multi-section brackets. Mullion end caps may be used when linkages are to be clear of dirt and debris

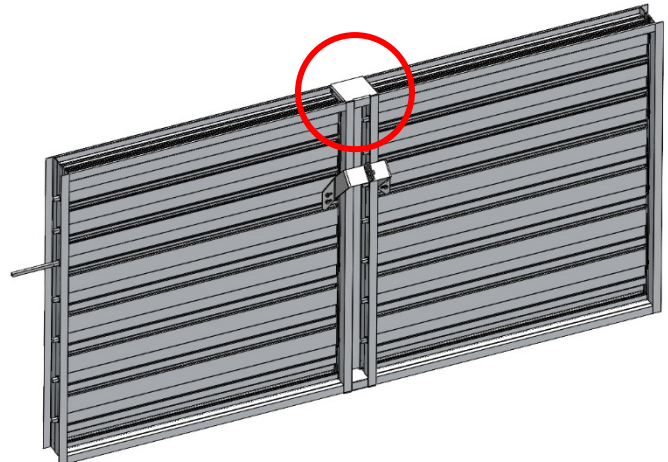

Series shown with mullion end caps. Follow multi section brackets and end cap instructions.

Multiple Section Wide

The bottom sections should be installed first. Set the second level of damper section(s) on top of the bottom section(s), taking into consideration the alignment of all pieces. The installer may require some bracing. It is important to ensuring both sections are straight, even, and parallel to each other. To add strength, use multi-section brackets. Mullion end caps may be used when linkages are to be kept free of dirt and debris (see two sections wide)

3965 Series shown with jumper

(See jumper instructions QR code)

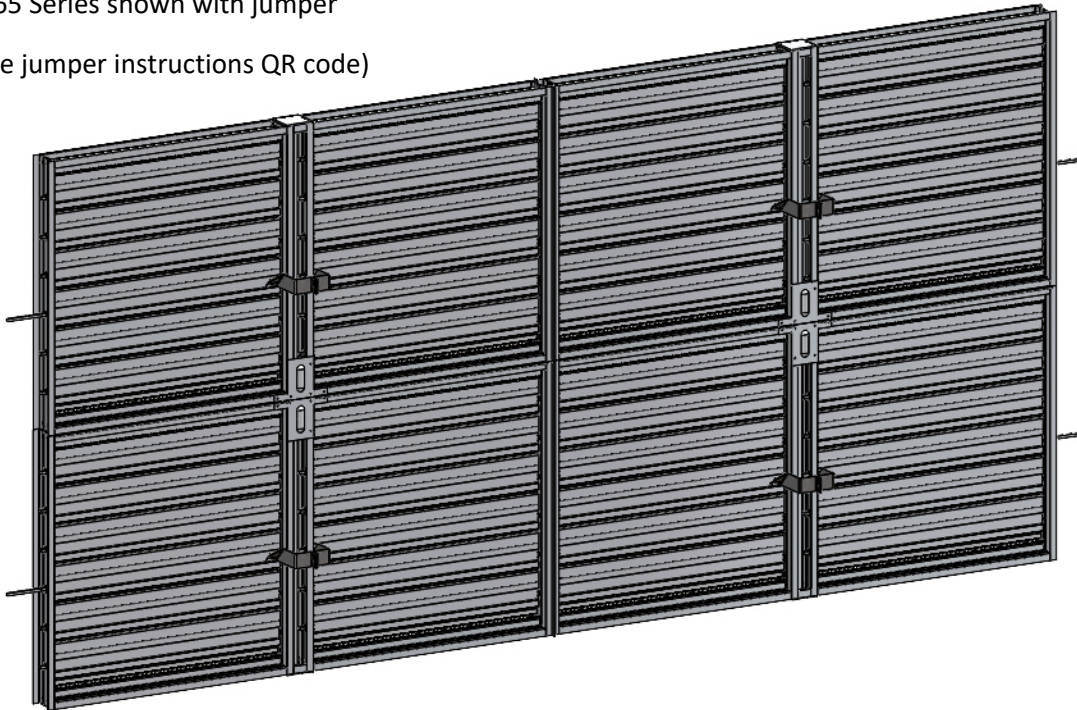

- 1) Shims shall be used between the damper frame and the duct aperture or opening gap to avoid the frame from being distorted by the bolts that hold it in line. To reinforce for strength, brace every horizontal mullion and every 8 feet of damper width vertically. High-velocity dampers (2000 fpm [10.2 m/s]) could require further bracing. Alumavent dampers are built and engineered specifically for structural integrity dependent on model and conditions. The **installer is responsible** for attaching, framing, mating flanges, and anchoring damper assemblies into apertures, ducting, or walls. **Field engineers** should determine the design calculations for these retaining and supporting that particular installation.
- 2) The extension pin should extend roughly 4-6 inches (102-152mm) beyond the frame if the damper actuator is to be installed out of the air stream. For jackshaft units, the jackshaft should extend through the jackshaft bearing assembly and approximately 6 inches (152mm) beyond the frame for jack shafted units.
- 3) Individual damper sections, as well as entire multi-section assemblies, need to be square and without racking, twisting, or bending. Measure each portion diagonally from the upper corners to the opposite bottom corners.
- 4) Damper blades, axles, and linkage must all function freely. Cycle dampers after installation to ensure good operation before starting the system. All portions of a multi-section assembly should open and close at the same time.

Operation:

Ensure that the blades open and close properly while running the damper through its full cycle. Check for slack linkage, especially at the actuator, if there is a problem. Tighten the linkage as required.

Closure:

Remove any unnecessary objects that could hinder blade closure or appropriate blade-to-blade or blade-to-frame seal.

Moving Parts:

Monitor those elements that are supposed to move freely, such as linkages, bearings, and blades, can. Lubricating these components helps to keep them from rusting and accumulating unnecessary friction over time. Only use Moli-spray oil or a related graphite-based dry lubricant since regular lubricating oil attracts dirt more easily. When using ball bearings (without grease fittings) and synthetic, oil-impregnated bearings lubrication is not necessary.

Foreign Matter:

Dirt and dirt can build up over time on damper surfaces. Wipe the damper surfaces with a non-oil-based mild solvent/cleaner to avoid impeding airflow and buildup of debris.

Damper Trouble Shooting:

The following is a cause and correction list for common concerns regarding damper operation:

Symptom	Possible cause	Corrective Action
Damper fails to fully open and/or fully close	Frame is cracked/out of square causing blades to bind on jamb seals	Adjust frame so that it is square and plumb within the duct/opening
	Linkage on actuator is loose	Close damper, disconnect power, adjust and tighten linkage
	Defective actuator	Replace actuator
	Screws in damper linkage	Locate screws and remove or relocate
	The linkage of the actuator is hitting the wall or floor	Damper installed too far into wall. Move out
	Contaminants on damper	Clean with a non oil-based mild solvent/cleaner
Actuator runs hot or makes a humming noise	Actuator prohibited from reaching end of stroke	Disconnect linkage from jackshaft, open damper, power actuator to end of spring, tighten linkage. Verify amperage draw

Warranty

Alumavent warrants this equipment to be free from defects in material and workmanship for a period of one year from the purchase date. Any units or parts which prove to be defective during the warranty period will be repaired or replaced at our option. Alumavent shall not be liable for damages resulting from misapplication or misuse of its products. Alumavent will not be responsible for any installation or removal costs. Alumavent will not be responsible for any service work or back charges without prior written authorization.

Submittal # 85095

APPROVAL REQUIRED

Project 22104386-MECH-1- Brampton Victoria Park Arena
Leader Nevin Wong
Job Site Brampton Victoria Park Arena
Submission Date 2025-01-29
Sold To CONSULT MECH
Submitted By Lindsay Grahame

Contacts

Role	Customer	Contact	Our Rep
Mechanical Contractor	Con-Sult Mechanical Inc.*	Inzaman Khan	Nevin Wong
General Contractor	Rafat General Contracing Inc		
Mechanical Contractor	Con-Sult Mechanical Inc.*	Mohammed Ali Khan Lodhi	Nevin Wong
Mechanical Contractor	Con-Sult Mechanical Inc.*	Paul Leddy	Nevin Wong
Designer	WSP MMM Group		Alex Forsea

Deliverables

Track #	289043		
Tag	VAV		
Description	Terminal Boxes		
Manufacturer	Nailor Industries		
Production Lead Time	9 - 11 weeks		
Revision #	0		

Notes:

Contractor to confirm size, quantities and handings prior to ordering.

Lead times are estimated and subject to change on short notice

Attention:

- 1) HTS will provide equipment in accordance with the attached shop drawings.
- 2) Upon approved submittal and customer release, HTS will release equipment to fabrication per the published lead times. Any storage fees associated with project schedule changes will be the responsibility of the purchaser.
- 3) HTS can provide freight and logistics to the purchaser as an added benefit of doing business with HTS. When freight is received by the purchaser, any noticeable damage must be recorded. Otherwise, HTS is not responsible for subsequent damage claims.

Approval Stamps

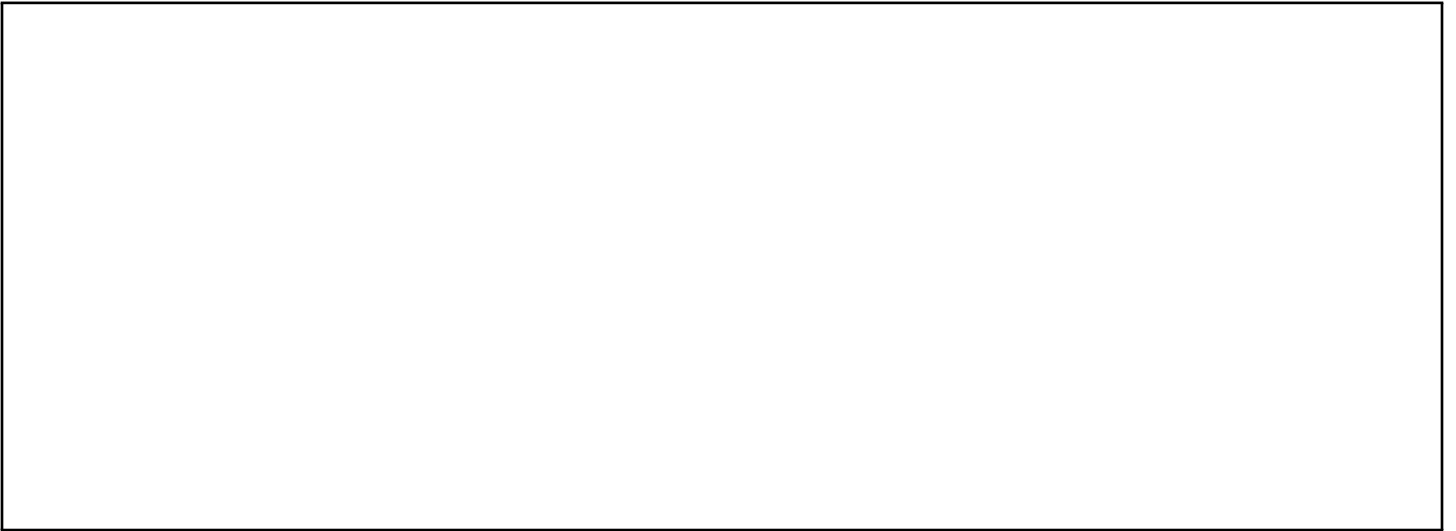
A large, empty rectangular box with a thin black border, intended for placing approval stamps. The box is currently blank.

Specifications & Schedule

2.01 VARIABLE AIR VOLUME (VAV) TERMINAL BOXES

- .1 Single duct, controller type, pressure independent variable air volume boxes in accordance with drawing schedule, each individually field adjustable to minimum and maximum air volumes, and complete with:
 - .1 #22 gauge galvanized steel housing, sealed and gasketed, and complete with:
 - .1 internally lined with 25 mm (1") thick glass fibre duct lining material with a neoprene coating meeting NFPA 90A and 25/50 flame spread/smoke developed ratings when tested in accordance with CAN/ULC S102;
 - .2 internally lined with 25 mm (1") thick aluminium foil faced glass fibre lining material meeting NFPA 90A and 25/50 flame spread/smoke developed ratings when tested in accordance with CAN/ULC S102; this applies to all exhaust VAV terminals serving showers
 - .3 exposed cut edges of the liner material factory coated with NFPA 90A and CAN/ULC S102 approved sealant;
 - .4 50 mm (2") long, round inlet duct connection;
 - .5 rectangular discharge opening with slip and drive cleat duct connection facilities;
 - .6 protective galvanized steel shroud for controller and damper actuator.
 - .2 air valve damper, normally open, galvanized steel blade with peripheral gasket, pivoting in self-lubricating bearings and with air leakage past a closed damper of 2% or less of rated capacity at 750 Pa (3" wc) inlet static pressure;
 - .3 air flow sensor located at box inlet, complete with gauge taps, multiple pressure sensing ports, and an averaging chamber designed to accurately average the flow across the inlet of box with an accuracy of within 5% with a 90° sheet metal elbow located directly at inlet, and amplify the sensed air flow signal;
 - .4 controller/actuator supplied as part of controls work specified in Section entitled Automatic Control Systems, shipped to box manufacturer's plant by controls supplier, and factory installed and connected by box manufacturer;
- .2 Terminal box to be complete with attenuator or lined discharge duct in place. Maximum sound power levels in decibels and specific static pressure are scheduled on drawings for each size of box.

SCHEDULE OF VARIABLE AIR VOLUME BOXES

UNIT DESIGNATION	AREA SERVED	MANUFACTURER	MODEL NO.	AIR FLOW RANGE (L/s)		MAX DISCHARGE N.C WITH ATTENUATOR	MX.RADIATED N.C	INLET DIAMETER (mm)	ATTENUATOR LENGTH (mm)	REMARKS
				MIN.	MAX					
5S	SEE FLOOR PLANS	EH PRICE	SDVQ	30	235	<30	<30	127	914	1,2,3,6,7
7S	SEE FLOOR PLANS	EH PRICE	SDVQ	45	380	<30	<30	178	914	1,2,3,6,7
9S	SEE FLOOR PLANS	EH PRICE	SDVQ	75	660	<30	<30	229	914	1,2,3,6,7
10S	SEE FLOOR PLANS	EH PRICE	SDVQ	100	850	<30	<30	254	914	1,2,3,6,7
12S	SEE FLOOR PLANS	EH PRICE	SDVQ	145	1230	<30	<30	305	914	1,2,3,6,7
5E	SEE FLOOR PLANS	EH PRICE	SDEQ	25	165	<30	<30	305x203	1359	1,2,3,4,5,7
9E	SEE FLOOR PLANS	EH PRICE	SDEQ	80	500	<30	<30	356x318	1359	1,2,3,4,5,7
10E	SEE FLOOR PLANS	EH PRICE	SDEQ	105	640	<30	<30	356x318	1359	1,2,3,4,5,7
12E	SEE FLOOR PLANS	EH PRICE	SDEQ	145	995	<30	<30	406x381	1359	1,2,3,4,5,7
14E	SEE FLOOR PLANS	EH PRICE	SDEQ	185	1230	<30	<30	508x445	1448	1,2,3,4,5,7

NOTES:
 1. ALL VAV BOXES SHALL BE COMPLETE WITH DEDICATED ROOM TEMPERATURE SENSOR AS SHOWN IN THE PLANS
 2. V.A.V. BOX SHALL BE PRESSURE INDEPENDENT, COMPLETE WITH CROSS FLOW SENSOR. V.A.V. BOXES SHALL BE CONTROLLED THROUGH THE DDC SYSTEM.
 3. DDC CONTROLLER/ACTUATOR AND POWER TRANSFORMER SHALL BE SUPPLIED BY CONTROLS MANUFACTURER AND INSTALLED BY V.A.V. BOX MANUFACTURER
 4. EXHAUST VAV'S SERVING SHOWER AREAS SHALL HAVE SOLID SHEET METAL LINER OVER INSULATION.
 5."E" EXHAUST AIR VAV BOX
 6."S" SUPPLY AIR VAV BOX
 7. FOR ACTUAL AIR FLOW SETTINGS REFER TO FLOOR PLAN.

Air Terminal Units



SINGLE DUCT TERMINAL UNIT
DIGITAL CONTROLS • PRESSURE INDEPENDENT
CONSTANT OR VARIABLE VOLUME
MODEL: D3001

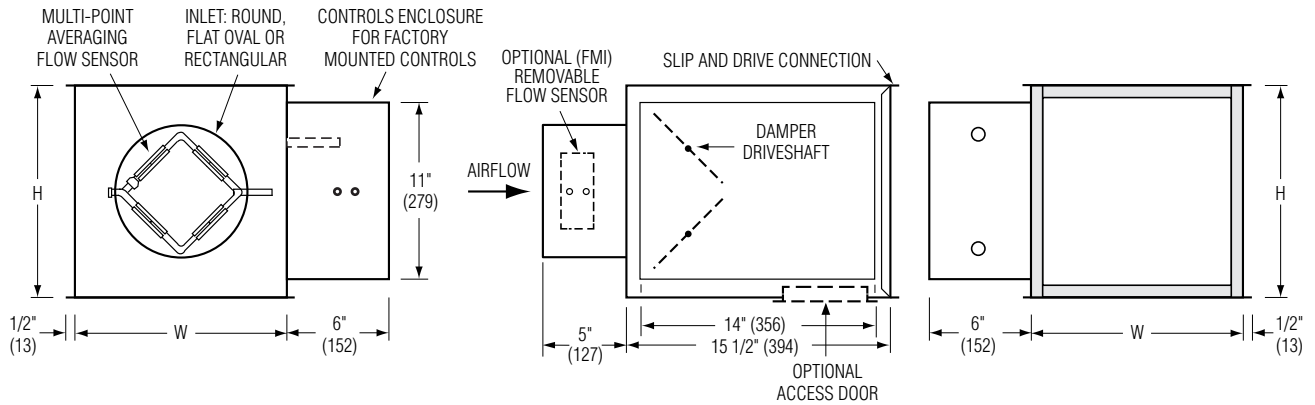

Dimensional Data

Unit Size	Airflow Range* cfm (l/s)	W	H	Inlet Size
4	0 – 225 (0 – 106)	10 (254)	10 (254)	3 7/8 (98) Round
5	0 – 400 (0 – 189)	10 (254)	10 (254)	4 7/8 (124) Round
6	0 – 550 (0 – 260)	10 (254)	10 (254)	5 7/8 (149) Round
7	0 – 800 (0 – 378)	12 (305)	12 1/2 (318)	6 7/8 (175) Round
8	0 – 1100 (0 – 519)	12 (305)	12 1/2 (318)	7 7/8 (200) Round
9	0 – 1400 (0 – 661)	14 (356)	12 1/2 (318)	8 7/8 (225) Round
10	0 – 1840 (0 – 868)	14 (356)	12 1/2 (318)	9 7/8 (251) Round
12	0 – 2500 (0 – 1180)	18 (457)	12 1/2 (318)	12 15/16 x 9 13/16 (329 x 249) Oval
14	0 – 3125 (0 – 1475)	24 (610)	12 1/2 (318)	16 1/16 x 9 13/16 (408 x 249) Oval
16	0 – 3725 (0 – 1758)	28 (711)	12 1/2 (318)	19 3/16 x 9 13/16 (487 x 249) Oval
24 x 16	0 – 8330 (0 – 3931)	38 (965)	18 (457)	23 7/8 x 15 7/8 (606 x 403) Rect.

* Maximum airflow limit is based upon 1.5" w.g. (373 Pa) max. differential pressure signal from Diamond Flow Sensor.

Standard Features:

- 22 ga. (0.86) galvanized steel casing, mechanically sealed, low leakage construction.
- 16 ga. (1.63) corrosion-resistant steel inclined opposed blade damper with extruded PVC seals (single blade on size 4, 5, 6). 45° rotation, CW to close. Tight close-off. Damper leakage is less than 2% of the terminal rated airflow at 3" w.g. (750 Pa).
- 1/2" (13) dia. plated steel drive shaft. An indicator mark on the end of the shaft shows damper position.
- Multi-point averaging Diamond Flow Sensor. Aluminum construction. Supplied with balancing tees.
- Rectangular discharge with slip and drive cleat duct connection.
- Full NEMA 1 type controls enclosure for factory mounted controls.

- 3/4" (19), dual density insulation, exposed edges coated to prevent air erosion. Meets the requirements of NFPA 90A and UL 181.
- Right-hand controls location is standard (shown) when looking in direction of airflow. Optional left hand controls mounting is available.
- Model D3001 can be installed horizontally, vertical or at any angle. Operation is not affected by position.

Digital Controls:

- Factory mounted (supplied by others)
 - Field mounted (supplied by others)
 - Nailor EZvav
- See separate submittal.

Options and Accessories:

- Fiber-free liner.
- Perforated metal liner.
- Solid metal liner.
- Steri-liner.
- Steri-liner + Perforated metal liner.
- 1" (25) liner.
- FMI Removable insert type Flow Sensor.
- Bottom access door.
- 24 VAC control transformer.
- 20 ga. (1.00) construction.
- Toggle disconnect switch.
- Controls enclosure for field mounted controls.
- Hanger brackets.
- Dust tight enclosure seal.
- Ultra low leakage casing.



Intertek



Project: Brampton Victoria Park Arena
Engineer: WSP MMM Group
Tag: VAV-S

Page 1 of 2.
 Dimensions are in inches (mm).

DATE	B SERIES	SUPERSEDES	DRAWING NO.
1 - 10 - 25	3000	11 - 29 - 22	D3001-1

AT3I 3' Integral Sound Attenuator

- Single continuous length terminal construction minimizes casing leakage.
- Continuous internal insulation reduces insulation seams and minimizes airflow disturbance.
- Supplied with same liner as basic unit.

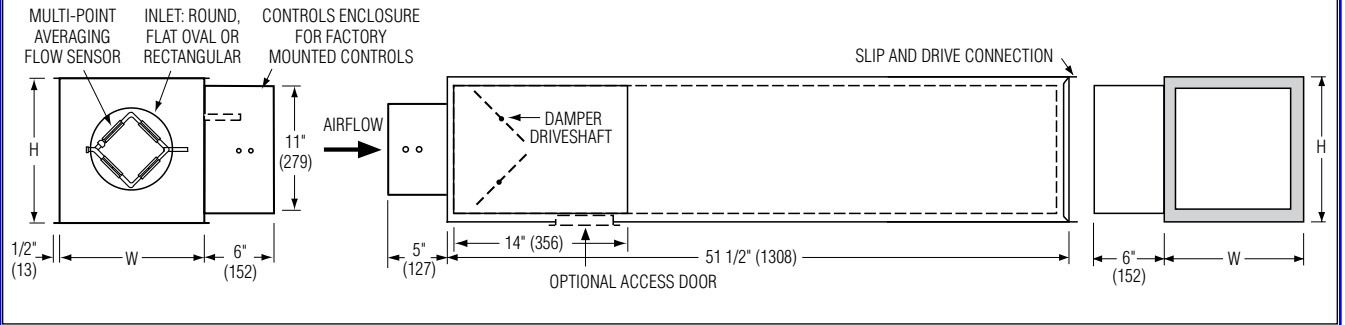

Dimensional Data

Unit Size	W	H	Access Door	FF Nominal Outlet Size
4, 5, 6	10 (254)	10 (254)	8 x 5 (203 x 127) Flat Oval	4, 5, 6 (102, 127, 152)
7, 8	12 (305)	12 1/2 (318)		7, 8 (178, 203)
9, 10	14 (356)	12 1/2 (318)		9, 10 (229, 254)
12	18 (457)	12 1/2 (318)		12 (305)
14	24 (610)	12 1/2 (318)	12 x 6 (305 x 152)	14 (356)
16	28 (711)	12 1/2 (318)		16 (406)
24 x 16	38 (965)	18 (457)	Flat Oval	-

Project: Brampton Victoria Park Arena
Engineer: WSP MMM Group
Tag: VAV-S

Page 2 of 2.
Dimensions are in inches (mm).

DATE	B SERIES	SUPERSEDES	DRAWING NO.
1 - 10 - 25	3000	11 - 29 - 22	D3001-1

Performance Data • Discharge Sound Power Levels

3000 Series • Basic Unit

Fiberglass Liner



Inlet Size	Airflow		Min. inlet ΔPs	Sound Power Octave Bands @ Inlet Pressure (ΔPs) shown																																									
				Minimum ΔPs							0.5" wg (125Pa) ΔPs							1.0" wg (250Pa) ΔPs							1.5" wg (375Pa) ΔPs							2.0" wg (500Pa) ΔPs							3.0" wg (750Pa) ΔPs						
				"w.g. Pa	2	3	4	5	6	7	2	3	4	5	6	7	2	3	4	5	6	7	2	3	4	5	6	7	2	3	4	5	6	7	2	3	4	5	6	7					
4	225	106	0.53	133	65	60	58	60	52	47	*	*	*	*	*	*	70	69	65	61	52	49	72	71	67	62	54	51	73	72	68	64	57	54	74	74	70	66	60	57					
	200	94	0.43	106	64	58	56	58	49	46	67	65	63	61	50	46	69	68	64	60	51	48	72	71	66	62	54	51	73	72	67	63	56	54	73	73	70	67	59	57					
	150	71	0.10	25	61	53	50	50	40	37	65	62	55	51	42	39	68	66	60	56	48	45	69	68	62	58	51	48	69	69	65	60	53	50	69	69	68	67	58	54					
	100	47	0.11	28	59	44	34	29	-	-	63	56	50	46	37	32	64	62	57	52	45	41	64	62	61	57	49	44	64	62	62	63	53	48	64	62	63	66	58	54					
	75	35	0.06	16	57	43	33	29	-	-	61	54	48	44	35	29	63	58	57	53	44	38	61	58	59	59	50	44	60	58	60	62	53	48	60	58	60	62	56	53					
5	400	189	0.19	48	62	57	56	61	53	48	67	64	65	64	54	49	71	68	70	67	56	51	73	70	72	69	58	53	75	72	73	70	59	55	76	74	75	71	62	58					
	300	142	0.11	28	61	54	51	55	46	41	67	64	62	60	49	44	70	69	65	63	52	48	73	70	67	64	54	51	74	72	69	66	56	53	75	74	71	68	59	57					
	250	118	0.05	12	59	50	47	49	40	34	65	63	57	55	44	40	69	67	61	58	48	45	71	70	63	61	51	48	72	71	65	63	54	51	73	72	68	66	58	55					
	200	94	0.05	13	58	46	42	42	32	26	65	61	53	50	40	36	68	64	57	55	45	42	69	67	60	58	49	46	70	68	63	60	52	50	71	69	66	65	56	54					
	125	59	0.02	5	57	42	31	27	-	-	63	52	47	44	34	30	64	58	54	50	41	38	65	60	59	55	46	42	65	60	61	62	50	46	65	60	63	67	59	53					
6	550	260	0.01	2	62	58	55	58	48	44	70	66	61	60	51	48	73	69	64	63	54	51	75	72	67	65	56	54	77	75	70	68	59	57	78	77	73	70	61	59					
	450	212	0.01	2	59	54	50	53	43	39	68	64	57	55	47	44	71	68	61	59	51	49	74	72	65	62	55	53	76	74	68	65	58	56	77	75	70	67	60	58					
	400	189	0.01	2	57	52	48	50	39	34	66	62	55	53	45	43	69	66	59	57	49	47	72	70	63	60	53	51	74	71	66	63	56	54	76	72	69	65	58	57					
	200	94	0.01	2	55	42	35	33	22	22	63	52	46	44	37	34	65	57	52	49	42	39	67	61	57	53	46	44	67	62	60	60	51	48	67	62	62	66	56	52					
	100	47	0.01	2	52	38	-	-	-	-	57	47	43	38	31	29	57	50	49	49	40	37	56	52	55	59	49	44	57	52	55	60	54	50	57	52	55	61	58	55					
7	800	378	0.01	2	67	62	61	61	53	48	71	66	65	63	55	50	74	69	67	65	57	54	77	72	70	68	60	57	79	75	73	70	62	59	81	78	76	73	65	62					
	650	307	0.01	2	63	58	55	56	47	42	69	64	60	58	51	47	72	68	64	62	55	51	76	72	68	65	58	55	78	76	71	67	61	58	80	76	73	70	63	61					
	550	260	0.01	2	59	54	51	51	42	36	66	61	57	55	49	46	70	65	61	59	52	49	74	70	65	62	55	53	76	71	68	65	59	56	78	73	71	67	61	59					
	335	158	0.01	2	57	47	42	40	31	28	64	56	52	50	44	40	68	60	56	54	48	44	71	64	61	58	51	48	71	66	64	62	55	52	72	67	67	67	59	56					
	225	106	0.01	2	52	40	39	35	26	21	60	50	48	44	37	34	61	54	53	51	44	40	63	58	58	58	51	46	63	58	60	60	55	51	64	59	61	62	58	55					
8	1100	519	0.01	2	71	67	66	65	57	53	73	69	68	66	58	53	76	72	71	68	61	56	78	74	73	70	63	59	81	77	76	73	66	62	84	80	79	76	69	65					
	900	425	0.01	2	67	63	60	59	51	46	71	66	64	62	55	51	74	70	67	65	58	54	77	73	71	68	61	58	80	76	74	70	64	61	82	78	76	73	67	63					
	700	330	0.01	2	62	58	54	52	44	38	67	63	59	57	52	49	71	67	63	61	55	52	76	71	67	65	58	55	78	74	70	67	62	58	79	77	73	70	65	62					
	600	283	0.01	2	59	54	50	48	40	33	65	61	57	55	51	47	70	66	61	59	54	50	75	70	65	63	57	53	76	73	68	65	60	56	77	75	71	67	63	59					
	400	189	0.01	2	52	43	39	35	26	21	62	55	52	50	43	39	66	61	57	54	48	44	69	66	61	58	53	49	70	67	64	61	56	52	70	68	68	64	59	56					
9	1400	661	0.01	2	71	65	67	65	59	54	75	69	70	68	60	55	78	72	72	71	62	57	80	74	75	73	64	60	82	77	77	75	67	63	84	79	79	77	70	66					
	1250	590	0.01	2	67	62	62	61	54	49	73	67	66	64	57	53	75	70	69	67	60	56	78	73	73	70	63	59	80	75	75	72	65	62	83	77	76	74	68	64					
	900	425	0.01	2	62	57	54	51	44	37	68	62	60	58	53	49	71	66	63	62	55	52	75	69	67	65	58	55	77	72	70	67	61	58	79	75	73	70	65	62					
	675	319	0.01	2	57	51	48	44	37	30	64	59	56	54	49	44	69	64	60	58	53	48	73	68	64	62	56	52	75	70	67	64	59	56	76	72	70	67	62	59					
	450	212	0.01	2	53	41	37	33	24	-	62	53	51	49	42	38	65	59	56	53	47	44	68	64	60	58	52	49	69	65	63	60	56	53	70	66	67	63	59	56					
10	1850	873	0.01	2	71	66	67	66	60	55	78	72	71	71	62	57	80	74	73	73	64	59	81	76	76	75	66	61	82	78	77	77	68	64	83	79	79	77	71	66					
	1650	779	0.01	2	68	63	64	63	56	51	75	69	68	67	59	54	77	72	71	70	62	57	79	75	74	72	64	60	81	77	75	74	66	63	83	79	77	76	69	65					
	1100	519	0.01	2	63	58	54	50	43	36	68	64	61	59	53	49	71	67	64	62	56	52	74	69	66	65	58	55	76	72	69	67	61	59	78	75	72	70	64	62					
	825	389	0.01	2	55	49	45	41	34	26	63	58	55	53	47	42	68	63	59	57	51	47	72	67	63	61	55	52	74	70	66	64	59	56	75	72	69	67	62	59					
	550	260	0.01	2	53	42	36	30	21	-	61	53	50	48	41	37	64	58	55	53	47	43	67	63	59	57	52	49	69	65	62	60	56	53	70	67	66	63	59	56					
12	2500	1180	0.01	2	67	61	66	65	60	54	78	70	71	70	63	57	80	73	73	73	65	60	81	75	76	75	67	62	83	77	78	77	70	66	85	79	79	79	73	69					
	2000	944	0.01	2	63	57	60	60	55	48	75	67	66	66	59	53	77	70	69	69	62	57	78	72	73	71	65	60	80	75	74	73	68	63	82	77	76	76	70	67					
	1600	755	0.01	2	59	51	54	53	47	40	71	64	62	61	55	50	74	67	66	65	58	54	76	70	69	68	62	58	78	73	71	70	65	61	79	75	73	72	67	65					
	1200	566	0.01	2	55	46	47	45	39	32	67	60	58	57	51	45	70	64	62	61	55	51	73	67	65	64	59	56	75	70	68	66	62	59	76	73	71	69	65	62					
	800	378	0.01	2	52	40	35	31	24	22	62	52	51	50	45	41	65	57	56	54	50	46	68	62	60	59	55	52	69	64	64	62	58	56	71	66	67	65	61	59					
14	3125	1475	0.01	2	71	64																																							

Performance Data • Radiated Sound Power Levels

3000 Series • Basic Unit

Fiberglass Liner



Inlet Size	Airflow		Min. inlet ΔPs		Sound Power Octave Bands @ Inlet Pressure (ΔPs) shown																																									
					Minimum ΔPs							0.5" wg (125Pa) ΔPs							1.0" wg (250Pa) ΔPs							1.5" wg (375Pa) ΔPs							2.0" wg (500Pa) ΔPs							3.0" wg (750Pa) ΔPs						
					2	3	4	5	6	7	2	3	4	5	6	7	2	3	4	5	6	7	2	3	4	5	6	7	2	3	4	5	6	7	2	3	4	5	6	7						
4	225	106	0.53	133	-	37	33	33	-	-	*	*	*	*	*	*	51	48	45	38	32	30	55	54	49	42	33	32	55	55	51	44	35	33	56	57	54	48	39	38						
	200	94	0.43	106	-	36	33	32	-	-	-	39	37	38	29	29	49	46	43	37	30	29	53	52	47	40	32	31	53	53	50	42	33	33	54	55	53	47	37	37						
	150	71	0.10	25	-	35	29	31	-	-	-	40	36	30	25	23	47	46	40	34	28	26	49	50	47	39	31	30	47	48	48	43	34	32	48	48	48	50	40	37						
	100	47	0.11	28	-	-	-	-	-	-	-	37	32	27	-	-	-	43	42	34	27	23	-	44	45	41	32	29	-	43	46	46	36	32	-	42	44	51	43	38						
	75	35	0.06	16	-	-	-	-	-	-	-	37	31	26	-	-	-	41	43	37	29	24	-	42	45	42	32	29	-	38	42	45	40	33	-	36	41	48	44	40						
5	400	189	0.19	48	49	41	34	36	34	27	52	45	40	40	39	36	56	48	45	38	37	34	60	52	49	40	39	34	63	56	51	42	40	36	63	59	56	45	44	40						
	300	142	0.11	28	47	38	32	32	30	27	50	43	37	35	33	31	54	46	44	37	35	31	57	49	47	39	38	33	59	52	49	40	39	35	59	55	53	43	43	39						
	250	118	0.05	12	-	35	31	25	23	-	50	40	36	32	30	25	54	45	42	33	32	28	55	48	45	35	35	30	56	51	48	37	37	32	57	53	51	42	41	35						
	200	94	0.05	13	-	-	-	-	-	-	50	38	34	27	25	-	52	43	39	31	30	25	52	45	43	32	32	28	53	48	46	36	36	30	53	48	48	44	41	34						
	125	59	0.02	5	-	-	-	-	-	-	-	33	29	21	-	-	48	40	38	28	27	-	48	42	42	34	33	27	49	42	44	39	38	29	49	42	44	47	46	37						
6	550	260	0.01	2	48	47	41	39	31	29	49	48	42	41	35	31	57	52	46	41	35	32	62	55	49	45	36	34	64	58	51	45	40	38	67	61	56	48	44	43						
	450	212	0.01	2	48	44	37	35	30	28	48	47	40	38	32	29	56	50	45	40	34	31	59	53	48	44	36	33	61	55	50	43	39	37	64	58	54	46	42	41						
	400	189	0.01	2	-	42	33	33	28	26	49	46	39	35	30	28	56	49	44	38	32	29	59	52	47	40	36	33	62	54	49	42	39	36	64	58	54	45	42	41						
	200	94	0.01	2	-	-	-	-	-	-	47	36	30	24	-	-	53	43	38	30	29	28	53	45	43	32	31	30	53	47	44	36	32	32	55	49	46	43	37	37						
	100	47	0.01	2	-	-	-	-	-	-	-	34	27	-	-	-	-	35	38	33	29	24	45	39	40	37	31	28	47	39	40	42	37	32	46	40	40	46	44	38						
7	800	378	0.01	2	50	47	51	37	36	36	50	48	45	37	33	33	57	52	48	40	34	32	63	58	53	46	38	35	68	62	56	49	40	38	70	66	61	54	45	42						
	650	307	0.01	2	49	45	46	38	31	30	49	48	45	37	31	29	54	50	47	40	34	32	60	54	50	44	37	35	64	58	54	48	40	38	67	63	58	51	44	43						
	550	260	0.01	2	48	43	41	33	27	25	48	44	40	32	28	26	55	49	45	38	32	30	61	54	49	43	36	33	64	58	52	45	38	36	65	61	57	50	42	40						
	335	158	0.01	2	-	-	28	33	-	-	-	40	35	29	24	-	52	48	42	36	30	28	57	51	46	40	32	30	57	52	48	42	34	32	57	53	50	47	39	38						
	225	106	0.01	2	-	-	-	-	-	-	-	39	33	28	-	-	50	45	40	34	28	25	52	47	43	38	31	29	51	47	43	41	33	31	52	48	45	42	35	36						
8	1100	519	0.01	2	52	50	45	37	34	33	57	51	46	37	35	32	60	54	51	40	38	33	65	57	53	43	42	36	67	60	56	45	44	39	70	63	60	49	48	42						
	900	425	0.01	2	51	47	40	34	31	29	56	50	45	37	34	31	58	53	49	39	37	33	63	56	51	42	42	36	65	58	54	44	44	39	68	60	56	47	48	42						
	700	330	0.01	2	50	43	37	31	29	25	51	47	42	33	31	28	57	51	47	37	36	32	61	53	50	40	39	35	63	55	51	42	41	37	64	59	56	45	44	40						
	600	283	0.01	2	-	39	33	29	26	-	50	45	40	31	30	26	57	49	45	35	34	31	60	53	49	38	38	33	61	55	51	40	40	36	63	59	56	44	43	40						
	400	189	0.01	2	-	35	26	-	-	-	49	41	36	28	27	24	54	47	41	32	31	30	57	52	46	35	34	32	57	52	47	37	36	34	59	54	51	41	40	39						
9	1400	661	0.01	2	51	46	46	44	37	35	52	47	46	41	38	35	57	53	49	42	37	35	64	58	53	47	41	37	66	63	57	50	43	40	69	67	61	54	47	44						
	1250	590	0.01	2	51	46	45	42	35	35	51	46	46	41	37	34	56	52	48	42	36	34	63	57	52	46	40	37	65	62	56	50	43	40	68	65	60	53	46	44						
	900	425	0.01	2	48	40	39	36	30	29	50	45	42	37	32	30	56	50	45	40	35	33	60	54	49	44	39	36	63	58	52	47	41	38	64	61	56	50	44	42						
	675	319	0.01	2	47	37	31	29	22	-	49	41	36	31	28	25	55	48	42	37	32	30	58	52	46	41	35	33	60	56	50	44	38	36	60	57	52	47	41	39						
	450	212	0.01	2	-	-	24	-	-	-	48	40	33	30	26	24	53	46	39	34	30	29	54	49	43	38	33	31	55	50	46	41	35	34	56	52	48	45	39	38						
10	1850	873	0.01	2	57	47	48	40	36	27	58	49	48	40	37	31	60	55	52	45	39	35	64	59	56	50	43	39	65	62	57	52	46	42	68	66	61	56	49	46						
	1650	779	0.01	2	55	45	45	40	35	26	57	49	46	39	36	30	59	54	51	44	38	34	63	58	55	49	42	38	64	60	56	51	45	41	67	65	60	55	48	45						
	1100	519	0.01	2	51	37	35	30	25	-	53	46	42	35	31	27	55	50	47	41	35	31	60	54	50	45	39	36	61	56	51	47	42	39	64	61	55	51	45	43						
	825	389	0.01	2	-	33	29	25	-	-	50	43	38	32	29	25	55	48	43	38	33	30	58	52	47	42	37	34	59	54	49	44	39	37	61	57	53	49	43	41						
	550	260	0.01	2	-	-	-	-	-	-	-	38	33	29	25	-	51	44	38	34	30	28	53	47	42	38	34	32	56	50	45	41	36	35	57	52	48	45	40	38						
12	2500	1180	0.01	2	57	55	54	50	42	36	60	57	53	46	41	38	63	61	54	50	42	39	66	63	57	53	45	41	67	64	59	55	48	44	70	69	63	59	52	50						
	2000	944	0.01	2	54	50	48	44	37	33	58	55	51	46	39	35	61	59	53	49	42	37	64	61	56	52	45	41	65	62	58	55	48	44	68	66	61	58	51	49						
	1600	755	0.01	2	52	45	41	36	30	27	56	52	45	40	34	30	59	56	49	46	38	35	61	58	53	49	42	39	62	60	55	51	44	42	65	64	58	55	48	46						
	1200	566	0.01	2	47	39	33	29	24	-	52	48	40	36	30	27	55	52	45	41	34	32	58	55	49	45	38	36	60	58	51	48	41	39	61	61	55	52	45	44						
	800	378	0.01	2	-	-	-	-	-	-	50	41	34	30	26	-	52	48	41	37	31	30	5																							



**SINGLE DUCT EXHAUST TERMINAL UNIT WITH
OPTIONAL SOUND ATTENUATOR
DIGITAL CONTROLS
VARIABLE OR CONSTANT VOLUME
MODEL: D30X**

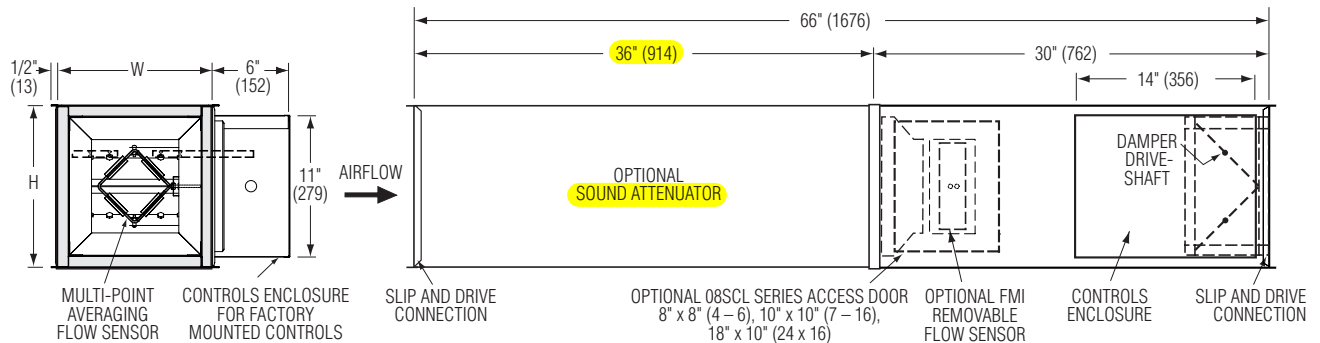

Dimensional Data

Unit Size	Min.- Max. Airflow Range* cfm (l/s)	W	H
4	30 – 210 (14 – 99)	10 (254)	10 (254)
5	50 – 345 (24 – 163)	10 (254)	10 (254)
6	80 – 580 (38 – 274)	10 (254)	10 (254)
7	95 – 680 (45 – 321)	12 (305)	12 1/2 (318)
8	140 – 970 (66 – 458)	12 (305)	12 1/2 (318)
9	170 – 1210 (80 – 571)	14 (356)	12 1/2 (318)
10	220 – 1540 (104 – 727)	14 (356)	12 1/2 (318)
12	320 – 2270 (151 – 1071)	18 (457)	12 1/2 (318)
14	360 – 2520 (170 – 1189)	24 (610)	12 1/2 (318)
16	505 – 3580 (238 – 1689)	28 (711)	12 1/2 (318)
24 x 16	990 – 7000 (467 – 3303)	38 (965)	18 (457)

* Minimum flows are based upon 0.02" w.g. (5 Pa) differential pressure from flow sensor. The maximum flow rate represents the diamond flow sensor's differential pressure reading at 1" w.g. (250 Pa).



Standard Features:

- Venturi valve inlet for reduced pressure drop.
- 22 ga. (0.86) zinc coated steel casing, mechanically sealed, low leakage construction.
- 16 ga. (1.63) corrosion-resistant steel inclined opposed blade damper with extruded PVC seals. 45° rotation, CW to close. Tight close-off. Damper leakage is less than 2% of the terminal rated airflow at 3" w.g. (750 Pa).
- 1/2" (13) dia. plated steel drive shaft. An indicator mark on the end of the shaft shows damper position.
- Multi-point averaging Diamond Flow Sensor. Aluminum construction. Supplied with balancing tees.
- Rectangular inlet and discharge with slip and drive cleat duct connection.
- Full NEMA 1 type controls enclosure for factory mounted controls.

- 3/4" (19) dual density insulation, exposed edges coated to prevent air erosion. Meets the requirements of NFPA 90A and UL 181.
- Right-hand controls location is standard (shown) when looking in direction of airflow. Optional left hand controls mounting is available.

Optional Sound Attenuator Section:

- Mounted on VAV section inlet for quiet operation.
- Same liner as terminal unit.

Digital Controls (by others):

- Factory mount. (See separate submittal)
- Field mount.

Options and Accessories:

- Bottom Mount Control Enclosure (See page 2)
- Side access door.
- FMI Removable insert type Diamond Flow Sensor.
- Steri-Liner.
- Fiber-Free liner.
- Solid metal liner. [shower area only](#)
- Perforated metal liner.
- Steri-liner + Perforated metal liner.
- Factory wrapped inlets and outlets.
- 24 VAC control transformer.
- Toggle disconnect switch.
- Hanger brackets.
- Controls enclosure for field mounted controls.
- Dust tight enclosure seal.

Project: Brampton Victoria Park Arena
Engineer: WSP MMM Group
Tag: VAV-E

Dimensions are in inches (mm).

DATE	B SERIES	SUPERSEDES	DRAWING NO.
3 - 12 - 18	3000	4 - 10 - 16	D30X

Performance Data • Radiated Sound Power Levels
30X Series • Optional Attenuator
Fiberglass Liner

Inlet Size	Airflow		Min. inlet ΔPs		Sound Power Octave Bands @ Inlet Pressure (ΔPs) shown																																									
					Minimum ΔPs							0.5" w.g. (125Pa) ΔPs							1.0" w.g. (250Pa) ΔPs							1.5" w.g. (375Pa) ΔPs							2.0" w.g. (500Pa) ΔPs							3.0" w.g. (750Pa) ΔPs						
					2	3	4	5	6	7	2	3	4	5	6	7	2	3	4	5	6	7	2	3	4	5	6	7	2	3	4	5	6	7	2	3	4	5	6	7						
4	200	94	0.63	159	52	42	33	27	27	21	*	*	*	*	*	*	55	43	34	28	27	22	59	49	39	33	28	23	59	50	41	36	29	25	58	50	44	39	32	28						
	150	71	0.37	92	48	35	27	-	-	-	49	36	27	-	-	-	54	43	33	27	21	-	54	45	37	31	23	-	54	45	39	33	26	22	52	44	40	26	29	26						
	100	47	0.17	43	-	-	-	-	-	-	47	35	24	-	-	-	47	38	30	24	-	-	49	39	33	28	-	-	49	38	33	29	23	21	48	38	34	32	29	26						
	50	24	0.05	12	-	-	-	-	-	-	-	-	-	-	-	-	-	-	-	-	-	-	-	-	24	23	-	-	-	31	26	25	23	-	-	47	36	31	30	28	25					
	30	14	0.02	5	-	-	-	-	-	-	-	-	-	-	-	-	-	-	-	-	-	-	-	-	24	23	-	-	-	32	26	25	24	-	-	35	31	30	28	26						
5	300	142	0.55	136	51	42	35	27	25	-	*	*	*	*	*	*	55	45	37	31	26	21	60	50	40	35	29	23	62	53	42	37	32	26	62	53	47	41	37	31						
	250	118	0.35	87	-	39	31	23	-	-	-	39	32	23	-	-	55	44	35	30	22	-	58	49	39	34	27	21	59	50	42	36	30	24	59	51	45	40	35	30						
	200	94	0.23	57	-	-	-	-	-	-	-	37	29	21	-	-	53	44	34	29	-	-	55	46	38	33	25	-	54	47	40	35	29	24	53	47	42	38	33	29						
	125	59	0.10	25	-	-	-	-	-	-	-	-	-	-	-	-	-	39	33	27	-	-	-	40	35	30	23	-	-	39	36	31	27	23	-	40	36	34	32	29	29					
	100	47	0.06	15	-	-	-	-	-	-	-	-	-	-	-	-	-	-	36	30	24	-	-	-	36	32	27	23	-	-	35	32	29	27	23	-	37	33	32	32	28	28				
6	450	212	0.38	94	53	43	35	28	25	-	54	44	35	28	25	-	61	49	39	31	28	22	64	54	42	35	30	24	65	57	46	38	33	27	65	58	51	42	37	31						
	400	189	0.30	75	51	40	33	24	-	-	54	42	33	26	21	-	60	47	36	30	24	-	62	52	41	34	28	22	63	55	44	36	31	25	63	57	49	41	35	30						
	300	142	0.18	44	-	34	25	-	-	-	51	38	29	22	-	-	56	46	35	28	21	-	59	50	40	33	26	-	58	51	42	35	29	22	58	51	46	40	34	28						
	200	94	0.08	21	-	-	-	-	-	-	-	49	36	27	21	-	-	52	44	34	27	-	-	53	46	39	31	24	-	51	47	40	33	27	22	50	46	42	37	31	26					
	100	47	0.02	6	-	-	-	-	-	-	-	-	34	23	-	-	-	-	28	23	-	-	-	-	36	30	26	21	-	-	34	32	28	24	21	-	37	33	31	28	26	26				
7	650	307	0.50	125	56	50	42	33	27	25	56	50	42	33	27	25	59	52	42	35	30	27	64	54	46	41	34	29	67	56	47	44	36	31	69	59	50	47	39	34						
	550	259	0.35	88	53	46	38	28	24	-	54	43	34	26	25	-	59	49	41	35	29	23	64	52	44	40	32	27	66	54	45	42	34	29	67	57	48	45	37	32						
	335	158	0.13	34	-	-	-	-	-	-	-	37	31	26	-	-	55	44	35	31	22	-	58	48	38	34	27	21	58	49	40	35	29	25	58	50	43	38	33	30						
	225	106	0.06	16	-	-	-	-	-	-	-	-	26	21	-	-	51	41	32	26	-	-	51	44	36	30	25	21	52	43	37	32	28	25	50	43	39	36	32	31						
	110	52	0.02	4	-	-	-	-	-	-	-	-	-	-	-	-	-	-	25	23	-	-	-	-	28	27	25	22	-	-	30	28	28	25	-	39	34	33	31	30	30					
8	800	377	0.35	87	57	47	41	32	26	20	59	48	40	31	26	21	63	53	45	37	31	27	66	55	45	38	33	29	68	57	47	39	35	31	70	60	50	42	38	36						
	700	330	0.27	68	53	44	38	29	22	-	57	46	37	28	23	-	62	50	41	34	29	25	65	53	43	36	32	27	67	56	45	38	33	29	68	58	49	41	37	34						
	600	283	0.20	51	50	40	34	26	-	-	54	43	35	27	-	-	61	48	39	32	26	21	64	52	42	35	30	26	65	55	44	37	32	28	65	57	48	40	36	33						
	400	189	0.09	24	51	38	30	22	-	-	50	38	31	25	-	-	56	45	36	30	22	-	58	49	39	33	27	22	58	50	42	35	30	25	58	51	44	38	34	31						
	175	83	0.02	5	-	-	-	-	-	-	-	50	40	30	25	-	-	-	36	31	27	23	-	-	37	33	30	26	23	-	38	34	31	30	27	49	42	36	34	33	31					
9	1050	495	0.39	98	59	50	44	34	30	28	59	49	43	34	31	28	63	53	45	36	32	28	66	56	49	41	36	32	68	58	52	44	36	32	70	61	56	48	40	35						
	900	425	0.29	73	54	46	40	30	25	21	57	47	39	31	26	21	61	51	44	35	29	-	64	54	48	40	32	26	66	56	51	43	35	29	68	60	54	47	40	34						
	675	318	0.16	40	-	40	33	23	-	-	54	44	36	28	21	-	58	49	42	34	26	-	61	52	47	39	31	24	63	54	49	42	34	28	64	56	52	45	37	32						
	450	212	0.07	17	-	-	-	-	-	-	52	39	33	26	-	-	54	45	41	33	24	-	56	48	43	36	28	22	57	50	44	38	30	25	57	51	46	41	34	30						
	225	106	0.02	4	-	-	-	-	-	-	-	-	-	-	-	-	50	38	31	27	-	-	51	39	34	31	25	21	50	40	36	33	28	24	50	42	39	36	31	29						
10	1350	637	0.44	110	56	48	40	34	32	25	56	49	40	33	32	25	63	53	43	37	34	27	67	56	46	39	35	30	70	59	48	41	37	31	73	63	53	45	40	35						
	1100	519	0.29	73	52	43	34	28	23	-	56	46	37	31	35	-	63	50	40	34	29	22	66	55	44	37	32	26	68	57	47	39	35	29	71	61	51	44	39	34						
	825	389	0.16	40	-	39	29	-	-	-	53	42	33	27	-	-	59	48	38	32	25	-	63	53	43	36	30	24	64	55	45	38	33	27	65	58	49	41	36	32						
	550	259	0.07	17	-	-	-	-	-	-	50	39	30	23	-	-	56	46	37	30	23	-	57	49	40	32	27	23	58	51	42	34	29	25	60	55	47	40	35	32						
	275	130	0.02	4	-	-	-	-	-	-	-	-	-	-	-	-	-	39	30	23	-	-	-	54	42	33	27	23	54	42	33	27	23	23	49	43	35	30	26	25						
12	2000	943	0.41	103	60	50	44	35	34	29	60	49	44	35	34	29	69	58	50	41	38	34	69	59	52	45	43	40	71	60	51	43	39	36	74	64	55	47	43	40						
	1600	755	0.27	68	54	47	42	37	39	33	57	50	45	41	46	40	64	53	46	41	43	38	67	57	48	41	40	35	69	59	50	42	38	35	70	62	53	45	42	39						
	1200	566	0.15	38	48	37	31	21	-	-	55	45	36	29	27	24	61	50	42	34	30	27	63	54	45	37	33	31	64	56	47	39	35	33	66	59	51	43	40	38						
	800	377	0.07	17	-	-	-	-	-	-	51	41	32	24	-	-	56	47	38	30	25	22	58	50	42	34	31	29	58	52	44	36	33	32	60	54	47	40	38	38						
	400	189	0.02	4	-	-	-	-	-	-	-	35	26	-	-	-	49	39	32	27	26	25	52	41	35	31	32	31	50	42	35	33	34	32	52	44	38	36	38	39						
14	2700	1274	0.58	145	65	57	53	42	35	31	*	*	*	*	*	*	67	58	50	41	38	34	69	60	51	43	37	34	71	62	52	44	39	35	73	65	55	48	42	38						
	2100	991	0.34	85	59	50	46	35	29	22	59	50	46	35	29	22	64	54	44	36	43	38	67	57	48	40	34	29	68	58	49	42	36	31	70	62	53	46	42	37						
	1550																																													

Performance Data • NC Level Application Guide

30X Series • Optional Attenuator

Fiberglass Liner

Inlet Size	Airflow cfm /s		Min. inlet ΔPs "w.g. Pa	NC Levels @ Inlet Pressure (ΔPs) shown													
				DISCHARGE w/36" (914) attenuator						RADIATED w/36" (914) attenuator							
				Min. ΔPs	0.5" w.g. (125 Pa)	1.0" w.g. (250 Pa)	1.5" w.g. (375 Pa)	2.0" w.g. (500 Pa)	3.0" w.g. (750 Pa)	Min. ΔPs	0.5" w.g. (125 Pa)	1.0" w.g. (250 Pa)	1.5" w.g. (375 Pa)	2.0" w.g. (500 Pa)	3.0" w.g. (750 Pa)		
4	200	94	0.63	159	-	*	-	-	-	-	-	-	*	-	21	21	20
	150	71	0.37	92	-	-	-	-	-	-	-	-	-	-	-	-	-
	100	47	0.17	43	-	-	-	-	-	-	-	-	-	-	-	-	-
	50	24	0.05	12	-	-	-	-	-	-	-	-	-	-	-	-	-
	30	14	0.02	5	-	-	-	-	-	-	-	-	-	-	-	-	-
5	300	142	0.55	136	-	*	-	-	-	-	-	-	*	-	23	25	25
	250	118	0.35	87	-	-	-	-	-	-	-	-	-	-	20	21	21
	200	94	0.23	57	-	-	-	-	-	-	-	-	-	-	-	-	-
	125	59	0.10	25	-	-	-	-	-	-	-	-	-	-	-	-	-
	100	47	0.06	15	-	-	-	-	-	-	-	-	-	-	-	-	-
6	450	212	0.38	94	-	-	-	-	20	21	-	-	24	28	29	29	29
	400	189	0.30	75	-	-	-	-	-	20	-	-	23	25	26	26	26
	300	142	0.18	44	-	-	-	-	-	-	-	-	-	21	20	20	20
	200	94	0.08	21	-	-	-	-	-	-	-	-	-	-	-	-	-
	100	47	0.02	6	-	-	-	-	-	-	-	-	-	-	-	-	-
7	650	307	0.50	125	-	-	-	-	23	25	-	-	21	28	31	34	34
	550	259	0.35	88	-	-	-	-	20	23	-	-	21	28	30	31	31
	335	158	0.13	34	-	-	-	-	-	-	-	-	-	20	20	20	20
	225	106	0.06	16	-	-	-	-	-	-	-	-	-	-	-	-	-
	110	52	0.02	4	-	-	-	-	-	-	-	-	-	-	-	-	-
8	800	377	0.35	87	-	-	-	20	23	25	-	21	26	30	33	35	35
	700	330	0.27	68	-	-	-	-	20	23	-	-	25	29	31	33	33
	600	283	0.20	51	-	-	-	-	20	21	-	-	24	28	29	29	29
	400	189	0.09	24	-	-	-	-	-	-	-	-	-	20	20	20	20
	175	83	0.02	5	-	-	-	-	-	-	-	-	-	-	-	-	-
9	1050	495	0.39	98	-	-	-	-	21	25	21	21	26	30	33	35	35
	900	425	0.29	73	-	-	-	-	20	24	-	-	24	28	30	33	33
	675	318	0.16	40	-	-	-	-	-	20	-	-	20	24	26	28	28
	450	212	0.07	17	-	-	-	-	-	-	-	-	-	-	-	20	20
	225	106	0.02	4	-	-	-	-	-	-	-	-	-	-	-	-	-
10	1350	637	0.44	110	-	-	-	23	25	29	-	-	26	31	35	39	39
	1100	519	0.29	73	-	-	-	20	23	25	-	-	26	30	33	36	36
	825	389	0.16	40	-	-	-	-	-	20	-	-	21	26	28	29	29
	550	259	0.07	17	-	-	-	-	-	-	-	-	-	-	20	24	24
	275	130	0.02	4	-	-	-	-	-	-	-	-	-	-	-	-	-
12	2000	943	0.41	103	-	-	-	24	26	30	23	23	34	34	36	40	40
	1600	755	0.27	68	-	-	-	20	23	28	-	-	28	31	34	35	35
	1200	566	0.15	38	-	-	-	-	20	28	-	-	24	26	28	30	30
	800	377	0.07	17	-	-	-	-	-	-	-	-	-	20	20	23	23
	400	189	0.02	4	-	-	-	-	-	-	-	-	-	-	-	-	-
14	2700	1274	0.58	145	-	*	23	28	29	33	29	*	31	34	36	39	39
	2100	991	0.34	85	-	-	21	25	25	28	21	21	28	31	33	35	35
	1550	731	0.18	46	-	-	-	-	-	21	-	-	23	25	25	28	28
	1050	495	0.09	22	-	-	-	-	-	-	-	-	-	-	20	21	21
	525	248	0.02	6	-	-	-	-	-	-	-	-	-	-	-	-	-
16	3500	1651	0.48	119	-	-	23	26	29	33	30	30	31	35	38	41	41
	2800	1321	0.31	77	-	-	20	24	26	30	21	23	29	33	34	36	36
	2100	991	0.18	44	-	-	-	21	21	25	-	-	23	26	29	31	31
	1400	660	0.08	20	-	-	-	-	-	-	-	-	-	20	21	23	23
	700	330	0.02	5	-	-	-	-	-	-	-	-	-	-	-	-	-
24 x 16	5350	2524	0.47	118	26	26	29	34	35	40	40	40	36	38	40	43	43
	5000	2358	0.40	100	25	25	28	33	34	39	39	39	35	36	39	41	41
16	4000	1887	0.26	65	-	20	25	30	34	36	30	30	31	34	35	36	36
	3000	1415	0.15	38	-	-	23	29	30	33	20	21	25	30	31	33	33
16	2000	943	0.07	18	-	-	21	24	26	29	-	-	21	24	26	29	29

Performance Notes:

1. NC Levels are calculated based on procedures as outlined on page A75.
2. Dash (-) in space indicates a NC less than 20.

3. Asterisk (*) in space indicates that the minimum inlet static pressure requirement is greater than 0.5" w.g. (125 Pa) at rated airflow.

Installation
Operation
Maintenance

Safety Consideration

The equipment covered by this manual is designed for safe and reliable operation within its design specification limits. To avoid personal injury or damage to equipment or property while installing or operating this equipment, it is essential that qualified, experienced personnel perform these functions using good judgment and safe practices. Equipment is not to be used by persons (including children) with reduced physical, sensory, or mental capabilities, or lack of experience and knowledge, unless they have been given supervision or instruction. Children being supervised should NOT play with equipment. Equipment's maximum altitude of use is 2,200 m.



CAUTION: DO NOT exceed coil's parameters. The coil's water temperature range is 40°F - 200°F. For standard coil wall thickness 0.016", the coil's maximum working pressure is 250 PSIG.

Receiving Inspection

After unpacking the assembly check it for shipping damage. If any shipping damage is found, report it immediately to the delivering carrier. During unpacking and installation do not handle by the inlet velocity sensor or the control package.

Determine Position of the Control Enclosure

The control enclosure can be installed on either side of the ductwork by flipping the VAV unit over 180 degrees. Unit with mercury contactors, pneumatic controls, and digital controls (DDC) need to be inspected before installing.



Important: Unit with mercury contactors is position sensitive. As a result, before installing unit with mercury contactors, inspect the position of the mercury contactors in the control enclosure. Mercury contactors must be heading up 90 degrees vertically. If they are heading down, unscrew the contactors, rotate 180 degrees, and reinstall them.

If unit is equipped with pneumatic controls, it should be mounted right side up and level within ± 10 degrees of horizontal, and parallel to the airflow. The first letter in the model number indicates control type (P is for pneumatic). If the unit is mounted upside down, the controller will have to be repositioned, re-piped, and recalibrated. Analog control units (A-analog model number pre-fix) may be installed in any

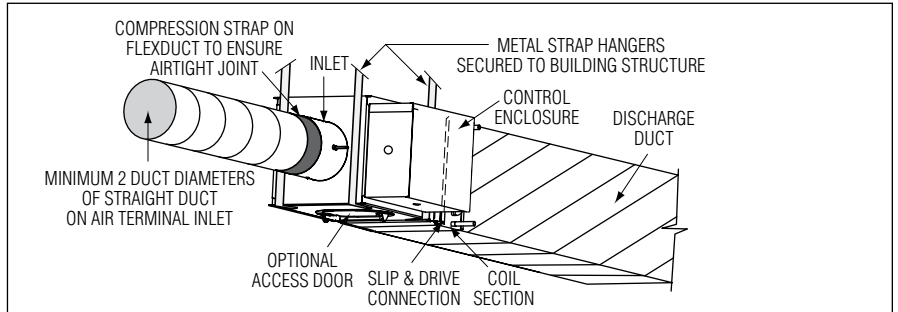

Figure 1: Support Using Hanger Straps (Shown: Model D30RW - Single Duct VAV Terminal Unit with Hot Water Heat).

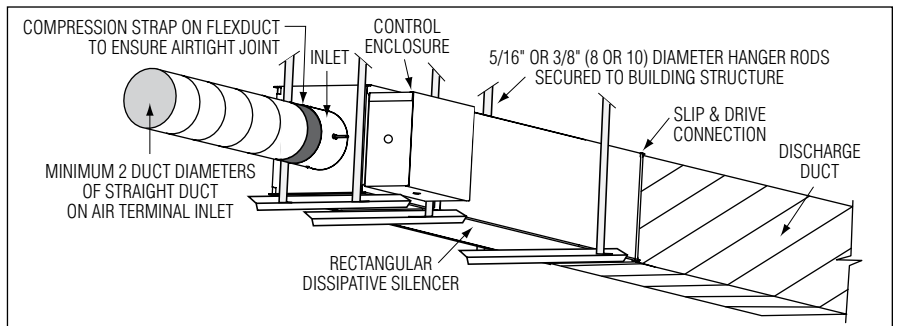

Figure 2: Support Using Unistrut and Rods (Shown: Model 3001Q - Single Duct Terminal Unit with Dissipative Silencer).

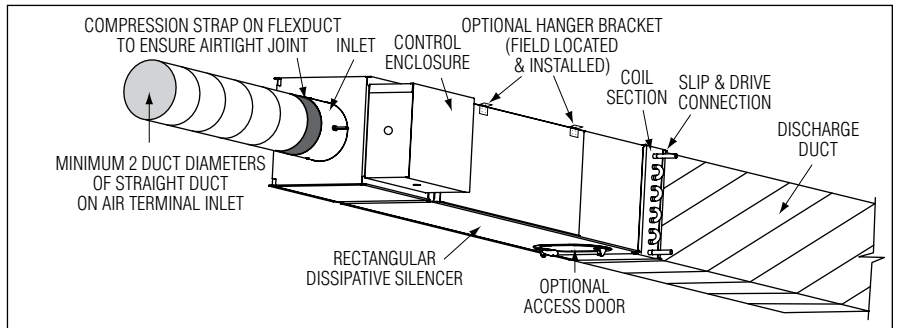

Figure 3: Support Using Optional Supplied Hanger Brackets (Shown: Model D30RWQ - Single Duct VAV Quiet Terminal Unit with Standard Dissipative Silencer and Hot Water Heat).

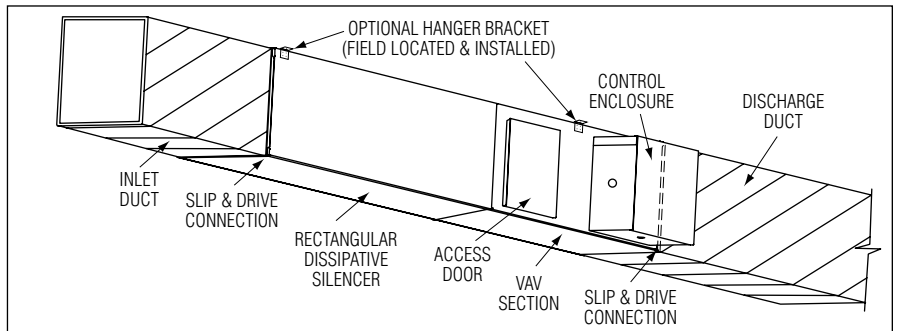

Figure 4: Support Using Optional Supplied Hanger Brackets (Shown: Model D30HQX - Single Duct VAV Exhaust Terminal Unit with Dissipative Silencer).

orientation. Some Digital (DDC) controls (D-digital model number pre-fix) are position sensitive dependent on the airflow sensor transducer. Check with the controls manufacturer for verification.

Supporting the Assembly

We recommend that each terminal unit be independently supported, especially when accessory modules, such as coils, attenuators, silencers or multiple outlets are present. Hanger straps may be used and screwed directly into the sides or bottom of the unit casing (see Fig. 1). Alternately, a carriage made of unistrut may be used, sometimes this is known as a trapeze setup. Support the VAV and any accessories separately (Fig. 2). When requested, unit is supplied with field mounted hanger brackets for use with hanger rod up to 3/8" (9.5) dia. Hanger brackets should be screwed into the top of the unit casing (see Fig. 3 & 4). Use the support method prescribed for the rectangular duct in the job specifications.

Duct Connections

Slip each inlet duct over the inlet collar of the terminal. Fasten and seal the connection as described in the job specification. The diameter of the inlet duct for round inlets (unit size 4 through 10) must be equal to the listed size of the terminal. The inlet collar of the terminal is made 1/8" (3) smaller than listed size in order to fit inside the duct (see figure 1). Unit size 12 through 16 utilize flat oval inlet collars and unit size 24 x 16 has a rectangular inlet collar. The flat oval inlets are undersized for flexible duct connection. For hard inlet duct connections, refer to submittal drawing for dimensional data. On exhaust units the duct should mate to the terminal using slip and drive connections (see Fig. 4).



Important: Do not insert ductwork inside the inlet collar of the assembly. For optimum performance, 2 to 3 equivalent diameters of straight duct should be installed prior to the inlet of the unit. All ducts should be installed in accordance with SMACNA guidelines. The outlet end of the terminal is designed for use with slip and drive duct connections. A rectangular duct the size of the terminal outlet should be attached.

Operating Temperature Range

The operating temperature range of the product covered by this IOM is between 20 – 125°F (-7 – 52°C)

Field Wiring

All field wiring must comply with NEC and local codes. Electrical, control, and piping diagrams can be found on labels affixed to the exterior/interior of the control enclosure box. All Nailor electric heaters are staged per specifications. The installing electrician should rotate the incoming electric service by phase to help balance the building electric load.



IMPORTANT: Electric re-heat units ordered with SCR or SSR, route field wiring near bottom of control box. Do not place directly behind SCR or SSR.

Fuse size designates the size of the internal fuse if it is supplied. Maximum Overcurrent Protection (MOP) designates the largest breaker or fuse in the electrical service panel that can be used to protect the unit.

Control Start-up and Operation

Your local Nailor Representative can provide detailed information about start-up and operating procedures for Nailor's digital, analog, and pneumatic controls. For specific information on controls provided by other manufacturers, contact the specific manufacturer's local or national office. This applies whether the controls were factory or field mounted.



Note: Digital controllers may use specific communication addresses based on Building Management Systems Architecture and original engineering drawings. Installing the terminal in a location other than that noted on the label may result in excessive start-up labor.

Labels

Single duct terminals units are shipped from the factory with the following information labels.

1) Sample Nameplate Label

– affixed to the air terminal casing beside the control mounting panel. Shows tagging information, serial-model number, size, cfm, voltage, amps, MOP, etc.



Single Duct Terminal Unit
(Unité Terminale @ Ventilateur Intégré)

(Unité Terminale @ Ventilateur Intégré)

Date (Date) :	24-Jul-2012	Serial No. (No. De Série) :	383689-158.01
Model (Modèle) :	D30RE	Tag No. (No. D'étiquette) :	LVL 2 ADMIN-PALLET VIII-7-29
Unit Size-Inlet Size (Diamètre D'Entrée) :	04-04	Voltage (Voltage) :	277
Control Voltage (Voltage De Contrôle) :	24	Phase (Phase) :	1
Control Sequence (Séquence De Contrôle) :	DFK	Stages (Étapes) :	1
Volt Amp (Volt-Ampère) :	50	HZ (HZ) :	
		Hot Water Coil Rows (Nombre De Rangées Serpentin Eau Chaud) :	

	KW/HP			Amps (Ampères)			Ampacity (Ampacité)			Max. Overcurrent Protection (Resistance Des Fusible Max.)		Internal Fuse Size (If Supplied)
	Total (Totale)	Each Cir. (Chaque Circuit)	Each Stg. (Chaque Étape)	Total (Totale)	Each Cir. (Chaque Circuit)	Each Stg. (Chaque Étape)	Total (Totale)	Each Cir. (Chaque Circuit)	Each Stg. (Chaque Étape)	Total (Totale)	Each Cir. (Chaque Circuit)	
Heater (Chauffage)	1	1	1.00	3.61	3.61	3.61	4.51	4.51	4.51	15	15	15

Each Element Rated @ 1 KW @ 277 VAC. AWG. Min Wire Size (Min Diamètre De Fil) 14
 (Chaque Element Classifier A) Min. Heating CFM (Min. PCM) : 70.00

Use wire suitable for at least 75 °C, L1 is color coded black, L2 is blue, L3 is red, Control wires coded as marked, Use copper conductors only.

Utiliser un fil métallique qui convient au moins 75 °C, L1 est colore noire, L2 est bleu, L3 est rouge, Les fils de contrôle son identifiée comme marque, Utilise des conducteurs de cuivre seulement.

Primary CFM (Max/Min) : <u>80 / 60</u> <i>Primaire PCM (Max.Min) :</i>	Primary L/S (Max/Min) : <u>38 / 28</u> <i>Primaire L/S (Max.Min) :</i>
Auxiliary CFM : <u>70</u> <i>Auxiliaires PCM :</i>	Auxiliary L/S : <u>33</u> <i>Auxiliaires L/S :</i>

2) Airflow Direction Label

– affixed to the inlet collar (Supply Units) or to the Flow sensor (Exhaust Units).

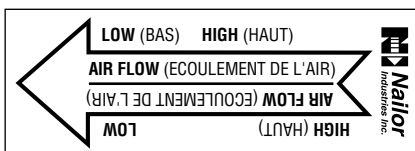

3) Sample Calibration Label

– affixed near the control mounting panel. Shows airflow calibration data.

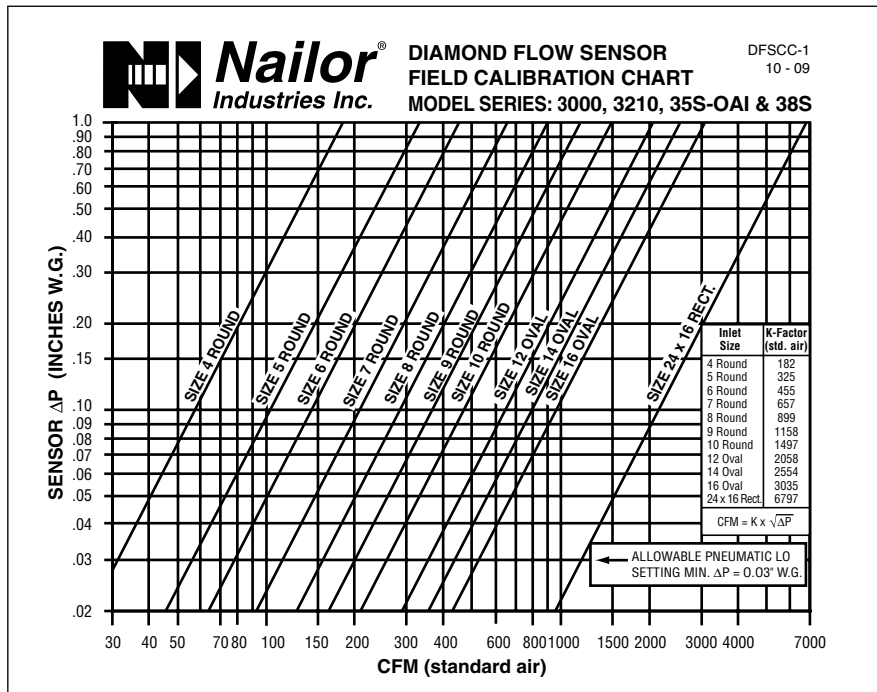

Replacement Parts

Primary Damper Valve

	Part Number
Size 4", 5", 6"	VB3-231
Size 7", 8"	VB3-233
Size 9", 10"	VB3-234
Size 12"	VB3-235
Size 14"	VB3-236
Size 16"	VB3-237
Size 24"x16"	VB3-238

Pneumatic FR Tubing (1/4" O.D.)

Black	VB3-066
Blue stripe	VB3-068
Red stripe	VB3-067

Tee for Sensor Tap

Barbed, 1/8"	VB3-058
--------------	---------

Diamond Flow Sensor

Inlet Size		Part Number
4"	3/16" O.D. tube	V1104
5"	3/16" O.D. tube	V1105
6"	3/16" O.D. tube	V1106
7"	3/16" O.D. tube	V1107
8"	3/16" O.D. tube	V1108
9"	3/16" O.D. tube	V1109
10"	3/16" O.D. tube	V1110
12"	3/16" O.D. tube	V1112
14"	3/16" O.D. tube	V1114
16"	3/16" O.D. tube	V1116
24"x 16"	3/16" O.D. tube	V1124

Control Components

Analog - See Analog Operation Manual (IOM-AECVAV)

Cap for Sensor Tee

Rubber, for 1/8" Tee	VB3-059
----------------------	---------

Recommended Maintenance

Single Duct Terminal Units supplied with stainless steel construction are supplied with Celcon® bearings as standard. Bronze oil impregnated bearings and 316 stainless steel bearings are optional for certain applications. It is recommended that those units equipped with 316 stainless steel bearings be lubricated periodically as required by the application and environment.

A Silicone based lubricant such as DuPont™ Pure Silicone Lubricant with KRYTOX® PTFE or equivalent should be applied to the shaft between the shaft and the bearing surface to prevent excessive wear. This can be done without removal of the shaft by pushing or pulling the shaft in one direction while using a spray applicator tube to inject lubricant into the small gap formed on the opposite side.

Dimensions are in inches (mm).



Houston, Texas
Tel: 281-590-1172
Fax: 281-590-3086

Las Vegas, Nevada
Tel: 702-648-5400
Fax: 702-638-0400

Toronto, Canada
Tel: 416-744-3300
Fax: 416-744-3360

Calgary, Canada
Tel: 403-279-8619
Fax: 403-279-5035